

1. Product Characteristics:

1.1 General Description

Model DTS090500UT-P5P-SZ is a universal switching-mode power supply, operating at input voltage 90VAC to 264VAC and output voltage of 9VDC with 5.0A DC load

1.2 Electric Characteristics

1.2.1 Input

NO	ITEM	SPECIFICATION
1	Rated input Voltage	AC100V-240V
	Vibration input Voltage Range	AC90V-264V
2	Frequency Rated	50-60Hz
	Frequency Vibration	47-63Hz
3	Input Rated Current	1.2A RMS Max
	Inrush Current	30A Max .at 115vac cool start
		50A Max. at 230vac cool start
4	Leakage current	3.5mA
5	Efficiency	70% Min



All information contained herein applies only to the above listed part number. Other versions of this part number with electrical or mechanical variations are available. Contact CUI Inc. for further assistance. 9615 SW Allen Blvd., Ste. 103, Beaverton OR 97005
800-275-4899 • 503-643-4899 • Fax: 503-643-6129 • www.cui.com

1.2.2 Output:

No	ITEM	SPECIFICATION
1	*output Voltage	+9VDC
2	*output max. current	5.0A
3	output min. Current	0A
4	Line regulation	±1%
5	Load regulation	±5%
6	Over voltage protection	11.4V to 12.6V (output shut down)
7	Short circuit protection	Output shut down and auto restart
8	Ripple Voltage (L.F.)	100mV (p-p) (100V-240VAC Input)

1.2.3 HI-POT SPECIFICATION

Input to output : 1500VAC OR 2121VDC 10mA 1 minute.

1.2.4 Insulation resistance:

Input to output: 500vdc to test the input to output resistance not be less

100M ohm

1.2.5 Safety approved: UL, CUL, ITS/GS, CE

1.2.6 EMI standard : meet FCC class B , CE ,VCCI – II



All information contained herein applies only to the above listed part number. Other versions of this part number with electrical or mechanical variations are available. Contact CUI Inc. for further assistance. 9615 SW Allen Blvd., Ste. 103, Beaverton OR 97005
800-275-4899 • 503-643-4899 • Fax: 503-643-6129 • www.cui.com

1.3 Mechanical Characteristics:

1.3.1 AC Plug : INLET IEC320 3PIN Type.

1.3.2 DC cord:

(1) Bending test: Life 1000 times 100% guarantee. Swings 120 from

Left to right loading weight 500g , 40 cycle/minute.

(2) Pull test : DC cord and plug ,weight 6kg for 1 minute.

1.3.3 Cord length and output plug: See Reference Att.4

1.3.4 Weight : 474 g

1.3.5 Case Size: 108.1X66X36.1mm

1.3.6 Normal operating temperature and humidity

1.3.7 Temperature

Operating: 0°C to 40°C



Storage: -10°C to 70°C

1.3.8 Humidity

Operating: 20% to 80%

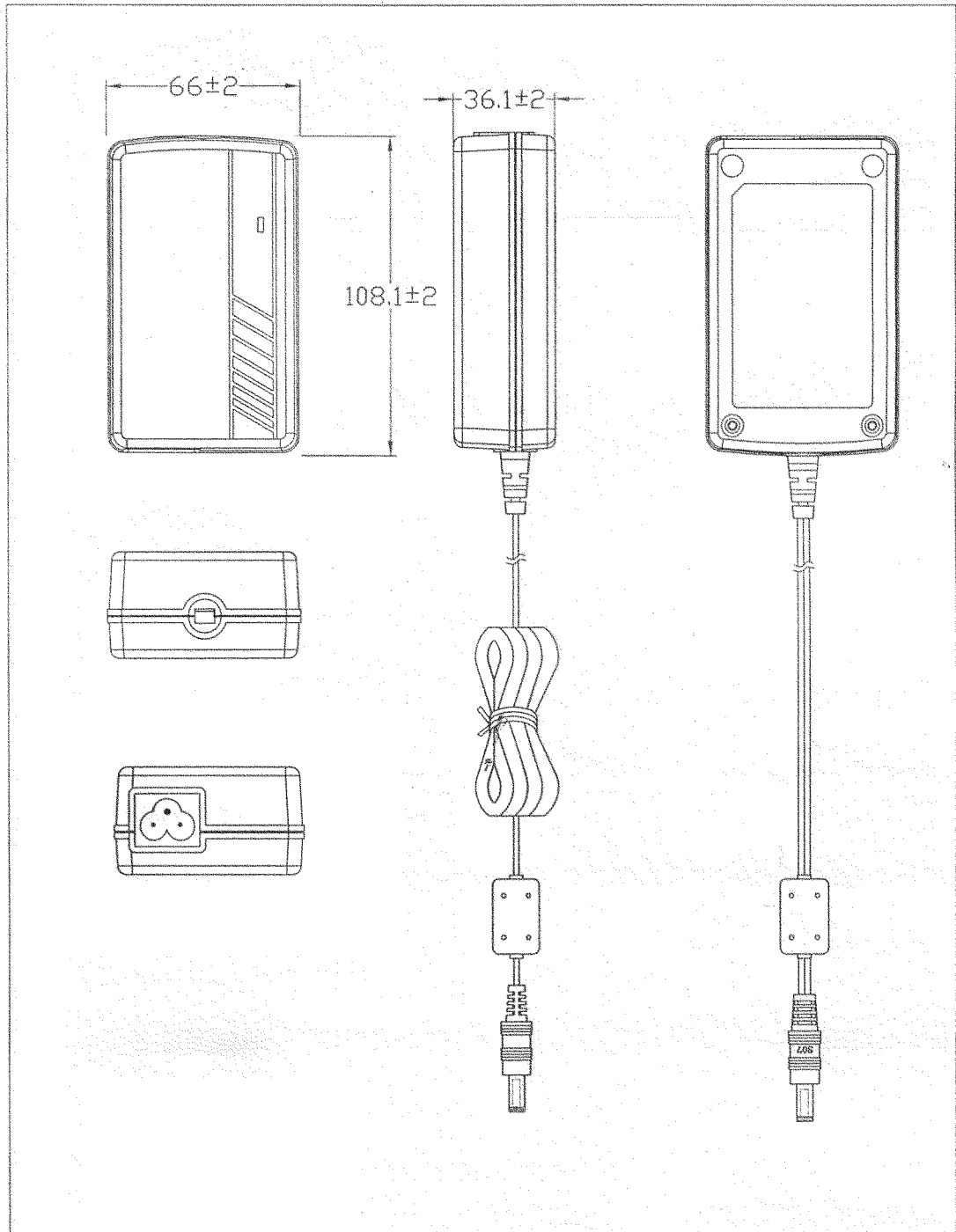
Storage: 10% to 90%



					
	mm			296525FS0	03-06-18
 CUI INC				296PS-525	01

MODEL NO:

PART NO: DTS090500UT-P5P-SZ



CUI INC

PAGE NO: 5 of 5

UNIT: mm

DATE: 7/18/03

All information contained herein applies only to the above listed part number. Other versions of this part number with electrical or mechanical variations are available. Contact CUI Inc. for further assistance. 9615 SW Allen Blvd., Ste. 103, Beaverton OR 97005
800-275-4899 • 503-643-4899 • Fax: 503-643-6129 • www.cui.com

