

PART NUMBER: VHK100W

DESCRIPTION: chassis mount dc-dc converter

description

The VHK100W series of rugged DC-DC converters are designed for high reliability applications, featuring integral heat sink, over-temperature protection, over-current protection and input transient voltage protection. With an external input fuse, the converter can protect accidental input polarity reversal. The wide 4:1 input range (10-36V or 18-75V) is very useful to stabilize an input source like batteries in various discharging and charging conditions. Additionally, high efficiency, fast response, tight regulations, remote sense and remote On/Off control make these converters very useful in many industrial and communications applications.

features

- 66-100W isolated output
- Efficiency to 87%
- RoHS Compliant
- 4:1 input range
- Regulated output
- Continuous short circuit protection
- Metal enclosure with integrated heatsink
- Rugged design
- Over-temperature shutdown

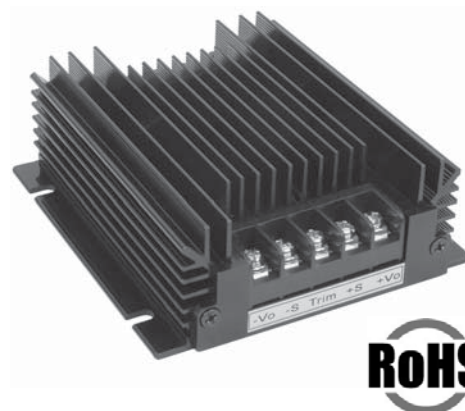
MODEL

MODEL	input voltage		output voltage (V dc)	output current ¹ (A)	input current		efficiency typ. ³ (%)
	nominal (V dc)	range (V dc)			no load ² (mA)	full load ² (mA)	
VHK100W-Q24-S3R3	24	9.0~36.0	3.3	20	35	3438	80
VHK100W-Q24-S5	24	9.0~36.0	5	20	35	5081	82
VHK100W-Q24-S12	24	9.0~36.0	12	8.3	35	4940	84
VHK100W-Q24-S15	24	9.0~36.0	15	6.7	35	4898	85.5
VHK100W-Q24-S24	24	9.0~36.0	24	4.17	35	4905	85
VHK100W-Q24-S28	24	9.0~36.0	28	3.57	35	4151	86
VHK100W-Q24-S48	24	9.0~36.0	48	2.08	35	4952	84
VHK100W-Q48-S3R3	48	18.0~75.0	3.3	20	50	1741	79
VHK100W-Q48-S5	48	18.0~75.0	5	20	50	2465	84.5
VHK100W-Q48-S12	48	18.0~75.0	12	8.3	50	2427	85.5
VHK100W-Q48-S15	48	18.0~75.0	15	6.7	50	2421	86.5
VHK100W-Q48-S24	48	18.0~75.0	24	4.17	50	2397	87
VHK100W-Q48-S28	48	18.0~75.0	28	3.57	50	4151	86
VHK100W-Q48-S48	48	18.0~75.0	48	2.08	50	2447	85

- notes:
1. see output derating curves (page 4)
 2. input currents are measured at nominal input voltage
 3. efficiency is measured at nominal line, full load

INPUT

parameter	conditions/description	min	nom	max	units
input voltage range		9	24	36	V dc
		18	48	75	V dc
under voltage lockout	24 Vin power up		8.8		V dc
	24 Vin power down		8		V dc
	48 Vin power up		17		V dc
	48 Vin power down		16		V dc
remote on/off control ⁴	section 13 in the application notes				
input filter	PI type				

- notes:
4. add suffix "N" to the model number for negative logic on/off control

*V-Infinity reserves the right to make changes to its products or to discontinue any product or service without notice, and to advise customers to verify the most up-to-date product information before placing orders. V-Infinity assumes no liability or responsibility for customer's applications using V-Infinity products other than repair or replacing (at V-I's option) V-Infinity products not meeting V-I's published specifications. Nothing will be covered outside of standard product warranty.

PART NUMBER: VHK100W**DESCRIPTION:** chassis mount dc-dc converter**OUTPUT**

parameter	conditions/description	min	nom	max	units
voltage accuracy				±1.5	%
transient response	25% step load change			500	μ sec
external trim adj. range				±10	%
ripple & noise (20MHz BW)	3.3V, 5V			40	mV RMS
				100	mV p-p
	12V& 15V			60	mV RMS
				150	mV p-p
	24V			100	mV RMS
				240	mV p-p
	28V			100	mV RMS
			280	mV p-p	
	48V			200	mV RMS
				480	mV p-p
temperature coefficient			±0.03		%/°C
short circuit protection	continuous				
line regulation ⁵				±0.2	%
load regulation ⁶				±1	%
over voltage protection trip range, % Vo nom.		115		140	%
over current protection	% nominal output current	110		140	%

GENERAL SPECIFICATIONS

parameter	conditions/description	min	nom	max	units
switching frequency			250		KHz
operating ambient temp. ⁷	derated from 50 to 85°C	-40		85	°C
storage temperature		-55		105	°C
thermal shutdown case temp.			90		°C
case material	aluminum				

ISOLATION SPECIFICATIONS

parameter	conditions/description	min	nom	max	units
isolation voltage	input/output	1500			V dc
	input/case	1500			V dc
	output/case	1500			V dc
isolation resistance		100			MΩ

notes:
 5. measured from high line to low line at full load
 6. measured from full load to zero load at nominal input
 7. see output derating curves (page 4)

*V-Infinity reserves the right to make changes to its products or to discontinue any product or service without notice, and to advise customers to verify the most up-to-date product information before placing orders. V-Infinity assumes no liability or responsibility for customer's applications using V-Infinity products other than repair or replacing (at V-I's option) V-Infinity products not meeting V-I's published specifications. Nothing will be covered outside of standard product warranty.

REV.	DESCRIPTION	DATE
A	NEW DRAWING	4/22/2008
B	dimension updates	8/27/2008

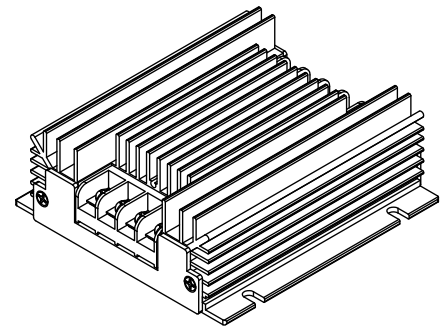
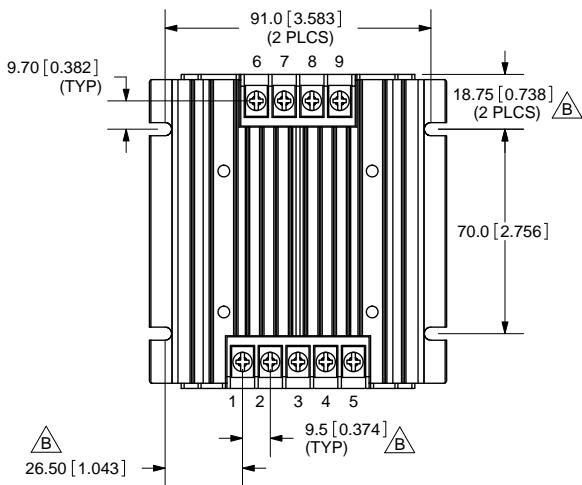
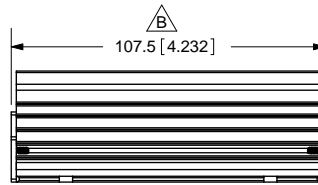
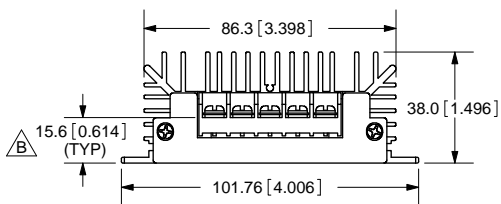

TOLERANCE:
±0.3mm UNLESS OTHERWISE
SPECIFIED



*DIN rail mounting kit available (part# VHK-DIN)

Terminal #	Description
1	- V out
2	- S
3	Trim
4	+ S
5	+ V out
6	Case
7	Remote
8	- V in
9	+ V in



20050 SW 112th Ave.
Tualatin, OR 97062
Phone: 503-612-2300
800-275-4899
Fax: 503-612-2383
Website: www.cui.com

TITLE: VHK	REV: B
PART NO. VHKXXW Series	UNITS: MM [INCHES]
DRAWN BY: ZRJ	APPROVED BY:
	SCALE: 1:2

PC FILE NAME:
VHKXXW Series

COPYRIGHT 2008 BY CUI INC.

Material Aluminum/Steel

PART NUMBER: VHK100W

DESCRIPTION: chassis mount dc-dc converter

APPLICATION NOTES

1. OUTPUT DE-RATING

The operating ambient temperature range for VHK100W is $-40 \sim +85^{\circ}\text{C}$, with the actual output power subject to the following de-rating curves at free-air convection and at forced air conditions. To ensure long-term reliability, it is important to ensure proper cooling at the worst operating conditions. Please note the derating curves may improve if the converter is mounted on a metal surface to allow heat conduction.

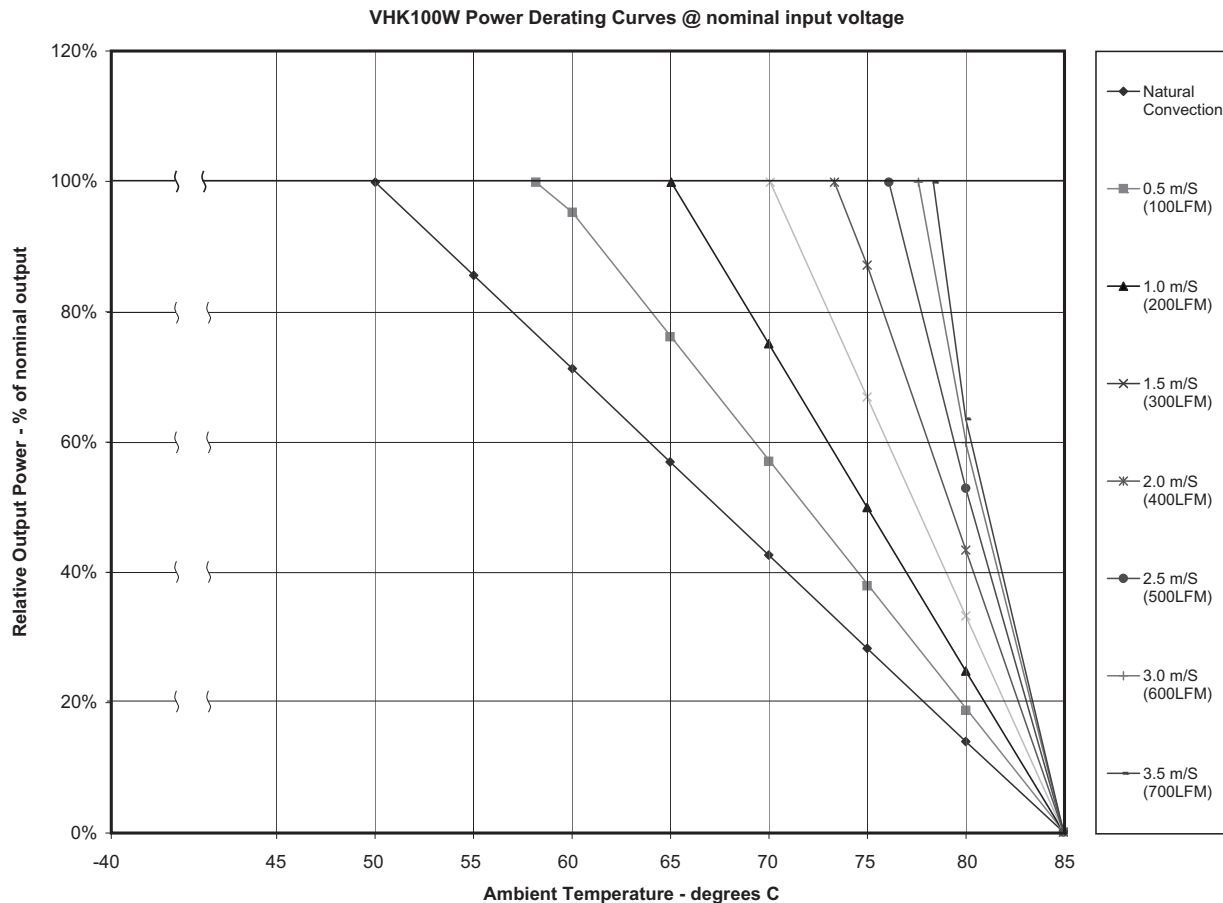

FIGURE 1. OUTPUT DERATING

2. INPUT VOLTAGE RANGE

It is important to ensure the input voltage measured at the converter input pins is within the range for that converter. Make sure wire losses and voltage ripples are accounted for. One possible problem is driving the converter with a linear unregulated power supply. For example, if the average voltage measured by a DMM is 9V, with a voltage ripple of 3Vpp, the actual input can swing from 7.5V to 10.5V. This will be outside the specified input range of 10-36V and the converter may not function properly. On the other end, make sure the actual input voltage does not exceed the highest voltage of 36V or 75V.

3. LEAD WIRES

Make sure the input and output wires are of adequate AWG size to minimize voltage drop, and ensure the voltage across the input terminals is above the converter's rated minimum voltage at all times. It is recommended to have the wire pairs twisted, respectively for the input pair and the output pair, so as to minimize noise pickup.

PART NUMBER: VHK100W

DESCRIPTION: chassis mount dc-dc converter

4. INPUT CURRENT

The input voltage source must be able to provide enough current to the converter, otherwise it may not start up or operate properly. A typical symptom is not starting or unusually low output voltage. In general, it is recommended to be able to provide at least:

$I_{peak} = 150\% \cdot P_{out} / (\eta \cdot V_{min})$ where P_{out} is the maximum output power, V_{min} is the minimum input voltage and η is the converter's efficiency. As an example, for VHK100W-Q24-S12 to operate with 9~36V input, 100W output and an efficiency of 85%, the minimum source current is recommended to be: **$I_{peak} = 150\% \cdot 100 / (85\% \cdot 9) = 19.61A$** .

5. INPUT FUSE

To limit the input current and to facilitate input reversal protection and input OVP protection, a fast-acting input fuse is recommended for the input line. The fuse rating will depend on the input range and should allow for the maximum current at the lowest input voltage, as shown in this equation: **$I_{peak} = 150\% \cdot P_{out} / (\eta \cdot V_{min})$** .

In the previous example of VHK100W-Q24-S12, the peak input current at 9V was calculated to be 19.61A. A 20A fuse may be suitable for this application. Make sure the fuse voltage rating is higher than the maximum input voltage.

6. INPUT OVP

It is important to ensure the input voltage does not exceed the maximum rated input voltage for that model. To suppress voltage transients of short durations, the converter includes a transient voltage suppression device (TVS) at the input. The built-in TVS has a rated breakdown voltage of 39V for the VHK100W-Q24-XX models and 82V for the VHK100W-Q48 models. With small transients of short-durations, the TVS will limit the input voltage without interrupting the converters operations. For large transients, the TVS may conduct a large amount of current that may trip the input fuse. Without the input fuse, the converter may suffer permanent damages. When the fuse is open, replace it with one of same type and ratings.

7. INPUT REVERSAL PROTECTION

If the input voltage is reversed for any reason, the built-in protection circuits in the converter will limit the reverse voltage to one diode drop which is no more than 1V. With an external input fuse connected, the fuse will open and thus remove power from the converter. Check the wiring and make corrections as needed. The input fuse will need to be replaced. Make sure the new fuse is of the same type and rating. Without the input fuse, the converter may suffer permanent damages in a reversal situation.

8. REMOTE SENSE

The converter provides regulated outputs at the output terminals. When there is a large current and/or the output cable is of some length, the voltage at the end of the output cable may be noticeably lower than at the terminals. The converter can compensate up to 0.5V of voltage drop through remote sense terminals. To ensure accurate regulation, run two separate wires (twisted) from the desired regulation points to the remote sense terminals, as shown below. Even if the load current is low, still connect +Vo to +S and -Vo to -S.

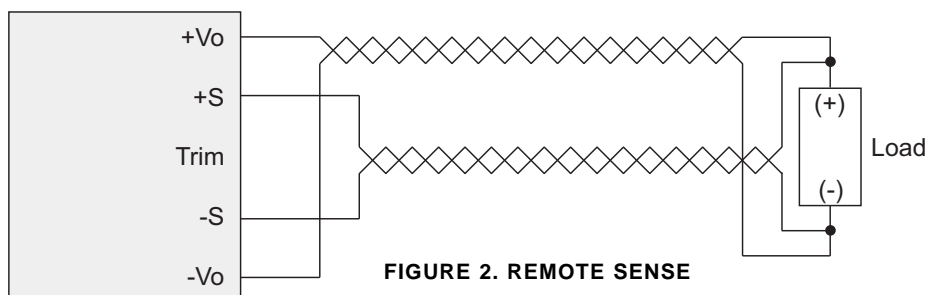

PART NUMBER: VHK100W

DESCRIPTION: chassis mount dc-dc converter

9. OUTPUT TRIMMING (OPTIONAL)

The output voltages are preset to nominal values as indicated by the models table at the factory. If desired, the output voltage may optionally be trimmed to a different value (+/- 10%) with external resistors and/or potentiometer as shown below.

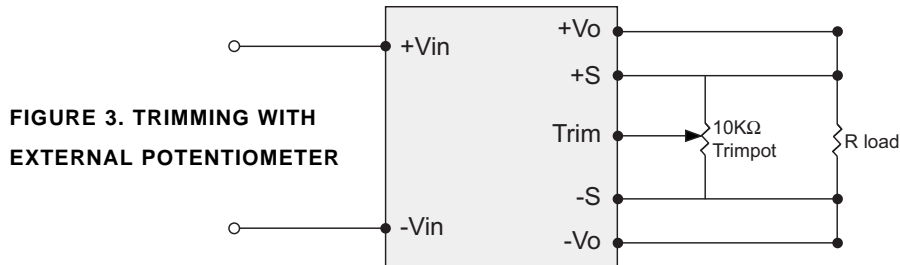
FIGURE 3. TRIMMING WITH EXTERNAL POTENTIOMETER

To trim the output voltage with fixed resistors, the output voltage can be calculated as follows.

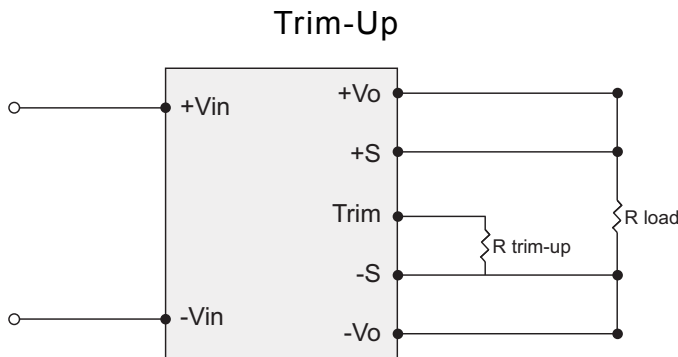
FIGURE 4: TRIM-UP VOLTAGE SETUP

The value of $R_{trim-up}$ is defined as:

$$R_{trim-up} = \frac{R1 - R2 \times (\Delta V)}{\Delta V} \text{ (K}\Omega\text{)}$$

Where: $R_{trim-up}$ is the external resistor in $K\Omega$. $V_{o,nom}$ is the nominal output voltage. V_o is the desired output voltage. R_1 , R_2 , R_3 , V_r , and V_f are internal to the unit and are defined in Table 1. For example, to trim-up the output voltage of 5.0V module (VHK100W-Q48-S5) by 8% to 5.4V, $R_{trim-up}$ is calculated

as follows:

$$V_o - V_{o,nom} = 5.4 - 5.0 = 0.4 \text{ V}$$

$$R1 = 5.8 \text{ K}\Omega$$

$$R2 = 3.3 \text{ K}\Omega$$

$$R_{trim-up} = \frac{5.8 - 3.3 \times 0.4}{0.4} = 11.2 \text{ (K}\Omega\text{)}$$

Output Voltage(V)	R1(KΩ)	R2(KΩ)
3.3V	3.168	7.2
5V	5.8	8.2
12V	19.656	13.304
15V	25.474	14.76
24V	42.33	16.67
28V	48.78	5.954
48V	74.25	13.3

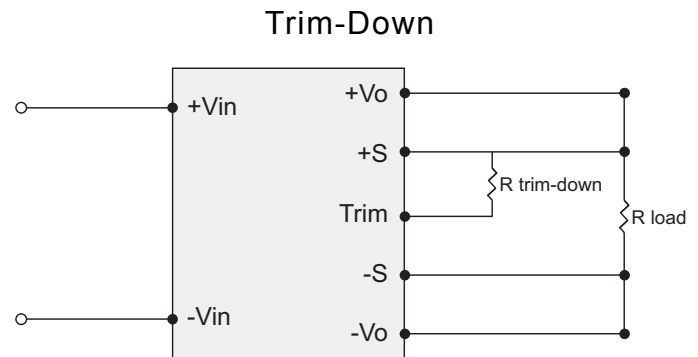
Table 1

FIGURE 5: TRIM-DOWN VOLTAGE SETUP

The value of $R_{trim-down}$ is defined as:

$$R_{trim-down} = \frac{R1 - R2 \times (\Delta V)}{\Delta V} \text{ (K}\Omega\text{)}$$

Where: $R_{trim-down}$ is the external resistor in $K\Omega$. $V_{o,nom}$ is the nominal output voltage. V_o is the desired output voltage. R_1 , R_2 , and V_r are internal to the unit and are defined in

Table 1. For example, to trim-down the output voltage of 5.0V module (VHK100W-Q48-S5) by 8% to 4.6V, $R_{trim-down}$ is calculated

as follows:

$$V_{o,nom} - V_o = 5.0 - 4.6 = 0.4 \text{ V}$$

$$R1 = 5.8 \text{ K}\Omega$$

$$R2 = 5.32 \text{ K}\Omega$$

$$R_{trim-down} = \frac{5.8 - 5.32 \times 0.4}{0.4} = 9.18 \text{ (K}\Omega\text{)}$$

Output Voltage(V)	R1(KΩ)	R2(KΩ)
3.3V	6.18	15
5V	5.8	10.52
12V	86.45	60.1
15V	150	94
24V	430	120
28V	608.6	173.7
48V	1638	306

Table 2

PART NUMBER: VHK100W

DESCRIPTION: chassis mount dc-dc converter

10. OUTPUT OCP AND SHORT-CIRCUIT PROTECTION

Output overload and short circuit conditional will cause the output voltage to decline or shutdown altogether. If the case temperature is not over 105°C, the output recovers automatically when the short or OCP conditions are removed. In the case of slight overloading, the output voltage may not shut down, but the converter may build up heat over time, causing over-temperature shutdown.

11. OVER-TEMPERATURE PROTECTION

When the case temperature reaches about 105°C, the converter's built-in protection circuit will shut down the output. When the temperature is reduced enough to a safe operating level, the converter will recover to normal operations automatically.

12. OUTPUT OVP

In case the output voltage exceeds the OVP threshold, the converter shuts down.

13. OUTPUT PARALLEL CONNECTIONS

The converter is not designed for load share on the output. One may be inclined to use this circuit to force current sharing by trimming the output voltages for each converter. However, this circuit may not reliably or accurately divide the load current, as the device characteristics of the converters or the diodes may not be balanced over a range of operating conditions. We generally do not recommend this circuit to increase power output over a single converter. Instead, we recommend this setup for redundancy only, having one converter as a backup in case of a failure. Make sure the OR-ing diodes can handle the voltage and full load current.

**FIGURE 6. OUTPUT
PARALLEL CONNECTIONS**

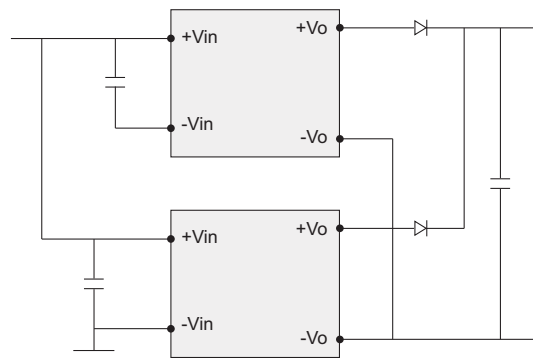

PART NUMBER: VHK100W

DESCRIPTION: chassis mount dc-dc converter

14. OUTPUT SERIES CONNECTIONS

Two or more converters can be connected in series to obtain a higher output voltage. To prevent output reverse biasing each other in case of a short, add a Schottky diode on each output in reverse polarity, as shown in the diagram. In the event of a short, the converters will forward-bias the diodes and the output reversal will be limited to one diode drop (about 0.5V) only, so as not to damage the converters. The forward current will cause each converter to go into short-circuit protection. For proper diode selection, make sure that: 1) the diodes voltage rating is higher than each converter output; 2) the rated diode current can carry the short-circuit current; 3) the diodes do not overheat before the short is removed.

FIGURE 7. OUTPUT SERIES CONNECTIONS

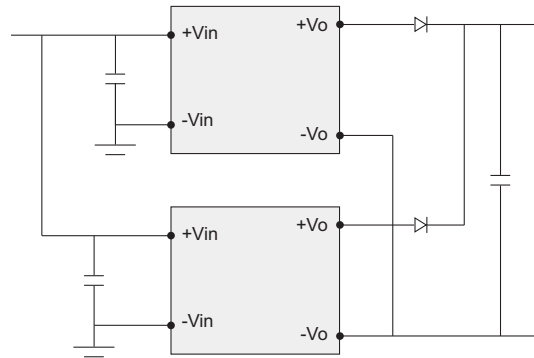

15. REMOTE OUTPUT ON/OFF CONTROL

The converter output can be enabled or disabled through the On/Off pin. The control logic is shown in this table. A common control circuit is shown below. The standard version defaults to positive logic. For negative logic, indicate the selection when ordering.

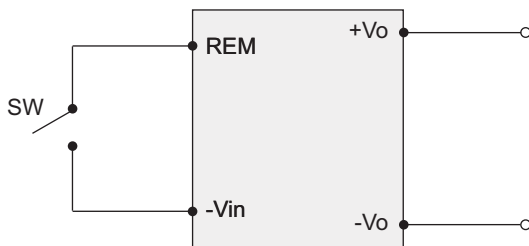

FIGURE 8. REMOTE ON/OFF CONTROL

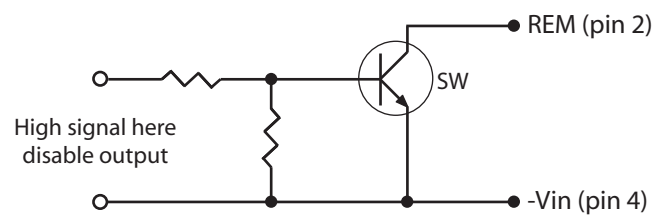

FIGURE 9. REMOTE ON/OFF CONTROL WITH TRANSISTOR SWITCH

Logic Table	Negative logic	Positive logic
SW Closed ($V_{REM} < 1.2\text{ V}$)	Output on	Output off
SW Open ($V_{REM} > 3.5\sim 75\text{ V}$ or Open Circuit)	Output off	Output on

16. ISOLATION

The input and output of the converter are electrically isolated. If needed, an output terminal can be connected to an input terminal, resulting in the converter non-isolated.

PART NUMBER: VHK100W

DESCRIPTION: chassis mount dc-dc converter

17. INPUT FILTERING AND EMI INTERFERENCE

The VHK100W converters have input capacitors that control input current ripple and the associated EMI interference. However, it has not been tested to a formal standard for conducted emissions. Additional filtering may be needed to ensure compliance to an EMI standard. Refer to FIGURE 10.1 and 10.2 for reference circuits.

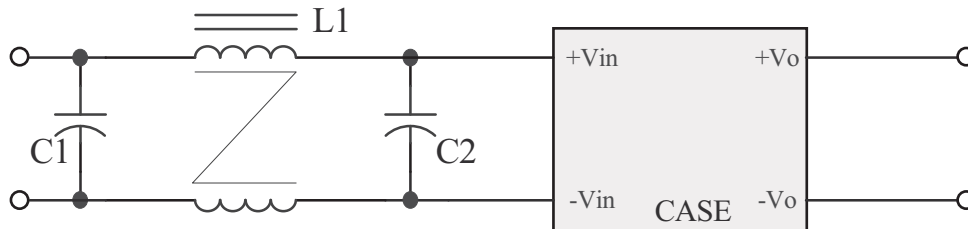
FIGURE 10.1. EMI FILTER FOR EN55022 CLASS A

EN55022 class A	C1	C2	L1
All 24 V input models	47 μ F/50 V	47 μ F/50 V	3.4 μ H
VHK100W-Q48-S3R3	47 μ F/100 V	NC	3.4 μ H
VHK100W-Q48-S15	47 μ F/100 V	NC	3.4 μ H
All other 48 V input models	47 μ F/100 V	47 μ F/100 V	3.4 μ H

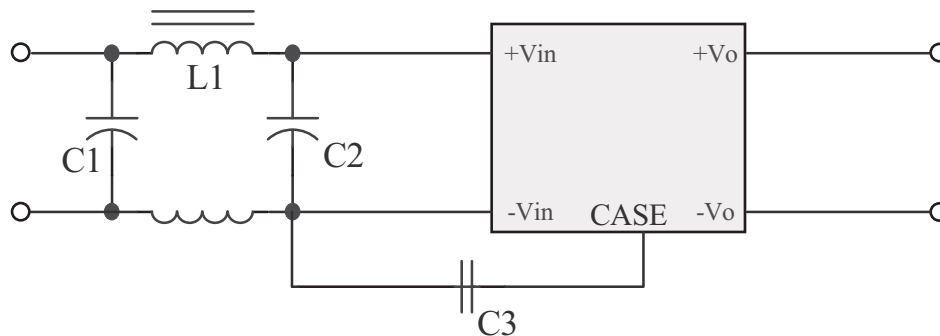
FIGURE 10.2. EMI FILTER FOR EN55022 CLASS B

EN55022 class B	C1	C2	C3	L1
VHK100W-Q24-S48	220 μ F/50 V	220 μ F/50 V	4700 pF/2 KV	3.4 μ H
All other 24 V input models	220 μ F/50 V	220 μ F/50 V	NC	3.4 μ H
VHK100W-Q48-S48	47 μ F/100 V	47 μ F/100 V	4700 pF/2 KV	3.4 μ H
All other 48 V input models	47 μ F/100 V	47 μ F/100 V	NC	3.4 μ H

note: The recommended components are a starting point but not guaranteed for meeting these EMI requirements. More or less filtering may be required for a specific application or to meet other EMI standards, e.g.MIL-STD-461

PART NUMBER: VHK100W

DESCRIPTION: chassis mount dc-dc converter

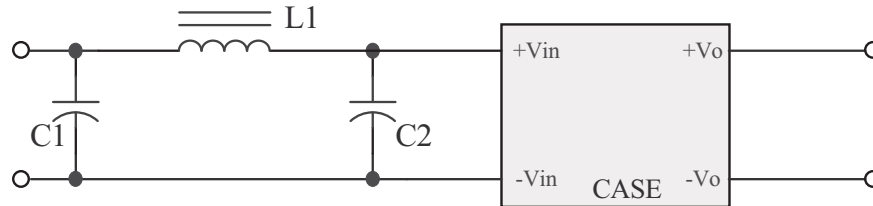
FIGURE 10.3. EMI FILTER FOR VHK100W-XXX-S28

1. Conduction EN55022 class A

Model No.	C2	C3	L1
VHK100W-Q24-S28	47uF/50V KY	47uF/50V KY	3.4uH
VHK100W-Q48-S28	47uF/100V KY	47uF/100V KY	3.4uH

2. Conduction EN55022 class B

Model No.	C1	C2	L1
VHK100W-Q24-S28	220uF/50V KY	220uF/50V KY	3.4uH
VHK100W-Q48-S28	47uF/100V KY	47uF/100V KY	3.4uH

note: The recommended components are a starting point but not guaranteed for meeting these EMI requirements. More or less filtering may be required for a specific application or to meet other EMI standards, e.g.MIL-STD-461

18. OUTPUT FILTERING

The converter has built-in capacitors at the output to control ripple and noise. If desired, additional output capacitance can be introduced at the input to the powered equipment. Recommended starting point: one 10 μ F tantalum and one 1 μ F ceramic capacitor in parallel at the output.

19. OUTPUT NOISE MEASUREMENT SCHEMATIC

For proper output ripple and noise measurement, connect a 10 μ F tantalum and a 1 μ F ceramic capacitor across the output. Set the scope bandwidth to 20MHz. Probe directly off of one of the capacitors, using a small ground clip to minimize measurement error.

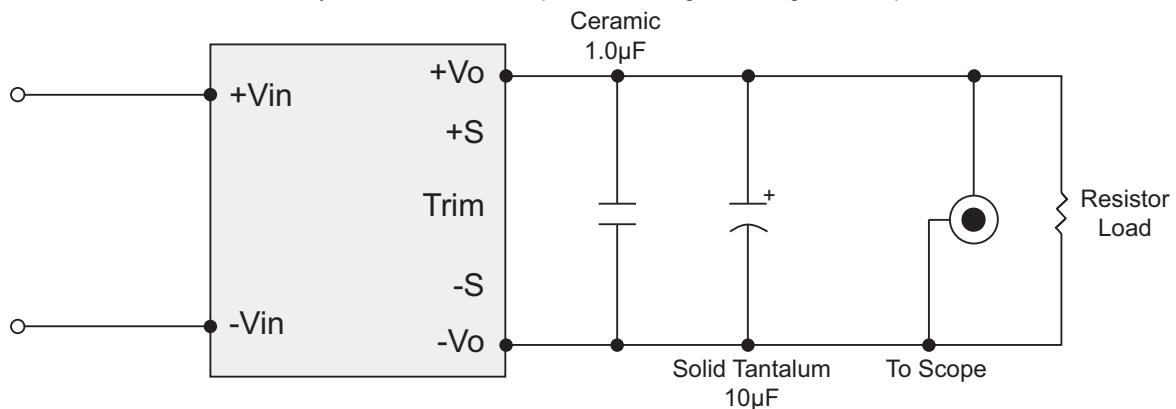
FIGURE 11. OUTPUT NOISE MEASUREMENT CIRCUIT