

Programmable Power Supplies





Innovating Reliable Power



Contents	Page
Genesys™	6
Software / Features	7
Product range / how to order	8
Front / rear panel description	10
Specifications 750 / 1500 W	14
Specifications 2400 W	20
Specifications 3.3 / 5 kW	26
Accessories	33
Specifications 10 / 15 kW	34
Configuration	40
Programming options	41
Outline drawings	42
Zero-up	46
Product range	46
Front / rear panel description	47
How to order	47
Specifications	48
Configuration	54
Programming options	55
Rack mounted ATE and OEM	55
GP485A	56
Outline drawings	57
Options	58
Accessories	59



*Intelligent Power
for Science
and Industry*



Many applications require more than a fixed voltage. Today's test systems and industrial processes require stable and accurate control of output voltage and current during operation with the facility to monitor these parameters.

Genesys™ and ZUP are designed to fulfil these requirements by offering RS-232/RS-485 and analogue control and monitoring interfaces built in as standard. Further options for Genesys™ include LAN (**LXI** compliant) and GPIB (SCPI compliant).

Various software drivers, such as IVI-COM and Labview, and tools are downloadable from our website to enable easy integration with industry standard software control packages.

Applications

Genesys™ and ZUP can provide the best solution for programmable power in many applications by offering comprehensive control and monitoring features that are intuitive and easy to use and not overly complex.

Automotive

- Component burn-in
- Fuel cell
- Lamp testing
- Component development
- Battery simulation

Semiconductor

- Burn-in
- Deposition
- Ion implantation
- Component lead electroplating
- MBE systems
- MOCVD for LED manufacture
- Solar cell manufacture

Medical

- X-Ray
- Oncology
- MRI
- Magnets
- Gradient amplifiers

Aerospace & Defence

- RF communication
- Satellite test systems
- Materials research
- ATE systems

Diode Laser

- Medical
- Marking
- Cutting
- Welding

Test & Measurement

- Large ATE systems
- Component test
- Analytical instrument
- Module and component burn-in
- Solar inverter testing

Other Industrial

- Water purification
- Plating and etching
- Capacitor forming
- Shipborne DC power



The Genesys™ family of programmable power supplies sets a new standard for flexible, reliable, AC/DC power systems in OEM, Industrial and Laboratory applications.

Features

- **High Power Density**
 - 750 / 1500 / **NEW** 2400 W in 1 U – 3.3 / 5 kW in 2 U
 - 750 W in 9.5" 1 U – 10 / 15 kW in 3 U
- **Wide Range of popular worldwide AC inputs**
 - 1-phase wide range (85 – 265 V AC)
 - 1-phase (230 V AC)
 - 3-phase (208 V AC, 400 V AC, 480 V AC) model dependent
- **Active/passive Power Factor Correction** (Single-Phase & Three-Phase AC Input)
- **Output Voltage up to 600 V, Current up to 1000 A**
- **Built-in RS-232 / RS-485 Interface Standard**
- **Global Commands for Serial RS-232 / RS-485 Interface**
- **Auto-Re-Start / Safe-Start: user-selectable**
- **Last-Setting Memory; Front panel lockout**
- **High Resolution 16 bit ADCs & DACs**
- **Low Ripple & Noise**
- **Front Panel Lock selectable from Front Panel or Software**
- **Reliable Encoders for Voltage and Current Adjustment**
- **Constant Voltage / Constant Current auto-crossover**

- **Parallel Operation with Active Current Sharing; up to four identical units**
- **Advanced Parallel Master/Slave**
 - Total Current is programmed and measured via the master
- **Independent Remote ON/OFF and Remote Enable / Disable**
- **External Analog Programming and Monitoring** (user-selectable 0 – 5 V & 0 – 10 V)
- **Programmable foldback delay for current limit**
- **Auxiliary output 5 V/0.2 A isolated, 15 V/0.2 A nonisolated (GEN 2.4 kW only)**
- **Reliable Modular and SMT Design**
- **19" Rack Mount capability for ATE and OEM applications**
- **Optional Interfaces**
 - Isolated Analog Programming and Monitoring Interface (0 – 5 V / 0 – 10 V & 4 – 20 mA)
 - IEEE 488.2 SCPI (GPIB) Multi-Drop
 - **LXI** compliant LAN interface
- **LabView™ Genesys™ Control (Runtime Modul) and Drivers**
- **Five Years Warranty**

Worldwide Safety Agency Approvals; CE Mark for LVD and EMC Regulation



Applications

Genesys™ power supplies have been designed to meet the demands of a wide variety of applications. System Designers will appreciate new, standard, remote programming features such as Global commands. Also, new high-speed status monitoring is available for the RS-485 bus.

Test Systems using the IEEE-488 bus may achieve significant cost savings by incorporating the Optional IEEE Multi-Drop Interface for a Master and up to 30 RS-485 Multi-Drop Slaves.

Higher power systems can be configured with up to four Genesys™ units. Each Genesys™ unit can be stacked zero space between them (zero stack). Between the modules there is no additional space required.

Flexible configuration is provided by the complete Genesys™ family: 1 U 750 W Half-Rack, 1 U 750 – 2400 W, 2 U 3.3 / 5 kW, 3 U 10 / 15 kW Full-Rack. All are identical in Front Panel, Rear Panel Analog, and all Digital Interface Commands.

OEM Designers have a wide variety of Inputs and Outputs from which to select depending on application and location.

Drivers / Software for Genesys™

The Genesys™ family of programmable power supplies contain several interfaces such as RS-232/RS-485, IEEE 488.2 SCPI or LAN **LXI**, to enable from a computer-system. With Graphical programming languages like for example LabView™ the Genesys™ can easily be integrated into complex test-applications and production lines.

On the website TDK-Lambda offers free download of several drivers and runtime engines to control Genesys™. In the product section for laboratory power supplies there is a link to the software download for each laboratory power supply series.

After registration on the following website is given access to drivers and runtime engines for LabView™ and LabWindows™. Now available are the IVI-Com and IVI-C drivers for serial, IEEE and LAN.

www.us.tdk-lambda.com/hp/register.htm

The driver download is updated continuously. For special requirements, please contact your local Sales Office.

Genesys™ Control Software 3.3

This is an easy to use runtime engine for Windows to control up to two Genesys™ units via RS-232 interface. The software can easily be downloaded as a ZIP-file including documentation.

General Information

- GenesysControl is an application to control up to two Genesys™ devices via the serial line.
- GenesysControl supports all Genesys™ types (GEN and GENH) and all available firmware versions.
- GenesysControl replicates the power supply front panel features on your PC.

Computer Requirements

- A Windows PC with Win 95, 98, 98SE, ME, 2000 or XP, >200 MHz CPU, at least 32 MB RAM and 1 MB of HD space.

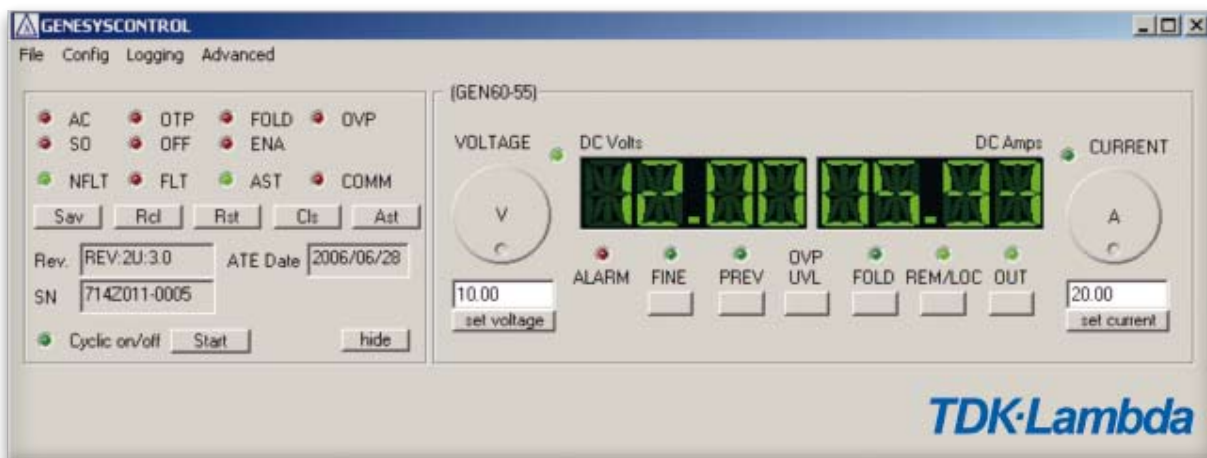

Models GENH750 W in 1 U halfrack

Model	Output Voltage V DC	Output Current (A)	Output Power (W)
GENH6-100	0~6 V	0~100 A	600 W
GENH8-90	0~8 V	0~90 A	720 W
GENH12.5-60	0~12.5 V	0~60 A	750 W
GENH20-38	0~20 V	0~38 A	760 W
GENH30-25	0~30 V	0~25 A	750 W
GENH40-19	0~40 V	0~19 A	760 W
GENH60-12.5	0~60 V	0~12.5 A	750 W
GENH80-9.5	0~80 V	0~9.5 A	760 W
GENH100-7.5	0~100 V	0~7.5 A	750 W
GENH150-5	0~150 V	0~5 A	750 W
GENH300-2.5	0~300 V	0~2.5 A	750 W
GENH600-1.3	0~600 V	0~1.3 A	780 W

Models GEN750/1500/NEW 2400 W in 1 U 19" rack

Model	Output Voltage V DC	Output Current (A)	Output Power (W)	*
GEN6-100	0 ~ 6 V	0 ~ 100 A	600 W	
GEN6-200		0 ~ 200 A	1200 W	
GEN8-90		0 ~ 90 A	720 W	
GEN8-180	0 ~ 8 V	0 ~ 180 A	1440 W	
GEN8-300		0 ~ 300 A	2400 W	
GEN10-240		0 ~ 240 A	2400 W	C
GEN12.5-60	0 ~ 12.5 V	0 ~ 60 A	750 W	
GEN12.5-120		0 ~ 120 A	1500 W	
GEN16-150		0 ~ 150 A	2400 W	B
GEN20-38	0 ~ 16 V	0 ~ 38 A	760 W	
GEN20-76		0 ~ 76 A	1520 W	
GEN20-120		0 ~ 120 A	2400 W	C
GEN30-25	0 ~ 20 V	0 ~ 25 A	750 W	
GEN30-50		0 ~ 50 A	1500 W	
GEN30-80		0 ~ 80 A	2400 W	B
GEN40-19	0 ~ 30 V	0 ~ 19 A	760 W	
GEN40-38		0 ~ 38 A	1520 W	
GEN40-60		0 ~ 60 A	2400 W	B
GEN50-30	0 ~ 50 V	0 ~ 30 A	1500 W	
GEN60-12.5	0 ~ 40 V	0 ~ 12.5 A	750 W	
GEN60-25		0 ~ 25 A	1500 W	
GEN60-40		0 ~ 40 A	2400 W	
GEN80-9.5	0 ~ 50 V	0 ~ 9.5 A	760 W	
GEN80-19		0 ~ 19 A	1520 W	
GEN80-30		0 ~ 30 A	2400 W	C
GEN100-7.5	0 ~ 80 V	0 ~ 7.5 A	750 W	
GEN100-15		0 ~ 15 A	1500 W	
GEN100-24		0 ~ 24 A	2400 W	C
GEN150-5	0 ~ 100 V	0 ~ 5 A	750 W	
GEN150-10		0 ~ 10 A	1500 W	
GEN150-16		0 ~ 16 A	2400 W	
GEN300-2.5	0 ~ 150 V	0 ~ 2.5 A	750 W	
GEN300-5		0 ~ 5 A	1500 W	
GEN300-8		0 ~ 8 A	2400 W	B
GEN600-1.3	0 ~ 300 V	0 ~ 1.3 A	780 W	
GEN600-2.6		0 ~ 2.6 A	1560 W	
GEN600-4		0 ~ 4 A	2400 W	

How to order

Power Supply Identification / GENH 750 W 1 U

GEN H	600	- 1.3	-	- E
Series Name	Output Voltage (0~600 V)	Output Current (0~1.3 A)	Option: IEEE IS510 IS420 LAN	Factory Options

Factory Option GENH 750 W

Factory Option	P/N:
RS-232/RS-485 Interface Built-in Standard	-
IEEE 488.2 (GPIB) Interface	IEEE
Voltage Programming Isolated Analog Interface	IS510
Current Programming Isolated Analog Interface	IS420
LAN Interface (Complies with LXI class C)	LAN

How to order

Power Supply Identification GEN 750/1500 W 1 U

GEN	600	- 2.6	-	-
Series Name	Output Voltage (0~600 V)	Output Current (0~2.6 A)	Option: IEEE IS510 IS420 LAN	Factory Options

Factory Option GEN 750/1500 W

Factory Option	P/N:
RS-232/RS-485 Interface Built-in Standard	-
IEEE 488.2 (GPIB) Interface	IEEE
Voltage Programming Isolated Analog Interface	IS510
Current Programming Isolated Analog Interface	IS420
LAN Interface (Complies with LXI class C)	LAN

How to order

Power Supply Identification GEN 2400 W 1 U

GEN	8	- 300	-	-
Series Name	Output Voltage (0~8 V)	Output Current (0~300 A)	Option: IEEE IS510 IS420 LAN	Factory AC Input Options

Factory Option GEN 2400 W

Factory Option	P/N:
RS-232/RS-485 Interface Built-in Standard	-
IEEE 488.2 (GPIB) Interface	IEEE
Voltage Programming Isolated Analog Interface	IS510
Current Programming Isolated Analog Interface	IS420
LAN Interface (Complies with LXI class C)	LAN

* Development Priority

The new GEN 2.4 kW units will be introduced to the market during the year 2008. B-models will be available from January 2009 on. C-models will be available from April 2009 on. Please ask local Sales Office for latest status.

Models GEN 3.3 / 5 kW in 2 U 19" rack

Model	Output Voltage V DC	Output Current (A)	Output Power (W)	*
GEN-8-400	0 ~ 8 V	0 ~ 400 A	3200 W	
GEN-8-600		0 ~ 600 A	4800 W	
GEN-10-330	0 ~ 10 V	0 ~ 330 A	3300 W	
GEN-10-500		0 ~ 500 A	5000 W	C
GEN-15-220	0 ~ 15 V	0 ~ 220 A	3300 W	
GEN-16-310	0 ~ 16 V	0 ~ 310 A	4960 W	C
GEN-20-165	0 ~ 20 V	0 ~ 165 A	3300 W	
GEN-20-250		0 ~ 250 A	5000 W	
GEN-30-110	0 ~ 30 V	0 ~ 110 A	3300 W	
GEN-30-170		0 ~ 170 A	5100 W	
GEN-40-85	0 ~ 40 V	0 ~ 85 A	3400 W	
GEN-40-125		0 ~ 125 A	5000 W	
GEN-60-55	0 ~ 60 V	0 ~ 55 A	3300 W	
GEN-60-85		0 ~ 85 A	5100 W	
GEN-80-42	0 ~ 80 V	0 ~ 42 A	3360 W	
GEN-80-65		0 ~ 65 A	5200 W	C
GEN-100-33	0 ~ 100 V	0 ~ 33 A	3300 W	
GEN-100-50		0 ~ 50 A	5000 W	C
GEN-150-22	0 ~ 150 V	0 ~ 22 A	3300 W	
GEN-150-34		0 ~ 34 A	5100 W	
GEN-300-11	0 ~ 300 V	0 ~ 11 A	3300 W	
GEN-300-17		0 ~ 17 A	5100 W	
GEN-600-5.5	0 ~ 600 V	0 ~ 5.5 A	3300 W	
GEN-600-8.5		0 ~ 8.5 A	5100 W	

How to order

Power Supply Identification GEN 3.3 / 5 kW in 2 U

GEN	8	- 400	-	-
Series Name	Output Voltage (0~8 V)	Output Current (0~400 A)	Factory Options Option: IEEE IS510 IS420 LAN	Factory AC Input Options 1P230 (Single Phase 230 V AC) 3.3 kW only 3P208 (Three Phase 208 V AC) 3P400 (Three Phase 400 V AC)

Factory Option GEN 3.3 / 5 kW

RS-232/RS-485 Interface Built-in Standard	-
IEEE 488.2 (GPIB) Interface	IEEE
Voltage Programming Isolated Analog Interface	IS510
Current Programming Isolated Analog Interface	IS420
LAN Interface (Complies with LXI class C)	LAN

* Development Priority

The new GEN 5 kW units will be introduced to the market during the year 2008. C-models will be available from January 2009 on. Please ask local Sales Office for latest status.

Models GEN 10 / 15 kW in 3 U 19" rack

Model	Output Voltage V DC	Output Current (A)	Output Power (W)
GEN-7.5-1000	0 ~ 7.5 V	0 ~ 1000 A	7.5 kW
GEN-10-1000	0 ~ 10 V	0 ~ 1000 A	10 kW
GEN-12.5-800	0 ~ 12.5 V	0 ~ 800 A	10 kW
GEN-20-500	0 ~ 20 V	0 ~ 500 A	10 kW
GEN-25-400	0 ~ 25 V	0 ~ 400 A	10 kW
GEN-30-333	0 ~ 30 V	0 ~ 333 A	10 kW
GEN-40-250	0 ~ 40 V	0 ~ 250 A	10 kW
GEN-50-200	0 ~ 50 V	0 ~ 200 A	10 kW
GEN-60-167	0 ~ 60 V	0 ~ 167 A	10 kW
GEN-60-250		0 ~ 250 A	15 kW
GEN-80-125	0 ~ 80 V	0 ~ 125 A	10 kW
GEN-80-187.5		0 ~ 187.5 A	15 kW
GEN-100-100	0 ~ 100 V	0 ~ 100 A	10 kW
GEN-100-150		0 ~ 150 A	15 kW
GEN-125-80	0 ~ 125 V	0 ~ 80 A	10 kW
GEN-125-120		0 ~ 120 A	15 kW
GEN-150-66	0 ~ 150 V	0 ~ 66 A	10 kW
GEN-150-100		0 ~ 100 A	15 kW
GEN-200-50	0 ~ 200 V	0 ~ 50 A	10 kW
GEN-200-75		0 ~ 75 A	15 kW
GEN-250-40	0 ~ 250 V	0 ~ 40 A	10 kW
GEN-250-60		0 ~ 60 A	15 kW
GEN-300-33	0 ~ 300 V	0 ~ 33 A	10 kW
GEN-300-50		0 ~ 50 A	15 kW
GEN-400-25	0 ~ 400 V	0 ~ 25 A	10 kW
GEN-400-37.5		0 ~ 37.5 A	15 kW

Model	Output Voltage V DC	Output Current (A)	Output Power (W)
GEN-500-20	0 ~ 500 V	0 ~ 20 A	10 kW
GEN-500-30		0 ~ 30 A	15 kW
GEN-600-17	0 ~ 600 V	0 ~ 17 A	10 kW
GEN-600-25		0 ~ 25 A	15 kW

How to order

Power Supply Identification GEN 10/15 kW

GEN	10	- 1000	- MD	-
Series Name	Output Voltage (0~10 V)	Output Current (0~1000 A)	Factory Options Option: IEMD IS510 IS420 LAN	Factory AC Input Options 3P208 (Three Phase 208 V AC) 3P400 (Three Phase 400 V AC) 3P480 (Three Phase 480 V AC)

Factory Option GEN 10/15 kW

RS-232/RS-485 Interface Built-in Standard	-
GPIB (Multi Drop Master) Interface	IEMD
Voltage Programming Isolated Analog Interface	IS510
Current Programming Isolated Analog Interface	IS420
LAN Interface (Complies with LXI class C)	LAN

Front panel description

GENH 750 W



GEN 750/1500/2400 W in 1 U



1. ON/OFF Switch
2. Air Intake allows zero stacking for maximum system flexibility and power density.
3. Reliable encoder controls Output Voltage and sets Address, OVP, UVL Limits.
4. Volt Display shows Output Voltage and directly displays OVP, UVL and Address settings.
5. Reliable encoder controls Output Current, sets Baud rate and Advanced Parallel Mode.
6. Current Display shows Output Current and displays Baud rate. Displays total current in Parallel Master/ Slave Mode.

7. Function/Status LEDs:

- Alarm
- Fine Control
- Preview Settings
- Foldback Mode
- Remote Mode
- Output On

8. Pushbuttons allow flexible user configuration:

- Coarse and Fine adjustment of Output Voltage/Current and Advanced Parallel Master/Slave Mode.
- Preview settings and set Voltage/Current with Output OFF, Front Panel Lock.
- Parallel Master/Slave
- Set OVP and UVL Limits
- Set Current Foldback
- Local/Remote Mode and select Address and Baud rate.
- Output ON/OFF and Auto-Re-Start/Safe-Start Mode.

Rear panel description

GENH 750 W



GEN 750/1500/2400 W in 1 U

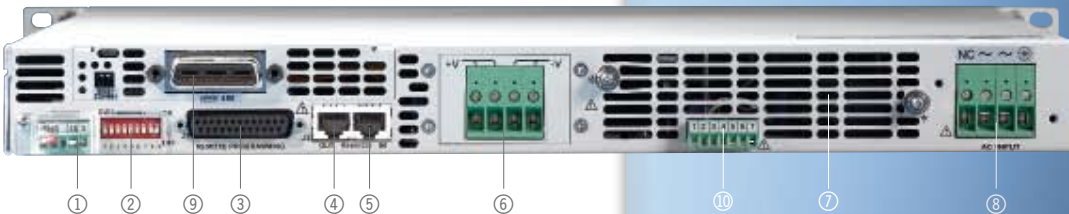

1. Remote/Local Output Voltage Sense Connections.
2. DIP Switches select 0–5 V or 0–10 V Programming and other functions.
3. DB25 (Female) connector allows (Non-isolated) Analog Program and Monitor and other functions.
4. RS-485 OUT to other Genesys™ Power Supplies.
5. RS-232/RS-485 IN Remote Serial Programming.
6. Output Connections:
 - 750 W (shown) /1500 W units: Rugged busbars up to 60 V Output. Wire clamp terminal for output 80 to 600 V models.
 - 2400 W units (shown): Rugged busbars up to 100 V Output. Wire clamp terminal for output 150 to 600 V models.

7. Exit air assures reliable operation when zero stacked.
8. Input:
 - IEC 320 connector for 750 W models (85 – 265 V AC)
 - Wire clamp terminal with strain relief for 1500 W models
 - 230 V AC Single Phase (GEN 2.4 kW – shown), 208 V AC Three Phase, 50/60 Hz
 - AC Input Connector: Phoenix P/N: FRONT-4-H-7.62.
9. Optional Interface Position for IEEE 488.2 SCPI or Isolated Analog Interface or LAN interface.
10. Auxiliary Output Voltage. 5 V/0.2 A (isolated), 15 V/0.2 A (non-isolated). GEN 2.4 kW only.

Front panel description

GEN 3 / 5 kW in 2 U

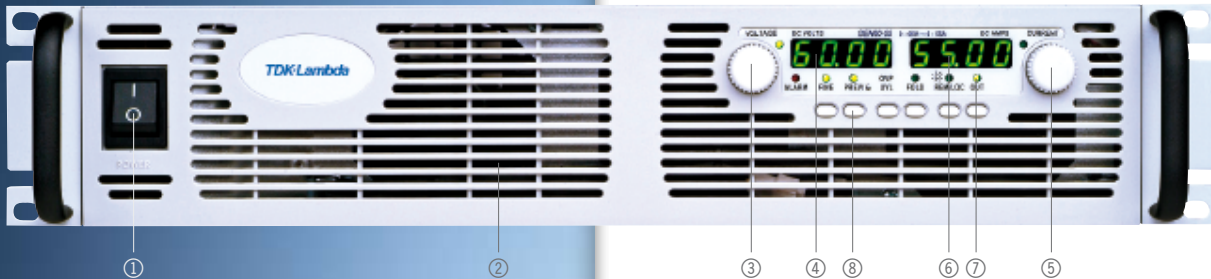

GEN 10 / 15 kW in 3 U

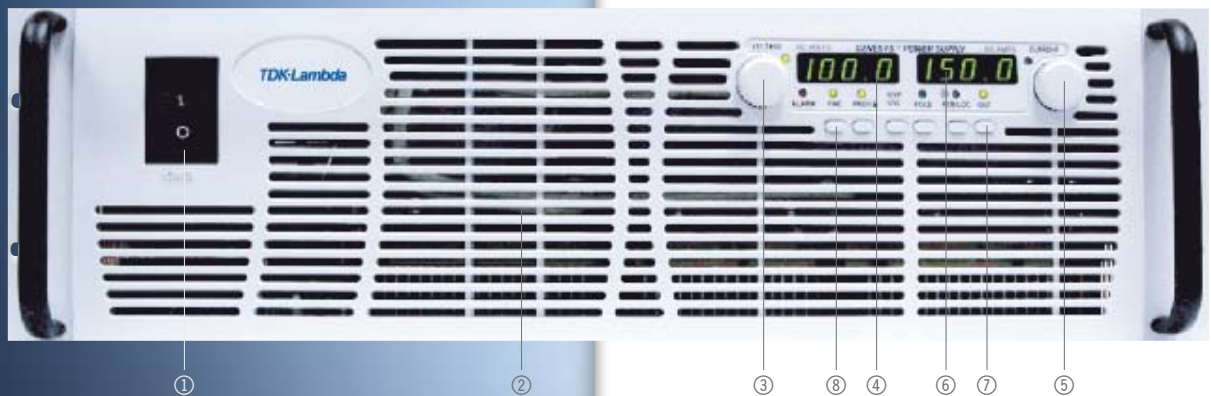

1. ON/OFF Switch
2. Air Intake allows zero stacking for maximum system flexibility and power density.
3. Reliable encoder controls Output Voltage and sets Address and Baud rate.
4. Volt Display shows Output Voltage and directly displays OVP, UVL and Address settings.
5. Reliable encoder controls Output Current, sets Baud rate and Advanced Parallel Mode.
6. Current Display shows Output Current and displays Baud rate. Displays total current in Parallel Master/Slave Mode.
7. Function/Status LEDs:
 - Alarm
 - Fine Control
 - Preview Settings
 - Foldback Mode
 - Remote Mode
 - Output On
8. Pushbuttons allow flexible user configuration:
 - Coarse and Fine adjustment of Output Voltage/Current and Advanced Parallel Master/Slave Mode.
 - Preview settings and set Voltage/Current with Output OFF, Front Panel Lock
 - Parallel Master/Slave
 - Set OVP and UVL Limits
 - Set Current Foldback
 - Local/Remote Mode and select Address and Baud rate
 - Output ON/OFF and Auto-Re-Start/Safe-Start Mode

Rear panel description

GEN 3 / 5 kW in 2 U

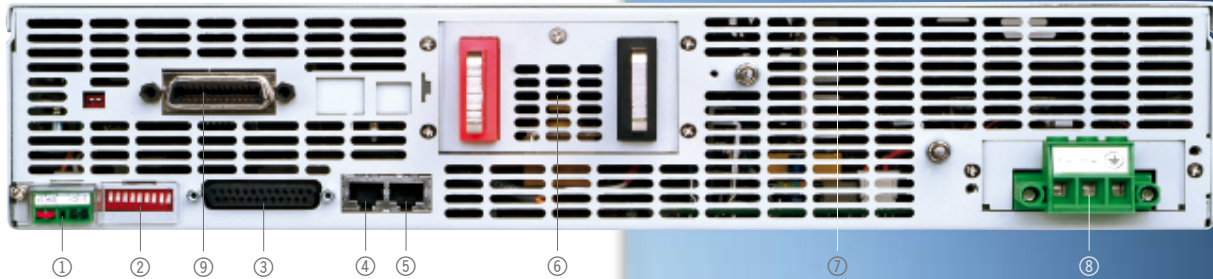

GEN 10 / 15 kW in 3 U

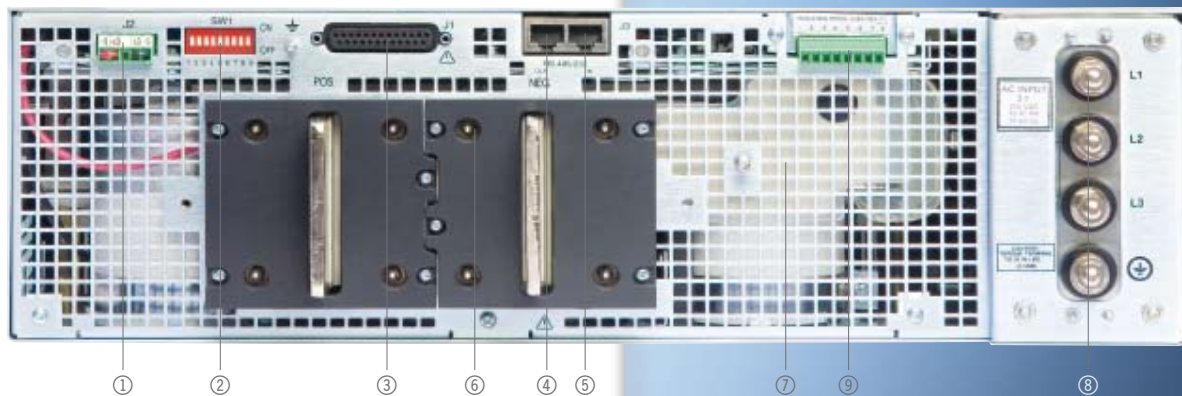

1. Remote/Local Output Voltage Sense Connections.
2. DIP Switches select 0–5 V or 0–10 V Programming and other functions.
3. DB25 (Female) connector allows (Non-isolated) Analog Program and Monitor and other functions.
4. RS-485 OUT to other Genesys™ Power Supplies.
5. RS-232/RS-485 IN Remote Serial Programming.
6. Output Connections:
 - Rugged busbars (shown) for up to 100 V Output
 - Wire clamp connector for Outputs >100 V for 10 kW and 15 kW models
 - Rugged 2 hole busbars (shown) for up to 80 V output
 - Single hole busbars 100 V to 300 V output
 - Threaded stud terminals above 300 V output
7. Exit air assures reliable operation when zero stacked.
8. Input:
 - AC Input Connector: PHOENIX CONTACT Power Combicon PC 6/... Series with strain relief for 3.3 kW and 5 kW models
 - Input Terminals L1, L2, L3, Ground, threaded studs for 10 kW and 15 kW models
9. Optional Interfaces Position for IEEE 488.2 (GPIB), Isolated Analog Interface or LAN interface.

Specifications Genesys™ GEN/GENH 750 W / 1500 W

1.0 Model	GEN	6-200	8-180	12.5-120	20-76	30-50
1. Rated output voltage (*1)	V	6	8	12.5	20	30
2. Rated output current (*2)	A	200	180	120	76	50
3. Rated output power	W	1200	1440	1500	1520	1500
4. Efficiency at 100/200 V AC (*3)	%	77/79	78/81	81/84	83/86	83/86
1.0 Model	GEN	6-100	8-90	12.5-60	20-38	30-25
1. Rated output voltage (*1)	V	6	8	12.5	20	30
2. Rated output current (*2)	A	100	90	60	38	25
3. Rated output power	W	600	720	750	760	750
1.0 Model	GENH	6-100	8-90	12.5-60	20-38	30-25
1. Rated output voltage (*1)	V	6	8	12.5	20	30
2. Rated output current (*2)	A	100	90	60	38	25
3. Rated output power	W	600	720	750	760	750
4. Efficiency at 100/200 V AC (*3)	%	76/78	77/80	81/84	82/85	83/87
1.1 Constant Voltage Mode						
1. Max. line regulation (0.01 % of Vo + 2 mV) (*4)	mV	2.6	2.8	3.3	4	5
2. Max. load regulation (0.01 % of Vo + 2 mV) (*5)	mV	2.6	2.8	3.3	4	5
3. Ripple and noise p-p 20 MHz (*9)	mV	60	60	60	60	60
4. Ripple RMS 5 Hz~1 MHz (*9)	mV	8	8	8	8	8
5. Remote sense compensation/line	V	1	1	1	1	1.5
6. Temperature coefficient	ppm/°C	100 ppm/°C of rated output voltage, following 30 minutes warm up				
7. Up-prog. response time, 0~Vo Rated	ms	80 ms, N.L / F.L, resistive load				
8. Down-prog. response time full-load	ms	10	50	50	50	80
9. Down-prog. response time no-load	ms	500	600	700	800	900
10. Transient response time (*8)		Less than 1 ms for models up to and including 100 V. 2 ms for models above 100 V				
1.2 Constant Current Mode						
1. Max. line regulation (0.01 % of Io + 2 mA) (*4)	mA	12	11	8.0	5.8	4.5
2. Max. load regulation (0.02 % of Io + 5 mA) (*6)	mA	25	23	17	12.6	10
3. Ripple RMS 5 Hz~1 MHz (*7)	mA	200	180	120	76	63
4. Max. line regulation (0.01 % of Io + 2 mA) (*4)	mA	22	20	14	9.6	7.0
5. Max. load regulation (0.02 % of Io + 5 mA) (*6)	mA	45	41	29	20.2	15
6. Ripple RMS 5 Hz~1 MHz (*7)	mA	400	360	240	152	125
7. Temperature coefficient	ppm/°C	100 ppm/°C from rated output voltage, following 30 minutes warm up				
1.3 Protective Functions						
1. OCP		0~105 % Constant Current				
2. OCP Foldback		Output shut-down when power supply change from CV to CC. User-selectable.				
3. OVP type		Inverter shut-down, manual reset by AC input recycle or by OUT button or by communication port.				
4. OVP trip point	V	0.5~7.5	0.5~10	1~15	1~24	2~36
5. Over Temperature Protection		User-selectable, latched or non-latched				

*1: Minimum voltage is guaranteed to maximum 0.2 % of Vo Rated.

*2: Minimum current is guaranteed to maximum 0.4 % of Io Rated.

*3: At maximum output power.

*4: 85~132 V AC or 170~265 V AC, constant load.

*5: From No-load to Full-load, constant input voltage.

*6: For load voltage change, equal to the unit voltage rating, constant input voltage.

								750 W	1500 W	
40-38	50-30	60-25	80-19	100-15	150-10	300-5	600-2.6		●	
40	50	60	80	100	150	300	600		●	
38	30	25	19	15	10	5	2.6		●	
1520	1500	1500	1520	1500	1500	1500	1560		●	
84/88	84/88	84/88	84/88	84/88	84/88	83/87	83/87	●	●	
40-19	–	60-12.5	80-9.5	100-7.5	150-5	300-2.5	600-1.3	●		
40	–	60	80	100	150	300	600	●		
19	–	12.5	9.5	7.5	5	2.5	1.3	●		
760	–	750	760	750	750	750	780	●		
40-19		60-12.5	80-9.5	100-7.5	150-5	300-2.5	600-1.3	●		
40		60	80	100	150	300	600	●		
19		12.5	9.5	7.5	5	2.5	1.3	●		
760		750	760	750	750	750	780	●		
83/87		84/88	84/88	84/88	84/88	83/87	83/87	●		
6	7	8	10	12	17	32	62	●	●	
6	7	8	10	12	17	32	62	●	●	
60	60	60	80	80	100	150	300	●	●	
8	8	8	8	8	10	25	60	●	●	
2	2	3	4	5	5	5	5	●	●	
								●	●	
150 ms, N.L./F.L, resistive load								250	●	●
80	80	80	150	150	150	150	250	●	●	
1000	1100	1100	1200	1500	2000	2500	4000	●	●	
								●	●	
3.9	–	3.25	2.95	2.75	2.5	2.25	2.13	●		
8.8	–	7.5	6.9	6.5	6.0	5.5	5.26	●		
48	–	38	29	23	18	13	8	●		
5.8	5	4.5	3.9	3.5	3.0	2.5	2.26		●	
12.6	11	10	8.8	8.0	7.0	6.0	5.52		●	
95	85	75	57	45	35	25	12		●	
								●	●	
								●	●	
								●	●	
2~44	5~57	5~66	5~88	5~110	5~165	5~330	5~660	●	●	
								●	●	

Sequel ►

*7: For 6 V models the ripple is measured at 2~6 V output voltage and full output current. For other models, the ripple is measured at 10~100 % output voltage and full output current.

*8: Time for the output voltage to recover within 0.5 % of its rated for a load change 10~90 % of rated output, Output set-point: 10~100 %.

*9: For 6 V~300 V models: measured with JEITA RC-9131 1:1 probe. For 600 V model: measured with 10:1 probe. Accuracy: Values have been calculated at Vo Rated & Io Rated.

Specifications Genesys™ GEN/GENH 750 W / 1500 W

1.4 Analog Programming and Monitoring						
1. Vout Voltage Programming	0~100 %, 0~5 V or 0~10 V, user-selectable. Accuracy and linearity: ±0.5 % of rated Vout.					
2. Iout Voltage Programming	0~100 %, 0~5 V or 0~10 V, user-selectable. Accuracy and linearity: ±1 % of rated Iout.					
3. Vout Resistor Programming	0~100 %, 0~5/10 k full scale, user-selectable. Accuracy and linearity: ±1 % of rated Vout.					
4. Iout Resistor Programming	0~100 %, 0~5/10 k full scale, user-selectable. Accuracy and linearity: ±1.5 % of rated Iout.					
5. On/Off control (rear panel)	By electrical. Voltage: 0~0.6 V/2~15 V, or dry contact, user-selectable logic					
6. Output current monitor	0~5 V or 0~10 V, accuracy: 1 %, user-selectable					
7. Output voltage monitor	0~5 V or 0~10 V, accuracy: 1 %, user-selectable					
8. Power supply OK signal	TTL high (4~5 V) -OK, 0 V-Fail 500 series resistance					
9. CV/CC indicator	CV: TTL high (4~5 V) source: 10 mA, CC: TTL low (0~0.6 V), sink current: 10 mA					
10. Enable/Disable	Dry contact. Open: off, Short: on. Max. voltage at Enable/Disable in: 6 V					
11. Local/Remote analog control	By electrical signal or Open/Short: 0~0.6 V or short: Remote, 4~5 V or open: Local					
12. Local/Remote analog control indicator	Open collector, Local: Open, Remote: On. Maximum voltage: 30 V, maximum sink current: 5 mA					
1.5 Front Panel						
1. Control functions	Vout/Iout manual adjust by separate encoders (coarse and fine adjustment selectable) OVP/UVL manual adjust by Volt. Adjust encoder AC on/off, Output on/off, Re-start modes (auto, safe), Foldback control (CV to CC), Go to local control Address selection by Voltage (or current) adjust encoder. Number of addresses: 31 RS232/485 and IEEE488.2 selection by IEEE enable switch and DIP switch Baud rate selection: 1200, 2400, 4800, 9600 and 19200					
2. Display	Voltage 4 digits, accuracy: 0.5 % ±1 count Current 4 digits, accuracy: 0.5 % ±1 count					
3. Indications	Voltage, Current, Alarm, Fine, Preview, Foldback, Local, Output On, Front Panel Lock					
1.6 Interface RS-232 & RS-485 or Optional GPIB / LAN Interface						
Model	V	6	8	12.5	20	30
1. Remote Voltage Programming (16 bit)						
Resolution (0.012 % of Vo Rated)	mV	0.72	0.96	1.50	2.40	3.60
Accuracy (0.05 % Vo Rated + 0.05 % of Vo Actual Output)	mV	6.0	8.0	12.5	20	30
2. Remote Current Programming (16 bit)						
Resolution (0.012 % of Io Rated)	mA	12	10.8	7.2	4.56	3.0
Accuracy (0.1 % of Io Rated + 0.1 % of Io Actual Output)	mA	200	180	120	76	50
Resolution (0.012 % of Io Rated)	mA	24	21.6	14.4	9.12	6.0
Accuracy (0.1 % of Io Rated + 0.1 % of Io Actual Output)	mA	400	360	240	152	100
3. Readback Voltage						
Resolution (0.012 % of Vo Rated)	mV	0.72	0.96	1.50	2.40	3.60
Accuracy (0.1 % Vo Rated + 0.1 % of Vo Actual Output)	mV	12	16	25	40	60

Specifications Genesys™ GEN/GENH 750 W / 1500 W

1.6 Interface RS232 & RS485 or Optional GPIB / LAN Interface						
Model	V	6	8	12.5	20	30
4. Readback Current						
Resolution (0.012 % of Io Rated)	mA	12	10.8	7.2	4.56	3.0
Accuracy (0.1 % of Io Rated + 0.3 % of Io Actual Output)	mA	400	360	240	152	100
Resolution (0.012 % of Io Rated)	mA	24	21.6	14.4	9.12	6
Accuracy (0.1 % of Io Rated + 0.3 % of Io Actual Output)	mA	800	720	480	304	200
5. OVP/UVL Programming						
Resolution (0.1 % of Vo Rated)	mV	6	8	12	20	30
Accuracy (1 % of Vo Rated)	mV	60	80	125	200	300

2.1 Input Characteristics	
1. Input voltage/freq. (*1)	85~265 V AC continuous, 47~63 Hz, single phase
2. Power Factor	0.99 @100/200 V AC, rated output power
3. EN61000-3-2,3 compliance	Complies with EN61000-3-2 class A and EN61000-3-3 at 20~100 % output power
4. Input current 100/200 V AC	10.5 A / 5 A (750 W), 21 A / 11 A (1500 W)
5. Inrush current 100/200 V AC	Less than 25 A (750 W), Less than 50 A (1500 W)
6. Hold-up time	More than 20 ms, 100 V AC, at 100 % load
2.2 Power Supply Configuration	
1. Parallel operation	Up to 4 units in master/slave mode with single wire current balance connection
2. Series operation	Up to 2 units with external diodes. 600 V max. to chassis ground
2.3 Environmental Conditions	
1. Operating temperature	0~50 °C, 100 % load
2. Storage temperature	-20~70 °C
3. Operating humidity	30~90 % RH (non-condensing)
4. Storage humidity	10~95 % RH (non-condensing)
5. Vibration	MIL-810E, method 514.4, test cond. I-3.3.1 The EUT is fixed to the vibrating surface
6. Shock	Less than 20 g, half sine, 11 ms unit is unpacked
7. Altitude	Operating: 10,000 ft (3,000 m), Derat output current by 2 %/100 m above 2,000 m, Non-operating: 40,000 ft (12,000 m)
2.4 EMC	
1. Applicable Standards:	
2. ESD	IEC1000-4-2. Air-disch. -8 kV, contact disch. -4 kV
3. Fast transients	IEC1000-4-4. 2 kV
4. Surge immunity	IEC1000-4-5. 1 kV line to line, 2 kV line to ground
5. Conducted immunity	IEC1000-4-6, 3 V
6. Radiated immunity	IEC1000-4-3, 3 V/m
7. Conducted emission	EN55022B, FCC part 15J-B, VCCI-B
8. Radiated emission	EN55022A, FCC part 15-A, VCCI-A
9. Voltage dips	EN61000-4-11
10. Conducted emission	EN55022B, FCC part 15-B, VCCI-B
11. Radiated emission	EN55022A, FCC part 15-A, VCCI-A

*1: For cases where conformance to various safety standards (UL, IEC etc.) is required, to be described as 100-240 V AC (50/60 Hz).

All specifications subject to change without notice.

								750 W	1500 W
40	50	60	80	100	150	300	600	●	●
2.28	–	1.50	1.14	0.90	0.60	0.30	0.16	●	
76	–	50	38	30	20	10	5.2	●	
4.56	3.60	3.0	2.28	1.80	1.20	0.60	0.32		●
152	120	100	76	60	40	20	10.4		●
40	50	60	80	100	150	300	600	●	●
400	500	600	800	1000	1500	3000	6000	●	●

2.5 Safety	
1. Applicable standards:	<p>CE Mark, UL60950-1, EN60950-1 listed.</p> <p>Vout ≤40 V: Output is SELV, IEEE/Isolated analog are SELV</p> <p>40 <Vout <400 V: Output is hazardous, IEEE/Isolated analog are SELV</p> <p>400 <Vout <600 V: Output is hazardous, IEEE/Isolated analog are not SELV</p>
2. Withstand voltage	<p>Vout <40 V models: Input-Outputs (SELV): 3.0 kV RMS 1min, Input-Ground: 2.0 kV RMS 1 min</p> <p>40 <Vout <600 V models: Input-Haz. Output: 2.5 kV RMS 1min, Input-SELV: 3 kV RMS 1 min</p> <p>Hazardous Output-SELV: 1.9 kV RMS 1 min, Hazardous Output-Ground: 1.9 kV RMS 1 min</p> <p>Input-Ground: 2 kV RMS 1 min</p>
3. Insulation resistance	More than 100 M at 25 °C, 70 % RH, 500 V DC
2.6 Mechanical Construction GENH 750 W	
1. Cooling	Forced air flow: from front to rear. No ventilation holes at the top or bottom of the chassis; Variable fan speed.
2. Dimensions (WxHxD)	W: 214.0 mm, H: 43.6 mm, (57.0 mm Benchtop version), D: 437.5 mm (excluding connectors, encoders, handles, etc.)
3. Weight	4.5 kg (9.9 lbs)
4. AC Input connector	IEC320 AC Inlet
5. Output connectors	6 V to 60 V models: Bus-bars (hole Ø 6.5 mm). 80 V to 600 V models: Meating plug, Phoenix P/N: GIC 2.54/4-ST-7.62
2.6 Mechanical Construction GEN 750 W/1500 W	
1. Cooling	Forced air flow: from front to rear. No ventilation holes at the top or bottom of the chassis; Variable fan speed.
2. Dimensions (WxHxD)	W: 422.8 mm, H: 43.6 mm, D: 432.8 mm (excluding connectors, encoders, handles, etc.)
3. Weight	750 W: 7 kg (15 lbs), 1500 W: 8.5 kg (18 lbs)
4. AC Input connector	750 W: IEC320 AC Inlet
	1500 W: Screw terminal block, Phoenix P/N: FRONT-4-H-7.62, with strain relief
5. Output connectors	6 V to 60 V models: Bus-bars (hole Ø 8.5 mm). 80 V to 600 V models: wire clamp connector, Phoenix P/N: FRONT-4-H-7.62
2.7 Reliability specs	
1. Warranty	5 years

Sequel ▶

Specifications Genesys™ 2400 W

1.0 Model	GEN	8-300	10-240	16-150	20-120
1. Rated output voltage (*1)	V	8	10	16	20
2. Rated output current (*2)	A	300	240	150	120
3. Rated output power	W	2400	2400	2400	2400
4. Efficiency (*3)	%	84	84	84	86
1.1 Constant Voltage Mode					
1. Max. line regulation (0.01 % of Vo + 2 mV) (*4)	mV	2.8	3	3.6	4
2. Max. load regulation (0.015 % of Vo + 5 mV) (*5)	mV	6.2	6.5	7.4	8
3. Ripple and noise p-p 20 MHz (*9)	mV	60	60	60	60
4. Ripple RMS 5 Hz~1 MHz (*10) mV	8	8	8	8	8
5. Remote sense compensation/line	V	2	2	2	2
6. Temperature coefficient	ppm/°C	100 ppm/°C of rated output voltage, following 30 minutes warm up			
7. Up-prog. response time, 0~Vo Rated (*7)	ms	15 ms, N.L / F.L, resistive load			
8. Down-prog. response time full-load (*7)	ms	10	30		
9. Down-prog. response time no-load (*8)	ms	500	600	700	800
10. Transient response time		Time for output voltage to recover within 0.5 % of its rated output for a load change 10 – 90 % of rated output current. Output set-point: 10 – 100 %, local sense. Less than 1 ms for models up to and including 100 V. 2 ms for models above 100 V			
1.2 Constant Current Mode					
1. Max. line regulation (0.01 % of Io + 2 mA) (*4)	mA	32	26	17	14
2. Max. load regulation (0.02 % of Io + 5 mA) (*6)	mA	65	53	35	29
3. Ripple RMS 5 Hz~1 MHz (*7)	mA	1200	960	600	480
4. Temperature coefficient	ppm/°C	100 ppm/°C from rated output voltage, following 30 minutes warm up			
1.3 Protective Functions					
1. OCP		0~105 % Constant Current			
2. OCP Foldback		Output shut-down when power supply change from CV to CC. User-selectable.			
3. OVP type		Inverter shut-down, manual reset by AC input recycle or by OUP button or by communication port.			
4. OVP trip point	V	0.5~10	0.5~12	1~19	1~24
5. Over Temperature Protection		User-selectable, latched or non-latched			

*1: Minimum voltage is guaranteed to maximum 0.2 % of rated output voltage.

*2: Minimum current is guaranteed to maximum 0.4 % of rated output current.

*3: 3-Phase 208 V models: At 208 V AC input voltage. With rated output power.

*4: 3-Phase 208 V models: 170~265 V AC, constant load.

*5: From No-load to Full-load, constant input voltage. Maximum drop in Remote Sense.

*6: For load voltage change, equal to the unit voltage rating, constant input voltage.

30-80	40-60	60-40	80-30	100-24	150-16	300-8	600-4
30	40	60	80	100	150	300	600
80	60	40	30	24	16	8	4
2400	2400	2400	2400	2400	2400	2400	2400
86	88	88	88	88	88	88	88
5	6	8	10	12	17	32	62
9.5	11	14	17	20	27.5	50	95
60	60	60	80	80	100	150	300
8	8	8	8	25	35	75	
5	5	5	5	5	5	5	5
60 ms, N.L / F.L, resistive load							100
30			80			100	
900	1000	1100	1200	1500	2500	3000	
10	8	6	5	4.4	3.6	2.8	2.4
21	17	13	11	9.8	8.2	6.6	5.8
220	120	70	50	40	30	15	7
2~36	2~44	5~66	5~88	5~110	5~165	5~330	5~660
							Sequel ▶

*7: From 10 % to 90 % or 90 % to 10 % of rated output voltage, with rated, resistive load.

*8: From 90 % to 10 % of rated output voltage.

*9: For 8 V~300 V models: measured with JEITA RC-9131 1:1 probe.
For 600 V model: measured with 10:1 probe.

*10: For 8 V~16 V models the ripple is measured from 2 V to rated output voltage and rated output current. For other models, the ripple is measured at 10~100 % of rated output voltage and rated output current.

Specifications Genesys™ 2400 W

1.4 Analog Programming and Monitoring					
1. Vout Voltage Programming	0~100 %, 0~5 V or 0~10 V, user-selectable. Accuracy and linearity: ±0.5 % of rated Vout.				
2. Iout Voltage Programming (*11)	0~100 %, 0~5 V or 0~10 V, user-selectable. Accuracy and linearity: ±1 % of rated Iout.				
3. Vout Resistor Programming	0~100 %, 0~5/10 k full scale, user-selectable. Accuracy and linearity: ±1 % of rated Vout.				
4. Iout Resistor Programming (*11)	0~100 %, 0~5/10 k full scale, user-selectable. Accuracy and linearity: ±1.5 % of rated Iout.				
5. On/Off control (rear panel)	By electrical. Voltage: 0~0.6 V/2~15 V, or dry contact, user-selectable logic				
6. Output current monitor	0~5 V or 0~10 V, accuracy: ±1 %, user-selectable				
7. Output voltage monitor	0~5 V or 0~10 V, accuracy: ±1 %, user-selectable				
8. Power supply OK signal	TTL high (4~5 V) -OK, 0 V-Fail 500 series resistance				
9. CV/CC indicator	Open Collector, CC mode: On, CV mode: Off. Maximum voltage: 30 V, maximum sink current: 10 mA				
10. Enable/Disable	Dry contact. Open: off, Short: on. Max. voltage at Enable/Disable in: 6 V				
11. Local/Remote analog control	By electrical signal or Open/Short: 0~0.6 V or short: Remote, 4~5 V or open: Local				
12. Local/Remote analog control indicator	Open collector, Local: Open, Remote: On. Maximum voltage: 30 V, maximum sink current: 5 mA				
1.5 Front Panel					
1. Control functions	Vout/Iout manual adjust by separate encoders (coarse and fine adjustment selectable) OVP/UVL manual adjust by Volt. Adjust encoder AC on/off, Output on/off, Re-start modes (auto, safe), Foldback control (CV to CC), Go to local control Address selection by Voltage (or current) adjust encoder. Number of addresses: 31 RS-232 / RS-485 and IEEE488.2 selection by IEEE enable switch and DIP switch Baud rate selection: 1200, 2400, 4800, 9600 and 19200				
2. Display	Voltage 4 digits, accuracy: 0.5 % ±1 count Current 4 digits, accuracy: 0.5 % ±1 count				
3. Indications	Voltage, Current, Alarm, Fine, Preview, Foldback, Local, Output On, Front Panel Lock, CV/CC				
1.6 Interface RS-232 & RS-485 or Optional GPIB / LAN Interface					
Model	V	8	10	16	20
1. Remote Voltage Programming (16 bit)					
Resolution (0.012 % of Vo Rated)	mV	0.96	1.2	1.92	2.40
Accuracy (0.05 % Vo Rated + 0.05 % of Vo Actual Output)	mV	8	10	16	20
2. Remote Current Programming (16 bit)					
Resolution (0.012 % of Io Rated)	mA	36	28.8	18	14.4
Accuracy (0.2 % of Io Rated + 0.1 % of Io Actual Output) (13*)	mA	900	720	450	360
3. Readback Voltage					
Resolution (0.012 % of Vo Rated)	mV	0.96	1.2	1.92	2.40
Accuracy (0.1 % Vo Rated + 0.1 % of Vo Actual Output)	mV	16	20	32	40

*11: The Constant Current programming readback and monitoring accuracy does not include the warm-up and load regulation thermal drift.

*12: For cases where conformance to various safety standards (UL, IEC, etc.) is required, to be described as 190 – 240 V AC (50/60 Hz) for 3-phase 208 V models.

30	40	60	80	100	150	300	600
3.60	4.80	7.2	9.6	12	18	36	72
30	40	60	80	100	150	300	600
9.6	7.2	4.8	3.6	2.88	1.92	0.96	0.48
240	180	120	90	72	48	24	12
3.60	4.80	7.2	9.6	12	18	36	72
60	80	120	160	200	300	600	1200
							Sequel ▶

*13: For cases where conformance to various safety standards (UL, IEC, etc) is required, to be described as 190-240 V AC (50/60 Hz) for single phase and 3-Phase 208 V models, and 380-415 V AC (50/60 Hz) for 3-Phase 400 V models.

Specifications Genesys™ 2400 W

1.6 Interface RS-232 & RS-485 or Optional GPIB / LAN Interface					
Model	V	8	10	16	20
4. Readback Current					
Resolution (0.012 % of Io Rated)	mA	36	28.8	18	14.4
Accuracy (0.3 % of Io Rated + 0.1 % of Io Actual Output) (*11)	mA	1200	960	600	480
5. OVP/UVL Programming					
Resolution (0.1 % of Vo Rated)	mV	8	10	16	20
Accuracy (1 % of Vo Rated)	mV	80	100	160	200

2.1. Input Characteristics	GEN	8-300	10-240	16-150	20-120
1. Input voltage/freq. (*12)	V AC	Single Phase, 230 V models: 170~265 V AC, 47~63 Hz 3-Phase, 208 V models: 170~265 V AC, 47~63 Hz			
2. Maximum Input current at 100 % load Single Phase, 230 V models 3-Phase, 208 V models	A A	17 10.5	17 10.5	17 10.5	16.3 9.8
3. Power Factor (Typ)		Single Phase models: 0.99@230 V AC, rated output power. 3-Phase models: 0.94@208 V AC, rated output power			
4. Efficiency (*13)	%	84	84	84	86
5. Inrush Current (*14)	A	Single Phase and 3-Phase 208 V models: Less than 50 A			
6. Hold-up time (Typ)	ms	10 ms for Single Phase and 3-Phase 208 V models. Rated output power			

*12: For cases where conformance to various safety standards (UL, IEC, etc.) is required, to be described as 190 – 240 V AC (50/60 Hz) for 3-phase 208 V models.

*13: For cases where conformance to various safety standards (UL, IEC, etc.) is required, to be described as 190–240 V AC (50/60 Hz) for single phase and 3-Phase 208 V models, and 380~415 V AC (50/60 Hz) for 3-Phase 400 V models.

2.2 Auxiliary Output	
1. 15 V output	15 V ±5 %, 0.2 A Max. load, Ripple & Noise 50 mV p-p. Referenced internally to the negative output potential.
2. 5 V output	5 V ±5 %, 0.2 A Max. load, Ripple & Noise 50 mV p-p. Referenced internally to IF_com potential.
2.3 Power Supply Configuration	
1. Parallel operation	Up to 4 identical units in master/slave mode
2. Series operation	Up to 2 identical units with external diodes. 600 V max. to chassis ground
2.4 Environmental Conditions	
1. Operating temperature	0~50 °C, 100 % load
2. Storage temperature	-20~85 °C
3. Operating humidity	20~90 % RH (non-condensing)
4. Storage humidity	10~95 % RH (non-condensing)
5. Vibration	MIL-810F, method 514.4, The EUT is fixed to the vibrating surface
6. Shock	Less than 20 g, half sine, 11 ms, unit is unpacked
7. Altitude	Operating: 10,000 ft (3,000 m), Derate output current by 2 % / 100 m above 2,000 m. Alternatively, derate maximum ambient temperature by 1 °C / 100 m above 2,000 m. Non-operating: 40,000 ft (12,000 m)
8. RoHS Compliance	Complies with the requirements of RoHS directive.
2.5 EMC	
1. Applicable Standards:	
2. ESD	IEC1000-4-2. Air-disch. -8 kV, contact disch. -4 kV
3. Fast transients	IEC1000-4-4. 2 kV
4. Surge immunity	IEC1000-4-5. 1 kV line to line, 2 kV line to ground
5. Conducted immunity	IEC1000-4-6, 3 V
6. Radiated immunity	IEC1000-4-3, 3 V/m
7. Magnetic field immunity	EN61000-4-8, 1 A/m
8. Voltage dips	EN61000-4-11
9. Conducted emission	EN55022A, FCC part 15-A, VCCI-A
10. Radiated emission	EN55022A, FCC part 15-A, VCCI-A

30	40	60	80	100	150	300	600
9.6	7.2	4.8	3.6	2.88	1.92	0.96	0.48
320	240	160	120	96	64	32	16
30	40	60	80	100	150	300	600
300	400	600	800	1000	1500	3000	6000

30-80	40-60	60-40	80-30	100-24	150-16	300-8	600-4
16.3 9.8	16.3 9.8	16.3 9.8	16.3 9.8	16.3 9.8	16.3 9.8	16.3 9.8	16.3 9.8
86	88	88	88	88	88	88	88

*14: For 8 V~16 V models the ripple is measured from 2 V to rated output voltage and rated output current. For other models, the ripple is measured at 10~100 % of rated output voltage and rated output current.

2.6 Safety	
1. Applicable standards	CE Mark, UL60950, EN60950 listed. Vout ≤40 V: Output is SELV, IEEE/Isolated analog are SELV 40 <Vout ≤400 V: Output is hazardous, IEEE/Isolated analog are SELV 400 <Vout ≤600 V: Output is hazardous, IEEE/Isolated analog are not SELV
2. Withstand voltage	Vout ≤40 V models: Input-Outputs (SELV): 4242 V DC 1min, Input-Ground: 2828 V DC 1 min 40 <Vout ≤100 V models: Input-Haz. Output: 2600 V DC 1min, Input-SELV: 4242 V DC 1 min Hazardous Output-SELV: 1900 V DC 1 min, Hazardous Output-Ground: 1200 V DC 1 min, Input-Ground: 2828 V DC 1 min 100 <Vout ≤600 V models: Input-Haz. Output: 4000 V DC 1min, Input-SELV: 4242 V DC 1 min Hazardous Output-SELV: 3550 V DC 1 min, Hazardous Output-Ground: 2670 V DC 1 min, Input-Ground: 2828 V DC 1 min
3. Insulation resistance	More than 100 M at 25 °C, 70 % RH
2.7 Mechanical Construction	
1. Cooling	Forced air flow: from front to rear. No ventilation holes at the top or bottom of the chassis; Variable fan speed.
2. Dimensions (WxHxD)	W: 423.0 mm, H: 43.6 mm, D: 432.8 mm (excluding connectors, encoders, handles, etc.)
3. Weight	10 kg
4. AC Input connector (with Protective Cover)	Single Phase, 230 V models, wire clamp connector, Phoenix P/N: FRONT-4-H-7.62, with Stain relief 3-Phase, 208 V models, wire clamp connector, Phoenix P/N: FRONT-4-H-7.62, with Stain relief
5. Output connectors	8 V to 100 V models: Bus-bars (hole Ø 8.5 mm). 150 V to 600 V models: wire clamp connector, Phoenix P/N: FRONT-4-H-7.62 Auxiliary output header: IMC 1.5/7-G-3.81, Plug: IMC 1.5/7-ST-3.81 (Phoenix Contact)
2.8 Reliability specs	
1. Warranty	5 years
Sequel ▶	
All specifications subject to change without notice.	

Specifications Genesys™ 3.3 kW / Genesys™ 5 kW

1.0 Model	GEN	8-400	8-600	10-330	10-500	15-220	16-310	20-165	20-250
1. Rated output voltage (*1)	V	8	8	10	10	15	16	20	20
2. Rated output current (*2)	A	400	600	330	500	220	310	165	250
3. Rated output power	W	3200	4800	3300	5000	3300	4960	3300	5000
1.1 Constant Voltage Mode									
1. Max. line regulation (0.01 % of rated Vo + 2 mV) (*3)	mV	2.8	0.8	3	1.0	3.5	1.6	4	2
2. Max. load regulation (0.015 % of rated Vo + 5 mV) (*4)	mV	6.2	6.2	6.5	6.5	7.25	7.4	8	8
3. Ripple and noise p-p 20 MHz (*5)	mV	60	75	60	75	60	75	60	75
4. Ripple RMS 5 Hz~1 MHz	mV	8	10	8	10	8	10	8	10
5. Remote sense compensation/wire	V	2	2	2	2	2	2	2	2
6. Temperature coefficient	ppm/°C	100 ppm/°C of rated output voltage, following 30 minutes warm-up.							
7. Temperature stability		0.05 % of rated Vout over 8 hrs interval following 30 minutes warm-up. Constant line, load & temperature.							
8. Warm-up drift		Less than 0.05 % of rated output voltage + 2 mV over 30 minutes following power On.							
9. Up-prog. response time, 0~Vo Rated (*6)	ms	80 / 30							
10. Down-prog. response time	Full-load (*6)	ms	20	15	100 / 50				
	No-load (*7)	ms	500	400	600	500	700	800	800
11. Transient response time	ms	Time for output voltage to recover within 0.5 % of its rated output for a load change 10–90 % of rated output current. Output set-point: 10–100 %, local sense. Less than 1 ms for models up to and including 100 V. 2 ms for models above 100 V.							
1.2 Constant Current Mode									
1. Max. line regulation (0.01 % of rated Io + 2 mA) (*3)	mA	42	300	35	250	24	155	18.5	125
2. Max. load regulation (0.02 % of rated Io + 5 mA) (*8)	mA	85	600	71	500	49	310	38	250
3. Ripple RMS 5 Hz~1 MHz (*9)	mA	1300	1950	1200	1800	880	1400	6	1000
4. Load regulation thermal drift		Less than 0.1 % of rated output current over 30 minutes following load change.							
5. Temperature coefficient	ppm/°C	200 ppm/°C / 100 ppm/°C from rated output current, following 30 minutes warm-up.							
6. Temperature stability		0.05 % of rated Iout over 8 hrs interval following 30 minutes warm-up. Constant line, load & temperature.							
7. Warm-up drift		8~40 V model: Less than ±0.5 % rated output current over 30 minutes following power On. (8 ~16 V model) 60~600 V model: Less than ±0.25 % of rated output current over 30 minutes following power On. (20 ~600 V model)							

*1: Minimum voltage is guaranteed to maximum 0.2 % of rated output voltage.

*2: Minimum current is guaranteed to maximum 0.4 % of rated output current.

*3: Single-Phase and 3-Phase 208 V models: 170~265 V AC, constant load. 3-Phase 400 V models: 342~460 V AC, constant load.

*4: From No-Load to Full-Load, constant input voltage. Maximum drop in Remote Sense.

*5: For 8 V~300 V models: Measured with JEITA RC-9131A (1:1) probe. For 600 V model: Measured with 10:1 probe.

*6: From 10 % to 90 % or 90 % to 10 % of Rated Output Voltage, with rated, resistive load.

Specifications Genesys™ 3.3 kW / Genesys™ 5 kW

1.3 Protective Functions	GEN	8-400	8-600	10-330	10-500	15-220	16-310	20-165	20-250	30-110	
1. OCP		0~105 % Constant current									
2. OCP foldback		Output shut-down when power supply change from CV to CC. User-selectable.									
3. OVP type		Inverter shut-down, manual reset by AC input recycle or by OUT button or by communication port command.									
4. OVP trip point		0.5~10 V		0.5~12 V		1~19 V		1~24 V		2~36 V	
5. Output under voltage limit		Preset by front panel or communication port. Prevents from adjusting Vout below limit.									
6. Over temperature protection		User-selectable, latched or non-latched.									
1.4 Analog programming and monitoring											
1. Vout Voltage Programming		0~100 %, 0~5 V or 0~10 V, user-selectable. Accuracy and linearity: ± 0.5 % of rated Vout.									
2. Iout Voltage Programming (*10)		0~100 %, 0~5 V or 0~10 V, user-selectable. Accuracy and linearity: ± 1 % of rated Iout.									
3. Vout Resistor Programming		0~100 %, 0~5/10 k full scale, user-selectable. Accuracy and linearity: ± 1 % of rated Vout.									
4. Iout Resistor Programming (*10)		0~100 %, 0~5/10 k full scale, user-selectable. Accuracy and linearity: ± 1.5 % of rated Iout.									
5. On/Off control (rear panel)		By electrical. Voltage: 0~0.6 V/2~15 V, or dry contact, user-selectable logic.									
6. Output Current monitor (*10)		0~5 V or 0~10 V, Accuracy: ± 1 %, user-selectable.									
7. Output Voltage monitor		0~5 V or 0~10 V, Accuracy: ± 1 %, user-selectable.									
8. Power Supply OK signal		TTL high (4~5 V) -OK, 0 V-Fail 500 series resistance.									
9. CV/CC Indicator		CV: TTL high (4~5 V) source: 10 mA, CC: TTL low (0~0.6 V), sink current: 10 mA.									
10. Enable/Disable		Dry contact. Open: off, Short: on. Max. voltage at Enable/Disable in: 6 V.									
11. Local/Remote analog control		By electrical signal or Open/Short: 0~0.6 V or short: Remote, 4~5 V or open: Local.									
12. Local/Remote analog control Indicator		Open collector, Local: Off, Remote: On. Maximum voltage: 30 V, maximum sink current: 10 mA.									
1.5 Front Panel											
1. Control functions		Vout/Iout manual adjust by separate encoders (coarse and fine adjustment selectable).									
		OVP/UVL manual adjust by Volt. Adjust encoder.									
		On/Off, Output on/off, Re-start modes (auto, safe), Foldback control (CV to CC), Go to local control.									
		Address selection by Voltage (or current) adjust encoder. Number of addresses: 31.									
		Re-start modes (automatic restart, safe mode).									
2. Display		Baud rate selection: 1200, 2400, 4800, 9600 and 19200.									
		Voltage: 4 digits, Accuracy: 0.5 % of rated output voltage ± 1 count.									
3. Indications		Current: 4 digits, Accuracy: 0.5 % of rated output current ± 1 count.									
		Voltage, Current, Alarm, Fine, Preview, Foldback, Local, Output On, Front Panel Lock, CV/CC.									
1.6 Interface RS 232 & RS 485 or Optional GPIB / LAN Interface											
Model	V	8	10	15	16	20	30				
1. Remote Voltage Programming (16 bit)	Resolution (0.012 % of Vo Rated)	mV	0.96	1.2	1.8	1.92	2.4	3.6			
	Accuracy (0.05 % Vo Rated + 0.05 % of Vo Actual Output)	mV	8	10	15	20	30				
2. Remote Current Programming (16 bit)	Resolution (0.012 % of Io Rated)	mA	48	72	39.6	60	26.4	37.2	19.8	30	13.2
	Accuracy (0.2 % of Io Rated + 0.1 % of Io Actual Output) (*10)	mA	1200	2400	990	2000	660	1240	495	1000	330

*10: The Constant Current programming readback and monitoring accuracy does not include the warm-up and Load regulation thermal drift.

30-170	40-85	40-125	60-55	60-85	80-42	80-65	100-33	100-50	150-22	150-34	300-11	300-17	600-5.5	600-8.5
--------	-------	--------	-------	-------	-------	-------	--------	--------	--------	--------	--------	--------	---------	---------

	2~44 V	5~66 V	5~88 V	5~110 V	5~165 V	5~330 V	5~660 V
--	--------	--------	--------	---------	---------	---------	---------

	40		60		80		100		150		300		600	
	4.8		7.2		9.6		12		18		36		72	
	40		60		80		100		150		300		600	
20.4	10.2	15	6.6	10.2	5.0	7.8	4.0	6.0	2.6	4.08	1.3	2.04	0.7	1.02
680	255	500	165	340	126	260	99	200	66	136	33	68	16.5	34

Sequel ►

Specifications Genesys™ 3.3 kW / Genesys™ 5 kW

Sequel to 1.6 Interface RS-232 & RS-485 or Optional GPIB / LAN Interface									
Model	V	8		10		15	16	20	
3. Readback Voltage									
Resolution (0.012 % of Vo Rated)	mV	0.96		1.2		1.8	1.92	2.4	
Accuracy (0.1 % Vo Rated + 0.1 % of Vo Actual Output)	mV	16		20	15	30	24	40	30
4. Readback Current									
Resolution (0.012 % of Io Rated)	mA	48	72	39.6	60	26.4	37.2	19.8	30
Accuracy (0.3 % of Io Rated + 0.1 % of Io Actual Output) (*10)	mA	1600	2400	1320	2000	880	1240	660	1000
5. OVP/UVL Programming									
Resolution (0.1 % of Vo Rated)	mV	8		10		15	16	20	
Accuracy (1 % of Vo Rated)	mV	80		100		150	160	200	

*10: The Constant Current programming readback and monitoring accuracy does not include the warm-up and Load regulation thermal drift.

2.1 Input Characteristics		GEN	8-400	8-600	10-330	10-500	15-220	16-310	20-165	20-250	30-110
1. Input voltage/freq. (*1)		V AC	Single Phase, 230 V models: 170~265 V AC, 47~63 Hz (only available for 3.3 kW models)								
2. Maximum Input current at 100 % load	Single Phase, 230 V models	A	24	–	24	–	24	–	24	–	24
	3-Phase, 208 V models	A	15	21	15	22	15	22	15	22	15
	3-Phase, 400 V models	A	7.5	10.5	7.5	11	7.5	11	7.5	11	7.5
3. Power Factor (Typ)		W	Single Phase models: 0.99@230 V AC; 3-Phase models: 0.94@208/380/400/415 V AC (at 100 % load)								
4. Inrush peak current (*3)		A	Single-Phase models: Less than 50 A (only for 3.3 kW models) 3-Phase 208 V models: Less than 50 A 3-Phase 400 V models: Less than 20 A								
5. Efficiency at 208 V and 400 V (*2)		%	82	83	84	84	84	84	86	86	86
6. Efficiency at 170 V and 342 V		%	–	83	–	84	–	84	–	86	–
7. Hold up time	GEN 3.3 kW	ms	10 ms for Single-Phase and 3-Phase 208 V models, 6 ms for 3-Phase 400 V models. Rated output power.								
	GEN 5 kW		5 ms typical								
8. Phase inbalance		%	≤5 %								
9. Leakage current			Less than 3 mA								
2.2 Power Supply Configuration											
1. Parallel Operation			Up to 4 identical units in master/slave mode								
2. Series Operation			Up to 2 identical units with external diodes. 600 V max. to chassis ground								
2.3 Environmental Conditions											
1. Operating temperature			0~50 °C, 100 % load								
2. Storage temperature			–20~85 °C								
3. Operating humidity			20~90 % RH (non-condensing)								
4. Storage humidity			10~95 % RH (non-condensing)								
5. Vibration			MIL-810F, method 514.5. The EUT is fixed to the vibrating surface								
6. Shock			Less than 20 g, half sine, 11 ms. Unit is unpacked								
7. Altitude			Operating: 10,000 ft (3,000 m), Derate output current by 2 % / 100 m above 2,000 m, Alternatively, derate maximum ambient temperature by 1 °C / 100 m above 2,000 m. Non-operating: 40,000 ft (12,000 m).								
8. RoHS Compliance			Complies with the requirements of RoHS directive.								

*1: For cases where conformance to various safety standards (UL, IEC, etc.) is required, to be described as 190~240 V AC (50/60 Hz) for single phase and 3-Phase 208 V models, and 380~415 V AC (50/60 Hz) for 3-Phase 400 V models.

*2: Single-Phase and 3-Phase 208 V models: At 208 V AC input voltage, 3-Phase 400 V: At 380 V AC input voltage. With rated output power.

*3: Not including EMI filter inrush current, less than 0.2 ms.





Specifications Genesys™ 3.3 kW / Genesys™ 5 kW

2.4 EMC	
1. Applicable Standards	
2. ESD	IEC1000-4-2. Air-disch. –8 kV, contact disch. –4 kV
3. Fast transients	IEC1000-4-4. 2 kV
4. Surge immunity	IEC1000-4-5. 1 kV line to line, 2 kV line to ground
5. Conducted immunity	IEC1000-4-6, 3 V
6. Radiated immunity	IEC1000-4-3, 3 V/m
7. Magnetic field immunity	EN61000-4-8, 1 A/m
8. Voltage dips	EN61000-4-11
9. Conducted emission	EN55022A, FCC part 15-A, VCCI-A
10. Radiated emission	EN55022A, FCC part 15-A, VCCI-A
2.5 Safety	
1. Applicable Standards	CE Mark, UL60950-1, EN60950-1 listed. Vout ≤40 V: Output is SELV, IEEE/Isolated analog are SELV. 40 <Vout ≤400 V: Output is hazardous, IEEE/Isolated analog are SELV. 400 <Vout ≤600 V: Output is hazardous, IEEE/Isolated analog are not SELV.
2. Withstand Voltage	Vout ≤40 V models: Input-Outputs (SELV): 4242 V DC 1 min, Input-Ground: 2828 V DC 1 min. 40 <Vout ≤100 V models: Input-Haz. Output: 2600 V DC 1 min, Input-SELV: 4242 V DC 1 min. Hazardous Output.-SELV: 1900 V DC 1min, Hazardous Output-Ground: 1200 V DC 1 min. Input-Ground: 2828 V DC 1 min. 100 <Vout ≤600 V models: Input-Haz. Output: 4000 V DC 1 min, Input-SELV: 4242 V DC 1 min. Hazardous Output.-SELV: 3550 V DC 1 min. Hazardous Output-Ground: 2670 V DC 1 min. Input-Ground: 2828 V DC 1 min.
3. Insulation Resistance	More than 100 M at 25 °C, 70 % RH.
2.6 Mechanical Construction	
1. Cooling	Forced air flow: from front to rear. No ventilation holes at the top or bottom of the chassis; Variable fan speed.
2. Dimensions (W x H x D)	W: 423 mm, H: 88 mm, D: 442.5 mm (excluding connectors, encoders, handles, etc.)
3. Weight	13 kg / 16 kg
4. AC Input connector (with Protective Cover)	Single Phase, 230 V models, Power Combicon PC 6-16/3-GF-10, 16 series, with Strain relief (3.3 kW only). 3-Phase, 208 V & 400 V models, Power Combicon PC 6-16/4-GF-10, 16 series, with Strain relief.
5. Output connectors	8 V to 100 V models: Bus-bars (hole Ø 10.5 mm). 150 V to 600 V models: wire clamp connector, Phoenix P/N: FRONT-4-H-7.62
2.7 Reliability Specs	
1. Warranty	5 years

All specifications subject to change without notice.

Accessories

AC Cords sets (750 W only)

Region	Europe	United Kingdom	Japan	Middle East	North America
Output Power AC Cords	750 W 10 A / 250 V AC L=2 m	750 W 10 A / 250 V AC L=2 m	750 W 13 A / 125 V AC L=2 m	750 W 10 A / 250 V AC L=2 m	750 W 13 A / 125 V AC L=2 m
Wall Plug Power Supply Connector	INT'L 7/VII IEC320-C13	BS1363 IEC320-C13	IEC320-C13	SI-32 IEC320-C13	NEMA 5-15P IEC320-C13
					
Part Number	P/N: GEN/E	P/N: GEN/GB	P/N: GEN/J	P/N: GEN/I	P/N: GEN/U

1. Communication cable

RS-232/RS-485 Cable is used to connect the power supply to the PC Controller

Mode	RS-485	RS-232	RS-232
PC Connector	DB-9F	DB-9F	DB-25F
Communication Cable	Shield Ground L=2 m	Shield Ground L=2 m	Shield Ground L=2 m
Power Supply Connector	EIA/TIA-568A (RJ-45)	EIA/TIA-568A (RJ-45)	EIA/TIA-568A (RJ-45)
Part Number	P/N: GEN/485-9	P/N: GEN/232-9	P/N: GEN/232-25



DB-25 (female connector)

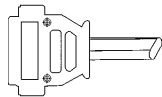

DB-9 (female connector)

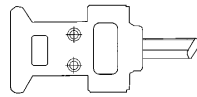

EIA/TIA (RJ-45)

2. Serial link cable (Included with power supply)

Daisy-chain up to 31 Genesys™ power supplies

Mode	Power Supply Connector	Communication Cable	P/N
RS-485	EIA/TIA-568A (RJ-45)	Shield Ground L=50 cm	GEN/RJ45

Rack Mounting applications

The Rack Mounted kit allows the units to be zero stacking for maximum system flexibility and power density without increasing the 1 U height of the units. To install one GENH 750 W one unit or two units side-by-side in a standard 19" rack in 1 U (1.75") height, use option kit **P/N:GENH/RM**



Single unit installation

Single GENH 750 W power supply in a standard 19" rack in 1 U (1.75") height.



Dual unit installation

Two GENH 750 W power supplies side-by-side in a standard 19" rack in 1 U (1.75") height.

Benchtop applications

The benchtop mounted kit allows the units to be zero stacking for maximum system flexibility and power density without increasing the 1 U height of the units. To install a GENH 750 W two units or three units one on top of the other use option kit **P/N:GENH/MO**



Specifications Genesys™ 10 kW / 15 kW

1.0 Model	GEN	7.5-1000	10-1000	12.5-800	20-500	25-400	30-333	40-250	50-200
1. Rated output voltage	V	7.5	10	12.5	20	25	30	40	50
2. Rated output current	A	1000	1000	800	500	400	333	250	200
3. Rated output power	kW	7.5	10.0	10.0	10.0	10.0	10.0	10.0	10.0
4. Efficiency (min) at low line, 100 % Rated Load	%	77					83		
1.0 Model									
1. Rated output voltage	V	N/A	N/A	N/A	N/A	N/A	N/A	N/A	N/A
2. Rated output current	A								
3. Rated output power	kW								
4. Efficiency (min) at low line, 100 % Rated Load	%								
Contact factory for other models									
1.1 Constant Voltage Mode									
1. Max. line regulation (0.1% Vo Max. = <30 V; 0.01 % >30 V)	mV	7.5	10	12.5	20	25	30	4	5
2. Max. load regulation (0.1 % Vo Max. = <30 V; 0.02 % >30 V)	mV	7.5	10	12.5	20	25	30	8	10
3. Ripple RMS 5 Hz~1 MHz c.v (*1)	mV	20	20	20	20	20	20	20	20
4. Output noise p-p (20 MHz) c.v (*1)	mV	60	60	60	60	60	60	60	75
5. Remote sense compensation/wire	V	1	1	1	1	1	1.5	2	3
6. Temp. drift c.v	–	±0.05 % of Vo Rated Over 8 hours, after 30 minute warm up, constant Line, Load & Temperature							
7. Stability c.v	ppm/°C	200 (0.02 % Vo Rated) / °C							
8. Up-prog. response time, 0~Vo max, full-load	ms	100	100	100	100	100	100	100	100
9. Up-prog. response time, 0~Vo max, no load	ms	50	50	50	50	50	50	50	50
10. Transient response time (cv mode) (*2)	ms	less than 3							
1.2 Constant Current Mode									
1. Max. line regulation (0.1 % Io Max. = >333 A; 0.05 % <333 A)	mA	1000	1000	800	500	400	333	125	100
2. Max. load regulation (0.1 % Io Max. = >333 A; 0.075 % <333 A)	mA	1000	1000	800	500	400	333	188	150
1. Max. line regulation (0.1 % Io Max. = >333 A; 0.05 % <333 A)	mA								
2. Max. load regulation (0.1 % Io Max. = >333 A; 0.075 % <333 A)	mA								
3. Ripple RMS 5 Hz~1 MHz c.c	mA	5100	5100	2600	2600	1700	1700	100	80
3. Ripple RMS 5 Hz~1 MHz c.c	mA								
4. Temp. drift c.c	–	±0.05 % of Io Rated Over 8 hours, after 30 minute warm up, constant Line, Load & Temperature							
5. Stability c.c	ppm/°C	300(0.03 % Full Scale) / °C							

*1: Ripple and Noise at Full Rated Voltage & Load at 25 °C, Nominal Line. Per EIJ R9002A

*2: Time for the rated output voltage to recover within 2 % for a load change of 50~100 % or 100~50 % of rated output.

											10 kW	15 kW
60-167	80-125	100-100	125-80	150-66	200-50	250-40	300-33	400-25	500-20	600-17		
60	80	100	125	150	200	250	300	400	500	600	•	
167	125	100	80	66	50	40	33	25	20	17	•	
10.0	10.0	10.0	10.0	9.9	10.0	10.0	9.9	10.0	10.0	10.2	•	
83											•	
60-250	80-187.5	100-150	125-120	150-100	200-75	250-60	300-50	400-37.5	500-30	600-25		
60	80	100	125	150	200	250	300	400	500	600		•
250	187.5	150	120	100	75	60	50	37.5	30	25		•
15.0	15.0	15.0	15.0	15.0	15.0	15.0	15.0	15.0	15.0	15.0		
88	88											•
Contact factory for other models												
6	8	10	12.5	15	20	25	30	40	50	60	•	•
12	16	20	25	30	40	50	60	80	100	120	•	•
20	25	25	25	25	35	35	60	60	60	60	•	•
75	100	100	125	150	175	200	200	300	350	350	•	•
3	4	5	5	5	5	5	5	5	5	5	•	•
±0.05 % of Vo Rated Over 8 hours, after 30 minute warm up, constant Line, Load & Temperature											•	•
200 (0.02 % Vo Rated) / °C											•	•
100	100	100	100	100	100	100	100	100	100	100	•	•
50	50	50	50	50	50	50	50	50	50	50	•	•
less than 3											•	•
83.5	62.5	50	40	33	25	20	17	13	10	9	•	
125	94	75	60	50	38	30	25	19	15	13	•	
125	94	75	60	50	38	30	25	19	15	13		•
188	141	113	90	75	56	45	38	28	23	19		•
67	50	40	32	26	20	16	13	10	8	7	•	
100	100	100	50	50	20	20	20	10	10	10		•
±0.05 % of Io Rated Over 8 hours, after 30 minute warm up, constant Line, Load & Temperature											•	•
300 (0.03 % Full Scale) / °C											•	•
											Sequel ▶	

Specifications Genesys™ 10 kW / 15 kW

1.3 Protective Functions	GEN	7.5-1000	10-1000	12.5-800	20-500	25-400	30-333	40-250	50-200
1. OCP	%	0~100							
2. OCP type	–	Constant current							
3. Foldback protection	–	Output shut-down, manual reset by front panel OUT button							
4. Foldback response time	s	Less than 1							
5. OVP type	–	Inverter shut-down, manual reset by On/Off recycle or by OUT button							
6. OVP programming accuracy	%	5 % Full Scale							
7. OVP trip point	V	0.05 to (1.02 – 1.05) x Rated Output Voltage							
8. OVP response time	ms	Less than 10 ms for Output to begin to drop							
9. Max. OVP reset time	s	7 from Turn On							
10. Over temperature protection	–	Shut down if internal temperature exceeds safe operating levels (Latched in Safe Mode / Unlatched in Auto Mode)							
11. Phase Loss Protection	–	Yes							
1.4 Remote Analog Controls & Signals									
1. Vout voltage programming	0~100 %, 0~5 V or 0~10 V, user selectable. Accuracy & Linearity ± 1 % of Rated Vo.								
2. Iout voltage programming	0~100 %, 0~5 V or 0~10 V, user selectable. Accuracy & Linearity ± 1 % of Rated Io.								
3. Vout resistor programming	0~100 %, 0~5/10 k full scale, user selectable. Accuracy & Linearity ± 1 % of Rated Vo.								
4. Iout resistor programming	0~100 %, 0~5/10 k full scale, user selectable. Accuracy & Linearity ± 1 % of Rated Io.								
5. On/Off control (rear panel)	By Voltage: 0.6 V = Disable, 2 – 15 V = enable (default) or dry contact, user selectable logic								
6. Output current monitor	0~5 V or 0~10 V, accuracy: 1 %, user selectable								
7. Output voltage monitor	0~5 V or 0~10 V, accuracy: 1 %, user selectable								
8. Power supply OK signal	Yes. TTL high-OK, 0V (500 Ω impedance)-Fail								
9. CV/CC signal	CV: TTL high (4~5 V) source: 10 mA, CC: TTL low (0~0.4 V): 10 mA								
10. Enable/Disable	Dry contact. Open: Off, Short: On. Max. voltage at Enable / Disable Contacts 6 V								
11. Remote/Local selection	Selects Remote or Local operation by Voltage: 0~0.6 V / 2~15 V, <0.6 V = Local 2 – 15 V = Remote								
12. Remote/Local signal	Signals operating mode in use								
1.5 Front Panel									
1. Control functions	Vout/Iout manual adjust by separate encoders, Fine and Coarse selectable. OVP/UVL manual adjust by Voltage Adjust encoder, Front Panel Lock/Unlock Address selection by Voltage Adjust encoder. No of addresses:31 AC On/Off, Output On/Off, Restart Modes (Auto/Safe), Foldback Control (CV to CC), Go to Local RS232/485 and IEEE488.2 selection by IEEE enable switch and DIP switch Baud rate selection by Current adjust encoder Parallel Master Slave: Hx, where x = Slaves 0 up to four								
2. Display	Vout: 4 Digits, Accuracy: 0.5 % ± 1 Count Iout: 4 Digits, Accuracy: 0.5 % ± 1 Count Voltmeter is user selectable to read either local voltage (at power supply) or remote voltage (at the load)								
3. Indications	ADDR., OVP/UVL, V/A, FOLD, REM./LOCAL, OUT ON/OFF, LFP/UFP, CC/CV: GREEN LED's. ALRM (OVP, OTP, FOLD, AC FAIL): RED LED								
1.6 Digital Programming & Readback									
1. Vout programming accuracy	± 0.5 % of rated output voltage								
2. Iout programming accuracy	± 0.5 % of rated output current for units with $I_o < 187.5$; ± 0.7 % of rated output current for $I_o \leq 187.5$								
3. Vout programming resolution	0.02 % of full scale								
4. Iout programming resolution	0.04 % of full scale								
5. Vout readback accuracy	0.1 % + 0.2 % of rated output voltage								
6. Iout readback accuracy	0.1 % + 0.4 % of rated output current								
7. Vout readback resolution	0.02 % of full scale								
8. Iout readback resolution	0.02 % of full scale								
9. OV Response time	20 ms maximum between output V exceeding IEEE Limit and supply inhibit turning on								
10. Other Functions	Set Over-Voltage Limit, Set Local/Remote								

											10 kW	15 kW
60-167	80-125	100-100	125-80	150-66	200-50	250-40	300-33	400-25	500-20	600-17		
0~100											•	•
Constant current											•	•
Output shut-down, manual reset by front panel OUT button											•	•
Less than 1											•	•
Inverter shut-down, manual reset by On/Off recycle or by OUT button											•	•
5 % Full Scale											•	•
0.05 to (1.02 – 1.05) x Rated Output Voltage											•	•
Less than 10 ms for Output to begin to drop											•	•
7 from Turn On											•	•
Shut down if internal temperature exceeds safe operating levels (Latched in Safe Mode / Unlatched in Auto Mode)											•	•
Yes											•	•
0~100 %, 0~5 V or 0~10 V, user selectable. Accuracy & Linearity ± 1 % of Rated Vo.											•	•
0~100 %, 0~5 V or 0~10 V, user selectable. Accuracy & Linearity ± 1 % of Rated Io.											•	•
0~100 %, 0~5/10 k full scale, user selectable. Accuracy & Linearity ± 1 % of Rated Vo.											•	•
0~100 %, 0~5/10 k full scale, user selectable. Accuracy & Linearity ± 1 % of Rated Io.											•	•
By Voltage: 0.6 V = Disable, 2 – 15 V = enable (default) or dry contact, user selectable logic											•	•
0~5 V or 0~10 V, accuracy: 1 %, user selectable											•	•
0~5 V or 0~10 V, accuracy: 1 %, user selectable											•	•
Yes. TTL high-OK, 0 V (500 Ω impedance)-Fail											•	•
CV: TTL high (4~5 V) source: 10 mA, CC: TTL low (0~0.4 V): 10 mA											•	•
Dry contact. Open: Off, Short: On. Max. voltage at Enable / Disable Contacts 6 V											•	•
Selects Remote or Local operation by Voltage: 0~0.6 V / 2~15 V, <0.6 V = Local 2 – 15 V = Remote											•	•
Signals operating mode in use											•	•
Vout/Iout manual adjust by separate encoders, Fine and Coarse selectable.											•	•
OVP/UVL manual adjust by Voltage Adjust encoder, Front Panel Lock/Unlock											•	•
Address selection by Voltage Adjust encoder. No of addresses: 31											•	•
AC On/Off, Output On/Off, Restart Modes (Auto/Safe), Foldback Control (CV to CC), Go to Local											•	•
RS232/485 and IEEE488.2 selection by IEEE enable switch and DIP switch											•	•
Baud rate selection by Current adjust encoder											•	•
Parallel Master Slave: Hx, where x = Slaves 0 up to four											•	•
Vout: 4 Digits, Accuracy: 0.5 % ± 1 Count											•	•
Iout: 4 Digits, Accuracy: 0.5 % ± 1 Count											•	•
Voltmeter is user selectable to read either local voltage (at power supply) or remote voltage (at the load)											•	•
ADDR., OVP/UVL, V/A, FOLD, REM./LOCAL, OUT ON/OFF, LFP/UFP, CC/CV: GREEN LED's. ALRM (OVP, OTP, FOLD, AC FAIL): RED LED											•	•
± 0.5 % of rated output voltage											•	•
± 0.5 % of rated output current for units with $I_o < 187.5$; ± 0.7 % of rated output current for $I_o \leq 187.5$											•	•
0.02 % of full scale											•	•
0.04 % of full scale											•	•
0.1 % + 0.2 % of rated output voltage											•	•
0.1 % + 0.4 % of rated output current											•	•
0.02 % of full scale											•	•
0.02 % of full scale											•	•
20 ms maximum between output V exceeding IEEE Limit and supply inhibit turning on											•	•
Set Over-Voltage Limit, Set Local/Remote											•	•

General Specifications Genesys™ 10 kW / 15 kW

2.1 Input Characteristics	
1. Input voltage / freq. (range)	208 V AC (180~253); 400 V AC (360/440); 480 V AC (432~528), all 47 – 63 Hz
2. No. of phases	3 Phases (Wye or Delta) 4 wire total (3 Phase and 1 protective earth ground)
3. Dropout voltage	180 / 360 / 432 V
4. Input current 180 / 360 / 432 V AC	10 kW – 45 / 23 / 20 A; 15 kW – 64 / 32 / 27 A. All at full rated output power.
5. Inrush current	Not to exceed full rated Input current. See Para 2.4
6. Power Factor	0.88 Passive
7. Leakage current	3.5 mA (EN60950) max.
8. Input Protection	208 V AC Circuit Breaker; 400 V AC, 480 V AC – Line Fuse
9. Input Overvoltage Protection	Unit shall not be damaged by line overvoltage with max. duration of 100 μ s. Up to 120 % of nominal AC input voltage.
10. Phase Imbalance	\leq 5 % on Three Phase Input
2.2 Power Supply Configuration	
1. Parallel Operation	Up to four (4) identical units may be connected in Master/Slave Mode with 'Single' wire connection. In advanced parallel feature, the current of Master unit, multiplied by number of units connected in parallel, is made available on digital interface and displayed on front panel of Master unit. Remote analog current monitor of the Master is scaled to output current of the Master unit (only).
2. Series Operation	Possible (with external diodes), up to 2 identical units with total output not to exceed \pm 600 V from chassis ground.
2.3 Environmental Conditions	
1. Operating temperature	0~50 °C, 100 % load
2. Storage temperature	-20~70 °C
3. Operating humidity	20~80 % RH (non-condensing)
4. Storage humidity	10~90 % RH (non-condensing)
5. Vibration & Shock (208 / 400 V AC)	ASTM D4169, Standard practice for performance testing of shipping containers and systems. Shipping unit: single package. Assurance level: Level II. Acceptance criteria: Criterion 1 – No product damage. Criterion 2 – Packaging is intact. Distribution cycle: 12 – Air (intercity) and motor freight (local), unitized is used
6. Altitude	Operating: 50 °C up to 7,500 ft (2,500 m), 45 °C from 7,501 to 10,000 ft (2,501 – 3,000 m) Non operating 40,000 ft (12,000 m)
7. Audible Noise	65 dBA at full load, measured 1 m from front panel

2.4 EMC	
208 V input models	CE Mark
1. ESD	EN61000-4-2 (IEC 801-2) air-disch. ± 8 kV, contact disch. ± 4 kV
2. Fast transients	EN61000-4-4 (IEC 1000-4-3)
3. Surge immunity	EN61000-4-5 (IEC 1000-4-5)
4. Conducted immunity	EN61000-4-6 (IEC 1000-4-6)
5. Radiated immunity	EN61000-4-3 (IEC 1000-4-3)
6. Power frequency magnetic field	EN61000-4-8
7. Conducted emission	EN55011A, FCC part 15J-A
8. Radiated emission	EN55011A, FCC part 15J-A
400 V input models	CE Mark
1. ESD	EN61000-4-2 (IEC 801-2) Air-disch. ± 8 kV, contact disch. ± 4 kV
2. Fast transients	EN61000-4-4 (IEC 1000-4-3)
3. Surge immunity	EN61000-4-5 (IEC 1000-4-5)
4. Conducted immunity	EN61000-4-6 (IEC 1000-4-6)
5. Radiated immunity	EN61000-4-3 (IEC 1000-4-3)
6. Power frequency magnetic field	EN61000-4-8
7. Voltage dips, short interruptions and voltage variations immunity tests (400 V AC only)	IEC 61000-4-11
8. Conducted emission	EN55011A, FCC part 15J-A
9. Radiated emission	EN55011A, FCC part 15J-A
2.5 Safety	
1. Applicable Standards	UL/CUL 60950-1, EN60950-1 recognized. All outputs are hazardous. (Units with IEMD or ISOL option are recognized up to 400 V output). CE Mark 208 & 400 V AC inputs only (CB scheme).
2. Insulation Resistance	100 M at 500 V DC
2.6 Mechanical Construction	
1. Cooling	Fan driven, airflow from front to rear. Supplemental vents on side that shall not be blocked. EIA rack mounting, stackable. "Zero stackable" top and bottom. Slides or suitable rear support required.
2. Dimensions (WxHxD)	W:19" rack, H: 3 U – 5.22" (133 mm), D: 22.2" (564 mm) without connectors.
3. Weight	43 kg / 97 lbs
4. Types of connectors	1. Input: Threaded studs and terminal cover. Stain relief optional. 2. Output: Up to and including 300 V models: bus-bars. Greater than 300 V models: threaded stud terminals. 3. Analog programming: DB25, plastic connector, AMP, 747461-5, female on power supply, male on mating connector 747321. Standard 25 pin D connector.
5. Mounting method	Standard 19" rack mount, provision for standard slides. Slide/rear support is required; do not mount by F/P only.
6. Output ground connection	M5 Stud
2.7 Reliability Specs	
1. Warranty	5 years

Genesys™ power parallel and series configurations

Parallel operation – Master/Slave

Active current sharing allows up to four identical units to be connected in an auto-parallel configuration for four times the output power.

In Advanced Parallel Master/Slave Mode, total current is programmed and reported by the Master, up to four supplies act as one.

Series operation

Up to two units may be connected in series to increase the output voltage or to provide bipolar output. (Max 600 V to Chassis Ground).

Remote programming

via RS-232 and RS-485 Interface

Standard Serial Interface allows daisy-chain control of up to 31 power supplies on the same communication bus with built-in RS-232 & RS-485 Interface.

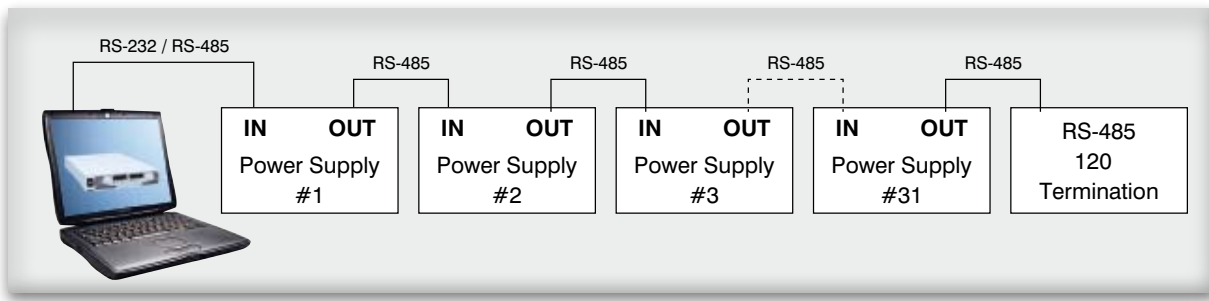

Multi power supplies RS-232 / RS-485 connection

LAN interface

LXI compliant to class C

- Meets all **LXI-C** Requirements
- Address Viewable on Front Panel
- Fixed and Dynamic Addressing
- Compatible with most standard Networks

- VISA & SCPI compatible
- LAN Fault Indicators
- Auto-detects LAN Cross-over Cable
- Fast Start-up

P/N: LAN

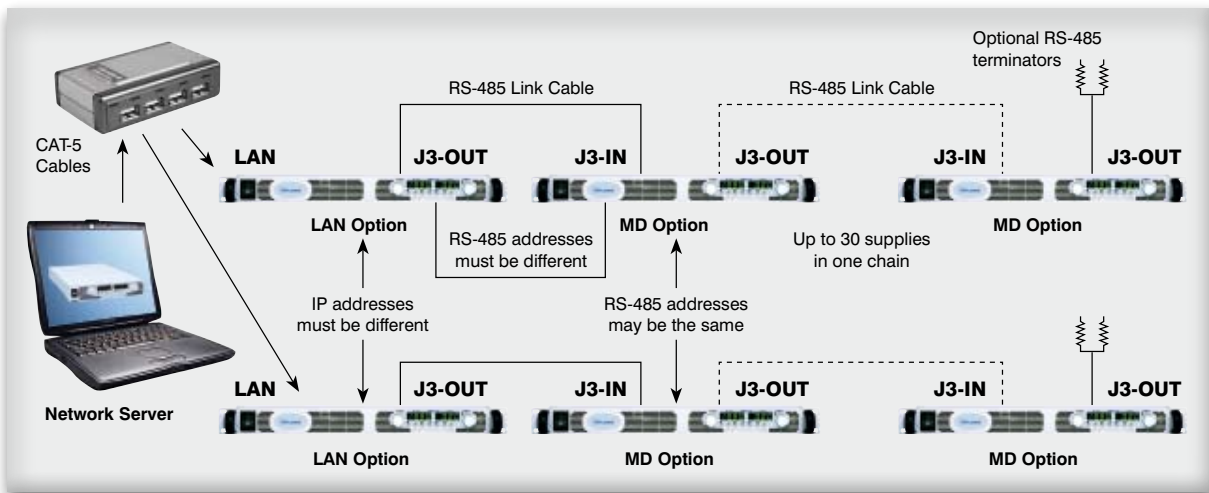

Configuring a Multi-drop system of supplies

Programming options (Factory installed)

Digital Programming via IEEE Interface

- IEEE 488.2 SCPI compliant
- Program Voltage
- Program Current
- Measure Voltage
- Measure Current
- Over Voltage setting and shutdown
- Current Foldback shutdown
- Error and Status Messages
- Multi-Drop
 - Allows IEEE Master to control up to 31 slaves over RS-485 daisy-chain
 - Only the Master needs be equipped with IEEE Interface

P/N: IEEE

Isolated Analog Programming

Four channels to Program and Monitor Voltage and Current. Isolation allows operation with floating references in harsh electrical environments. Choose between programming with Voltage or Current. Connection via removable terminal block: Phoenix MC1,5/8-ST-3.81.

Voltage Programming, user-selectable

0 – 5 V or 0 – 10 V signal.

P/N: IS510

- Power supply Voltage and Current Programming Accuracy $\pm 1\%$
- Power supply Voltage and Current Monitoring Accuracy $\pm 1.5\%$

Current Programming

with 4 – 20 mA signal.

P/N: IS420

- Power supply Voltage and Current Programming Accuracy $\pm 1\%$
- Power supply Voltage and Current Monitoring Accuracy $\pm 1.5\%$

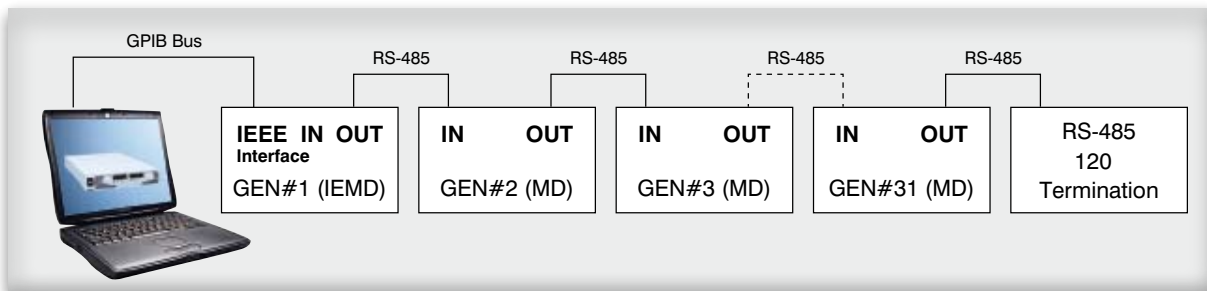
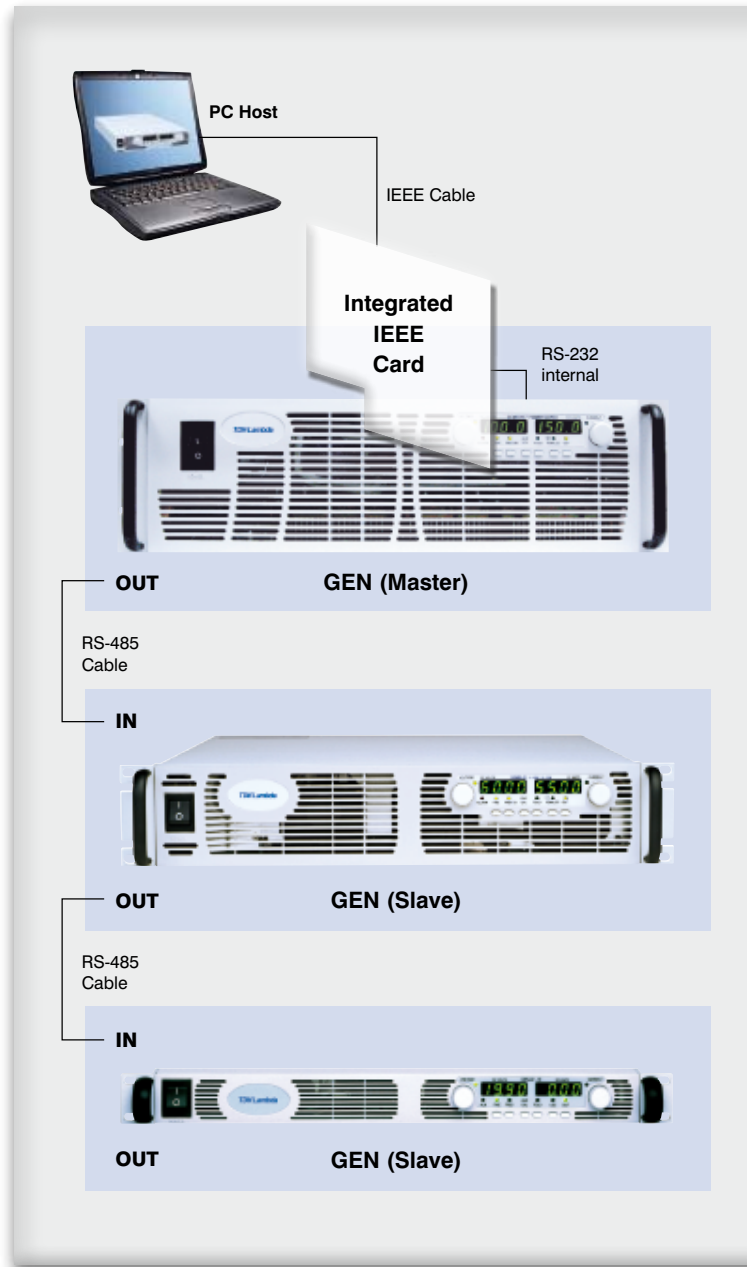

Multi-drop power supplies configuration

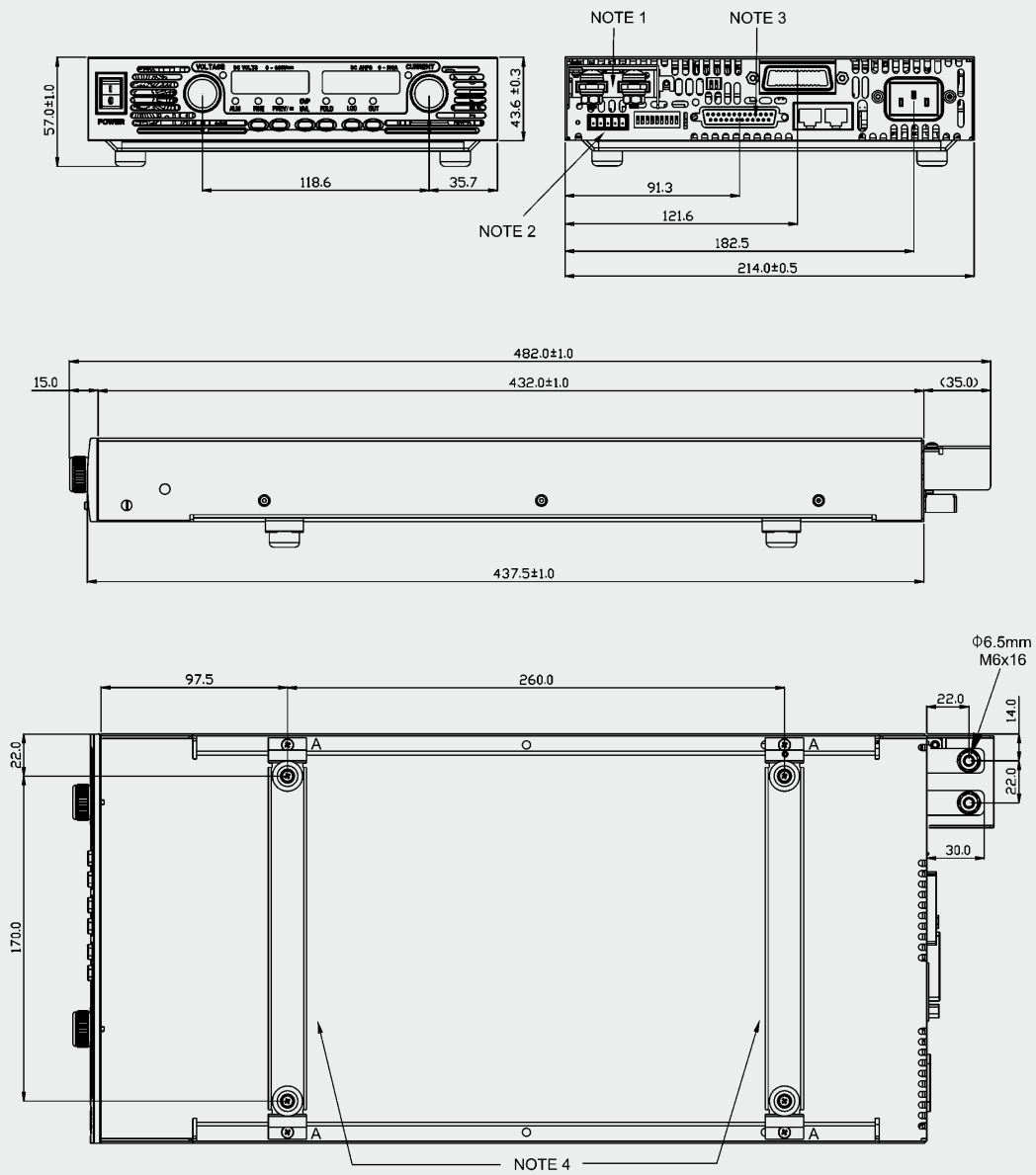

NOTE 1

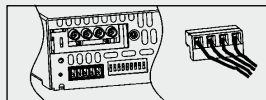

1. Bus-bars 6 V to 60 V models
Connector 80 V to 600 V model
Header Phoenix P/N: GIC 2.5/4-G-7.62
Mating plug Phoenix P/N: GIC 2.5/4-ST-7.62
2. Mating plug Phoenix P/N: MC1.5/5-ST-3.81
3. Mating plug AMPP/N: 745211-2
Mating plugs supplied with power supply.
4. Mounting benchtop assembly x 2 (removable)
Screws: 4 x M 3 x 8 marked "A".

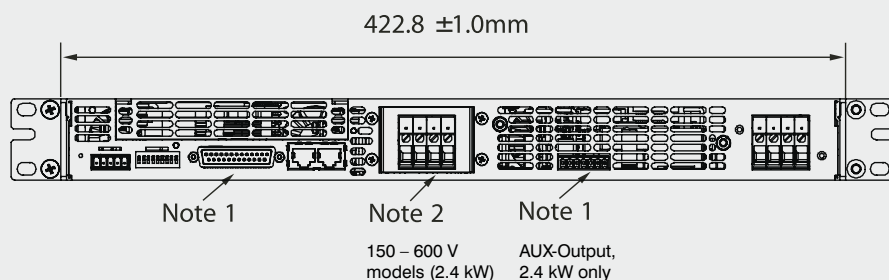
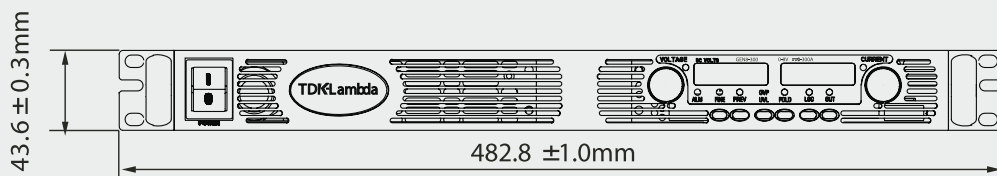

Bus-Bar Detail
8 V to 100 V Models

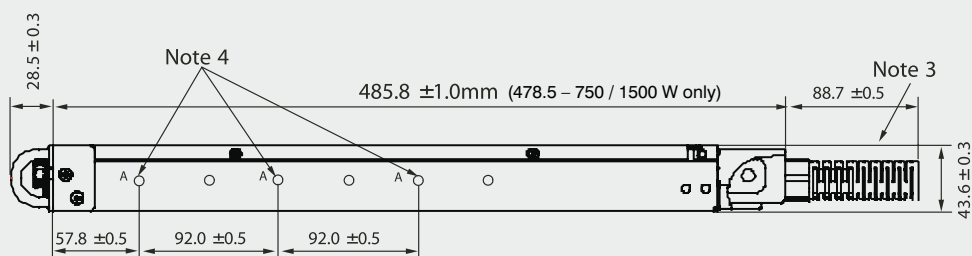
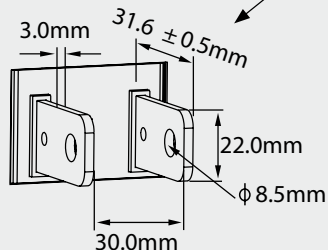

1. Mating plug supplied with power supply.
2. DC output:
for 2400 W units (shown): Bus-bars for 8 V to 100 V models
wire clamp terminal for 150 V to 600 V models.
750 W / 1500 W units: Bus-bars for 6 V to 60 V models
wire clamp terminal for 80 V to 600 V models.
3. AC cable strain relief supplied with power supply.
4. Chassis slides mounting holes #10-32 marked "A".
GENERAL DEVICES P/N: CC3001-00-S160 or equivalent.

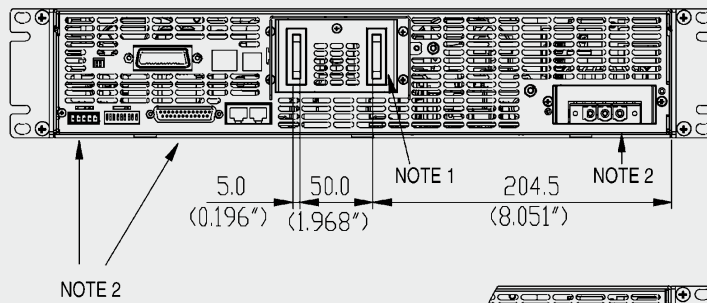
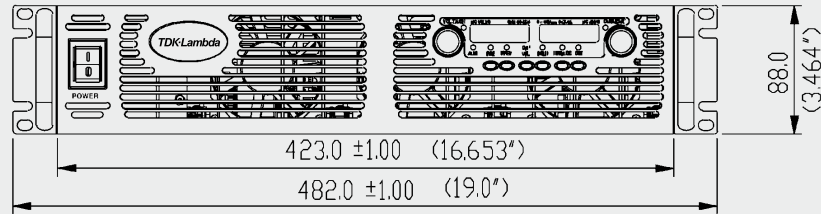

NOTE 2

3 Phase Input Connector

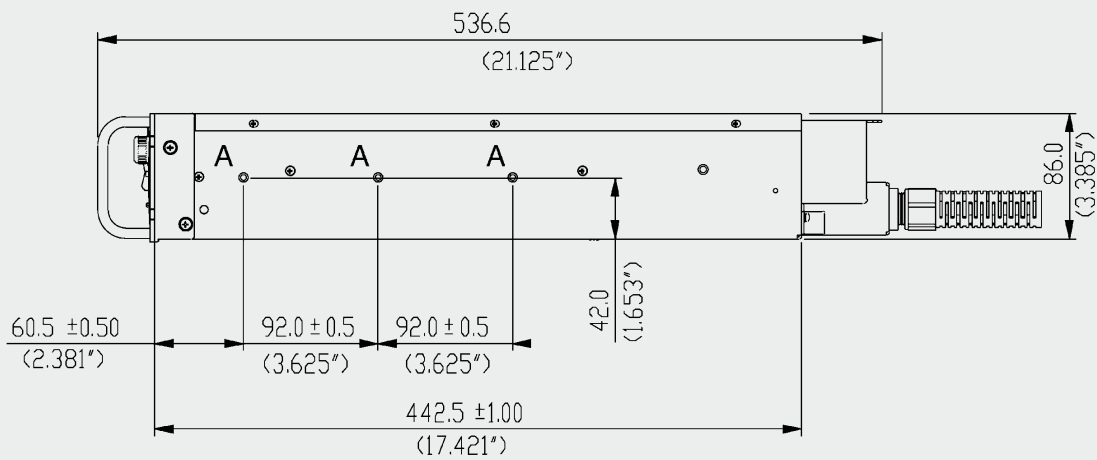
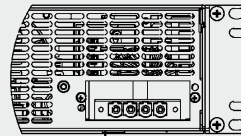

1. Bus bars for 8 V to 100 V models (shown)
Wire clamp connector for 150 V to 600 V models
2. Plug connectors included with the power supply
3. Chassis slides mounting holes #10-32 marked "A"
GENERAL DEVICES P/N: C-300-S-116 or equivalent

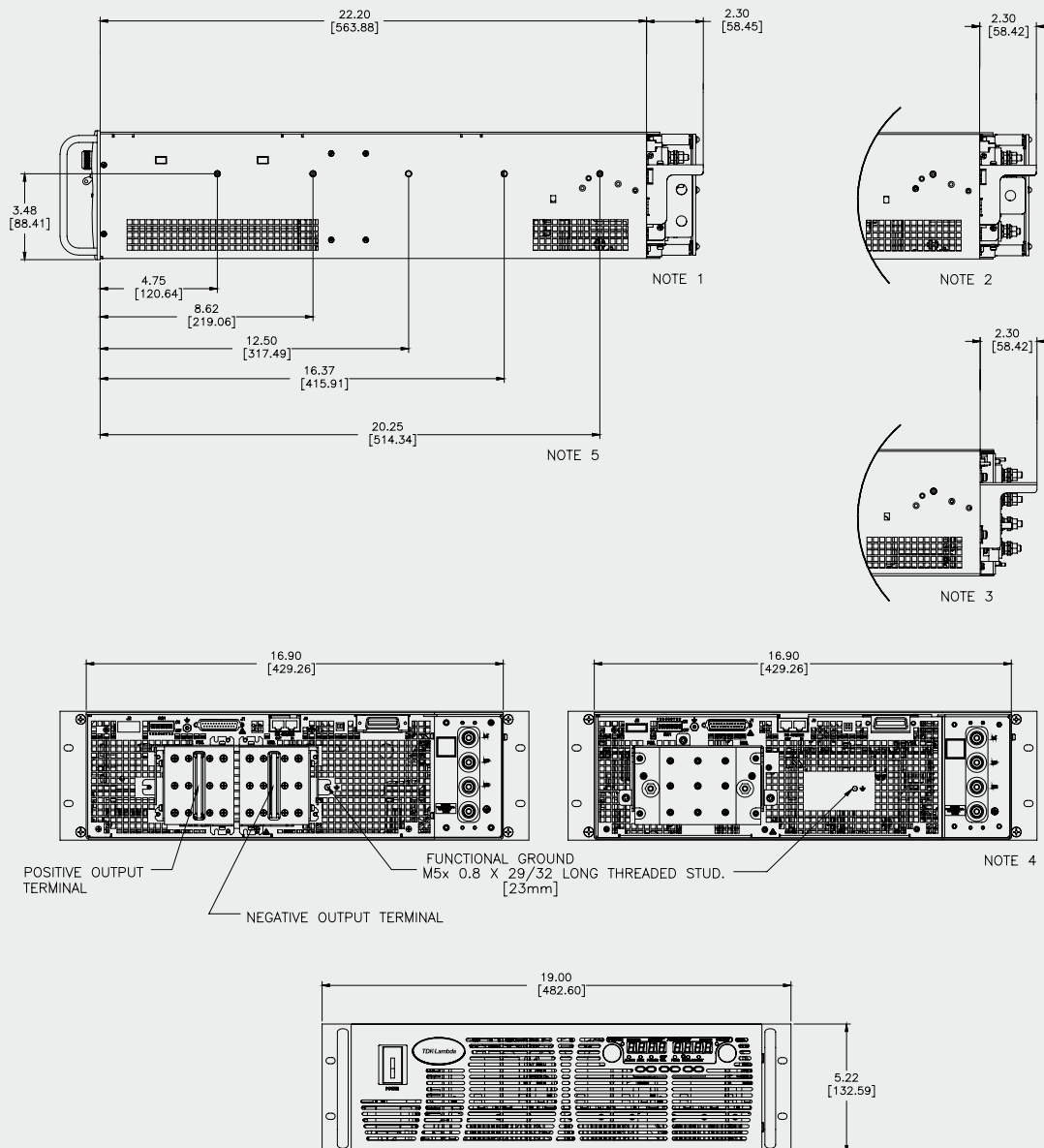

1. For models up to 80 V DC Output two holes 0.42" Dia (10.72 mm)
2. For models 100 – 300 V DC Output one hole 0.42" Dia (10.72 mm)
3. For models above 300 V Output threaded stud terminal
4. Input Terminals M6x1 (3 + GND)
5. Mounting for Slide Mounts (not included).
 Recommend General Devices, Chassis Trak P/N: C230-S-122.
 Secure with pan head screw M5x0.8-8 mm long MAX.

Zero-up

200 W / 400 W / 800 W

Built-in RS-232 and RS-485 Interface with GPIB optional



- Constant Voltage / Constant Current
- Built-in RS-232 & RS-485 Interface
- An embedded Microprocessor controller
- Digital Encoder Knob
- Software Calibration
- Last Setting Memory
- Parallel Operation (Master/Slave) Active Current Sharing
- External Voltage or Resistance Programming
- Voltage up to 120 V, Current up to 132 A
- Active Power Factor Correction: 99 %
- 85~265 V AC Universal Input Voltage
- 19" Rack Mounted ATE and OEM
- Worldwide Safety Agency Approvals
- CE Mark for LVD and EMC Regulation



Product Line up

Model	Output Voltage V DC	Output Current (A)	Output Power (W)
ZUP6-33	0 ~ 6 V DC	0 ~ 33	198
ZUP6-66		0 ~ 66	396
ZUP6-132		0 ~ 132	792
ZUP10-20	0 ~ 10 V DC	0 ~ 20	200
ZUP10-40		0 ~ 40	400
ZUP10-80		0 ~ 80	800
ZUP20-10	0 ~ 20 V DC	0 ~ 10	200
ZUP20-20		0 ~ 20	400
ZUP20-40		0 ~ 40	800

Model	Output Voltage V DC	Output Current (A)	Output Power (W)
ZUP36-6	0 ~ 36 V DC	0 ~ 6	216
ZUP36-12		0 ~ 12	432
ZUP36-24		0 ~ 24	864
ZUP60-3.5	0 ~ 60 V DC	0 ~ 24	200
ZUP60-7		0 ~ 7	420
ZUP60-14		0 ~ 14	840
ZUP80-2.5	0 ~ 80 V DC	0 ~ 2.5	200
ZUP80-5		0 ~ 5	400
ZUP120-1.8	0 ~ 120 V DC	0 ~ 1.8	216
ZUP120-3.6		0 ~ 3.6	432

Front Panel

1. Digital Voltmeter
2. Digital Amperemeter
3. Constant Voltage Mode Indicator
4. Constant Current Mode Indicator
5. Voltage/Current, OVP/UVP, Address Adjust
6. Alarm (OVP, OTP, FOLD)
7. Output ON/OFF Control
8. Local/Remote Select
9. Foldback Protection Control
10. AC Power Switch
11. Voltage/Current Mode Control
12. Overvoltage/Undervoltage Setting
13. Address Setting

Rear Panel

14. IEC320 AC Input Connectors
15. Remote IN Programming via RS-232/RS-485
16. Remote OUT Via RS-485 Communications
Chaining Power Supplies to Serial Communication Bus
17. External Analog Programming Control Connector
18. Output Bus Bars (6 V to 60 V) model shown.
80 V to 120 V models PHOENIX: PSC Plug Connectors
19. Ground Thread

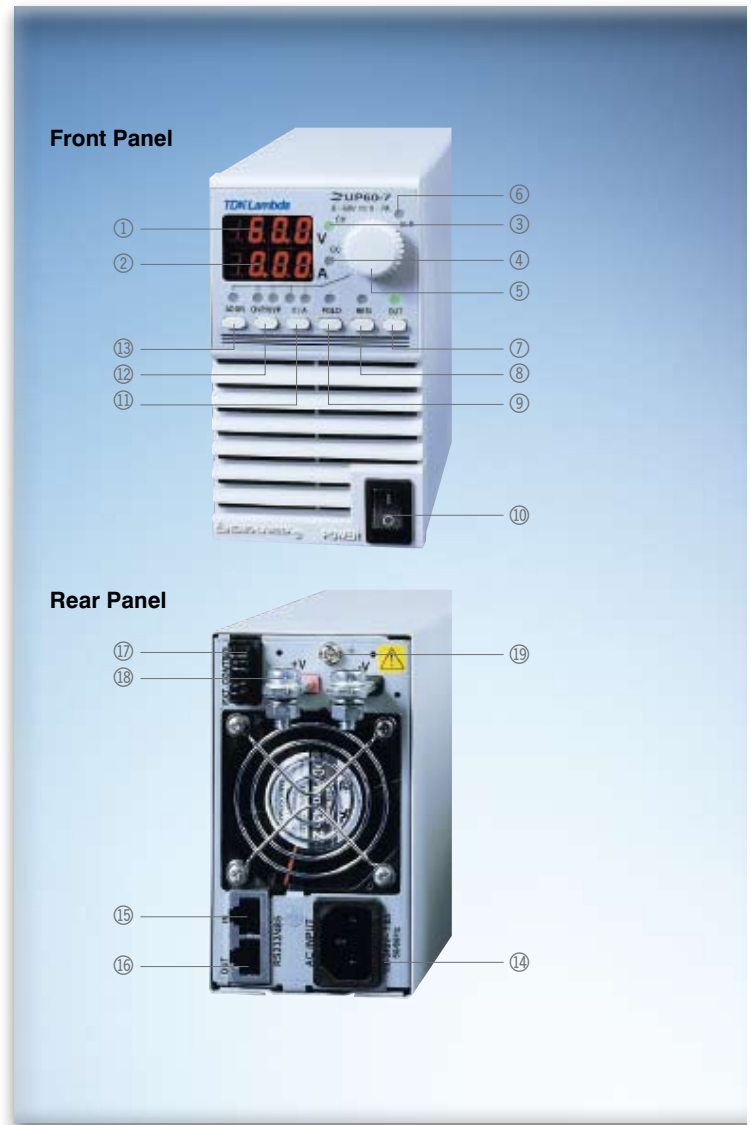

How to order

Power Supply Identification / Accessories

ZUP	36	- 12	/		
Series Name	Output Voltage (0 ~ 36 V)	Output Current (0 ~ 12 A)	Front Panel L. Output Jack BLANK: Standard	AC Cable E. Europe U. USA O. Unterminated I: SI 32 std. BLANK: None	Serial Link Cable W. Cable included BLANK: None

Specifications ZUP Series

Model			ZUP6-33	ZUP6-66	ZUP6-132	
Output voltage (*1)		V	0-6	0-6	0-6	
Output current (*2)		A	0-33	0-66	0-132	
Rated output power		W	198	396	792	
Constant voltage	Load regulation	–	0.005 % +2 mV, from No load to Full load, constant input voltage			
	Line regulation	–	0.005 % +1 mV, from 85-132 V AC or 170-265 V AC, constant load			
	RMS ripple (5 Hz–1 MHz Bandwidth)	mV	5	5	8	
	Ripple (pk to pk) (20 MHz Bandwidth)	mV	50	50	100	
	Recovery time (*3)	ms	1	1	1	
	Temperature coefficient	–	30 ppm/°C from rated voltage following 30-minute warm-up.			
	Temperature drift	–	0.01 % +2 mV Change in output, over 8-hour interval under constant line, load and ambient temperature following 30-minute warm-up			
	UP Programming response time (*4)	ms	50	50	60	
	Down programming	Full load	ms	50	50	50
	Response time	No load	ms	250	350	
Constant current	Load regulation (*5)	–	0.01 % +5 mA	0.01 % +5 mA	0.07 % +10 mA	
	Line regulation (*6)	–	0.01 % +2 mA	0.01 % +2 mA	0.01 % +5 mA	
	RMS ripple (5 Hz–1 MHz Bandwidth)	mA	50	100	200	
	Temperature coefficient	–	100 ppm/ °C from rated current following 30-minute warm-up.			
	Temperature drift (*8)	–	0.02 % +5 mA	0.02 % +5 mA	0.05 % +10 mA	
Programming (*9)	Resolution	–	Better than 0.028 % of rated output voltage			
	Voltage Accuracy	–	0.02 % +5 mV	0.02 % +5 mV	0.02 % +5 mV	
	Resolution	–	Better than 0.03 % of rated output current			
	Current Accuracy	–	0.4 % +40 mA			
Overvoltage Protection (*10)		V	0–7.5	0–7.5	0–7.5	
Hold-up time		–	20 ms @ 100 V/200 V AC, rated output voltage and output current.			
Display	Voltage	–	3 digits (6 V; 20 V; 36 V; 60 V; 80 V); 3.5 digits (10 V; 120 V) accuracy: 0.2 % ±2 digits			
	Current	–	3.5 digits (132 A); All others 3 digits, accuracy: 0.5 % ±3 digits			
	Status	–	CV/CC, Alarm, Fold, Local/Remote, On/Off			
Output protections		–	Over Voltage, Over Temperature, Foldback.			
Input	Input voltage (*11)	–	85–265 V AC Continuous, 47–63 Hz			
	Input current (*12)	A	3.0/1.5	5.6/2.7	11.2/5.4	
	Inrush current (100/200 V)	A	15/30 (*7)	15	30	
	Efficiency (*12)	%	69/72	74/77	74/77	
	Input current harmonics	–	Complies with EN61000-3-2, Class A			
	Power factor (TYP)	–	0.99 at 100/200 V AC, 100 % load.			
Environment	Operating temperature	–	0 to 50 °C ; 100 % Load			
	Operating humidity	–	30 – 90 % RH (No dewdrop).			
	Storage temperature	–	–20 to 70 °C			
	Operating humidity	–	10 – 95 % RH (No dewdrop).			
Mechanical	Vibration	–	10 – 55 Hz, Amplitude (sweep 1 min) 2 g, X, Y, Z, When mounted with mounting screws.			
	Shock	–	Less than 20 g			
	Weight	kg	2.9	3.2	5.8	
	Size (WxHxD)	mm	200 W and 400 W units: 70 x 124 x 350. 800 W units: 140 X 124 X 350 (Refer to outline drawing)			

*1, *2, *3, *4, *5, *6, *8, *11, *12: annotation on page 52.

ZUP10-20	ZUP10-40	ZUP10-80	ZUP20-10	ZUP20-20	ZUP20-40	ZUP36-6
0-10	0-10	0-10	0-20	0-20	0-20	0-36
0-20	0-40	0-80	0-10	0-20	0-40	0-6
200	400	800	200	400	800	216
5	5	8	5	5	5	5
50	50	90	50	50	80	50
1	0.5	0.5	0.5	0.2	0.2	0.2
50	50	60	50	50	60	50
50	50	50	50	50	50	50
0.01 % +5 mA	0.01 % +5 mA	0.07 % +10 mA	0.01 % +5 mA	0.01 % +5 mA	0.07 % +10 mA	0.01 % +5 mA
0.01 % +2 mA	0.01 % +2 mA	0.01 % +5 mA	0.01 % +2 mA	0.01 % +2 mA	0.01 % +5 mA	0.01 % +2 mA
25	50	100	15	30	60	7.5
0.02 % +5 mA	0.02 % +5 mA	0.05 % +10 mA	0.02 % +5 mA	0.02 % +5 mA	0.02 % +10 mA	0.02 % +5 mA
0.02 % +8 mV	0.02 % +8 mV	0.02 % +8 mV	0.02 % +12 mV	0.02 % +12 mV	0.02 % +12 mV	0.02 % +20 mV
0-13	0-13	0-13	0-24	0-24	0-24	0-40
2.9/1.4	5.6/2.7	11.2/5.4	2.9/1.4	5.6/2.7	11.2/5.4	2.9/1.4
15/30 (*7)	15	30	15/30	15	30	15/30 (*7)
73/77	79/82	77/81	74/78	79/83	79/82	76/80
2.9	3.2	5.8	2.9	3.2	5.8	2.9

Sequel ►

Specifications ZUP Series

Model		ZUP6-33	ZUP6-66	ZUP6-132
External control Functions	Output on/off	–	By TTL Signal or Dry Contact (Refer to instruction manual)	
	Output good	–	Open collector (Refer to instruction manual).	
	Output voltage programming	–	By Voltage (0–4 V) or by Resistance (0–4 K) (Refer to instruction manual).	
	Output current programming	–	By Voltage (0–4 V) or by Resistance (0–4 K) (Refer to instruction manual).	
	Remote sensing	–	Maximum 0.5 V drop on each load wire for model up to 60 V and 2 V for the 80 V, 120 V models	
	Communication interface	–	RS232 and RS485 Built-in, IEEE488 Optional.	
Approvals	Safety standards	–	UL3111-1, EN61010-1	
	EMC standards	–	EN61326-1, IEC 61326-1, FCC part 15 (class A)	
Conducted EMI		–	EN55022-B, FCC-B, VCCI-2	
Radiated EMI		–	EN55022-A, FCC-A, VCCI-1	
Series operation		–	Up to 2 units (Refer to instruction manual).	
Parallel operation		–	Master/Slave method; up to 5 units (Refer to instruction manual)	
Cooling		–	Forced air by blower fan (Blower fan is mounted within unit)	
Withstand options		–	Input – Chassis...2.0 kV AC 1 min, Input – Output...3.0 kV AC 1 min, Output – GND...500 V AC 1 min.	
Isolation resistance		–	More than 100 M at 25 °C and 70 % R.H.	

Model		ZUP36-12	ZUP36-24	ZUP60-3.5		
Output voltage (*1)		V	0-36	0-36	0-60	
Output current (*2)		A	0-12	0-24	0-3.5	
Rated output power		W	432	864	210	
Constant voltage	Load regulation	–	0.005 %+2 mV, from No load to Full load, constant input voltage			
	Line regulation	–	0.005 %+1 mV, from 85-132 V AC or 170-265 V AC, constant load			
Constant current	RMS ripple (5 Hz–1 MHz Bandwidth)	mV	5	5	5	
	Ripple (Pk-Pk) (20 MHz Bandwidth)	mV	50	70	50	
	Recovery time (*3)	ms	0.2	0.2	0.2	
	Temperature coefficient	–	30 ppm/°C from rated voltage following 30-minute warm-up.			
	Temperature drift	–	0.01 %+2 mV Change in output, over 8-hour interval under constant line, load and ambient temperature following 30-minute warm-up			
	UP Programming response time (*4)	ms	50	60	50	
	Down programming	Full load	ms	50	50	50
	Response time	No load	ms	500	500	750
	Load regulation (*5)	–	0.01 %+5 mA	0.07 %+10 mA	0.01 %+5 mA	
	Line regulation (*6)	–	0.01 %+2 mA	0.01 %+5 mA	0.01 %+2 mA	
Programming (*9)	RMS ripple (5 Hz–1 MHz Bandwidth)	mA	15	30	5	
	Temperature coefficient	–	100 ppm/°C from rated current following 30-minute warm-up.			
	Temperature drift (*8)	–	0.02 %+5 mA	0.05 %+10 mA	0.02 %+5 mA	
Overvoltage Protection (*10)	Resolution	–	Better than 0.028 % of rated output voltage			
	Voltage Accuracy	–	0.02 %+5 mV	0.02 %+5 mV	0.02 %+5 mV	
	Current Accuracy	–	Better than 0.03 % of rated output current			
	Resolution	–	0.4 %+40 mA			
Hold-up time		V	0-40	0-40	0-66	
		–	20 ms At 100 V/200 V AC, rated output voltage and output current.			

*1, *2, *3, *4, *5, *6, *8, *9, *10: annotation on page 52.

Specifications ZUP Series

Model		ZUP36-12	ZUP36-24	ZUP60-3.5	
Display	Voltage	3 digits (6 V; 20 V; 36 V; 60 V; 80 V); 3.5 digits (10 V; 120 V) accuracy: 0.2 % ±2 digits			
	Current	3.5 digits (132 A); All others 3 digits, accuracy: 0.5 % ±3 digits			
	Status	CV/CC, Alarm, Fold, Local/Remote, On/Off			
Output protections		Over Voltage, Over Temperature, Foldback.			
Input	Input voltage (*11)	85 – 265 V AC Continuous, 47–63 Hz			
	Input current (*12)	A	5.6/2.7	11.2/5.4	2.9/1.4
	Inrush current (100/200 V)	A	15	30	15/30 (*7)
	Efficiency (*12)	%	80/84	80/84	75/79
	Input current harmonics	Complies with EN61000-3-2, Class A			
	Power factor (TYP)	0.99 at 100/200 V AC, 100 % load.			
Environment	Operating temperature	0 to 50 °C ; 100 % Load			
	Operating humidity	30-90 % RH (No dewdrop).			
	Storage temperature	–20 to 70 °C			
	Operating humidity	10 – 95 % RH (No dewdrop).			
Mechanical	Vibration	10–55 Hz, Amplitude (sweep 1 min) 2 g, X, Y, Z, When mounted with mounting screws.			
	Shock	Less than 20 g			
	Weight	kg	3.2	5.8	2.9
	Size (WxHxD)	mm	200 W and 400 W units: 70 x 124 x 350. 800 W units: 140 X 124 X 350 (Refer to outline drawing)		
External control Functions	Output on/off	By TTL Signal or Dry Contact (Refer to instruction manual)			
	Output good	Open collector (Refer to instruction manual).			
	Output voltage programming	By Voltage (0–4 V) or by Resistance (0–4 K) (Refer to instruction manual).			
	Output current programming	By Voltage (0–4 V) or by Resistance (0–4 K) (Refer to instruction manual).			
	Remote sensing	Maximum 0.5 V drop on each load wire for model up to 60 V and 2 V for the 80 V, 120 V models			
	Communication interface	RS232 and RS485 Built-in, IEEE488 Optional.			
Approvals	Safety standards	UL3111-1, EN61010-1			
	EMC standards	EN61326-1, IEC 61326-1, FCC part 15 (class A)			
Conducted EMI		EN55022-B, FCC-B, VCCI-2			
Radiated EMI		EN55022-A, FCC-A, VCCI-1			
Series operation		Up to 2 units (Refer to instruction manual).			
Parallel operation		Master/Slave method; up to 5 units (Refer to instruction manual)			
Cooling		Forced air by blower fan (Blower fan is mounted within unit)			
Withstand options		Input – Chassis...2.0 kV AC 1 min, Input – Output...3.0 kV AC 1 min, Output – GND...500 V AC 1 min.			
Isolation resistance		More than 100 M at 25 °C and 70 % R.H.			

*1: Minimum voltage is guaranteed to maximum 0.2 % of the rated output voltage.

*2: Minimum current is guaranteed to maximum 0.4 % of the rated output current.

*3: Time for recovery to within ±50 mV against current change of 50 % to 100 %.

*4: From zero volts to full scale, resistive load and current setting at maximum.

*5: From no load to full load, constant input voltage.

*6: From 85~132 V AC or 170~265 V AC constant load.

*7: At cold start Ta=25 °C.

*8: Change in output over 8 hour interval constant line, load and ambient temperature following 30-minutes warm-up.

*9: Given for control of the output via the serial communication or via front panel controls.

*10: Inverter shut-down method, manual reset (OVP will shut-down output).

*11: For cases where conformance to various safety specs. (UL, IEC, etc.) are required, to be described as 100–240 V AC (50/60 Hz) on name plate.

*12: At 100 V/200 V and Maximum Output Power.



Single



Parallel (Master/Slave)

Parallel Operation

Master – Slave method: Active current sharing up to 5 units.

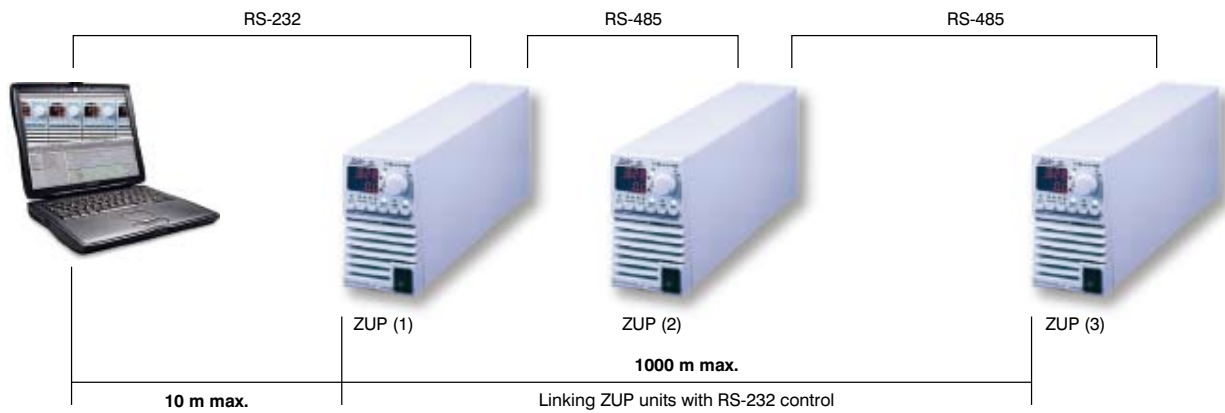

Remote Programming via RS-232

Up to 31 ZUP units can be controlled via RS-232 interface.

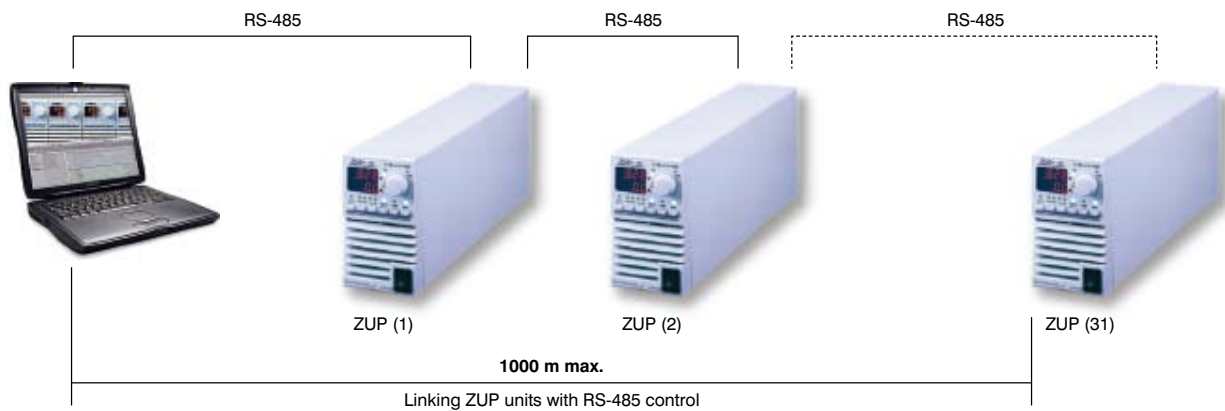

Remote Programming via RS-485

Up to 31 ZUP units can be controlled via RS-485 interface.

For operation environments that require high noise immunity or long distance communication, it is recommended to use the built-in RS-485 interface.

Remote programming via GPIB

GPIB – RS-485 Controller

The GP485A is a high performance serial to GPIB Interface. It enables a ZUP series with RS-485 port to be a Talker, Listener, or controller on the GPIB.

- Controls up to 31 ZUP units through a single GPIB address
- Conforms to all versions of the IEEE488 standard, including IEEE488.2
- 19" available
- Application software LabView, LabWindows

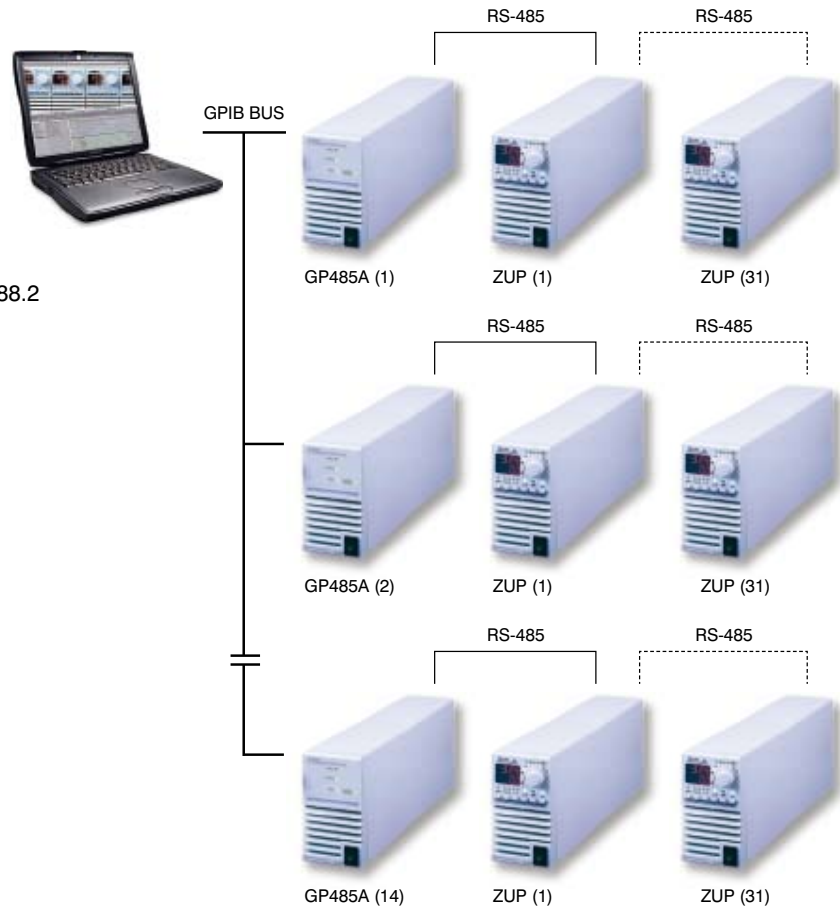

Rack mounted ATE and OEM

up to 2.4 kW

Six units can be assembled into 19-inch rack/3 U high to meet your configuration requirements.

Power Modules Table

Module Type	200 W	400 W	800 W
0 ~ 6 V	33 A	66 A	132 A
0 ~ 10 V	20 A	40 A	80 A
0 ~ 20 V	10 A	20 A	40 A
0 ~ 36 V	6 A	12 A	24 A
0 ~ 60 V	3.5 A	7 A	14 A
0 ~ 80 V	2.5 A	5 A	
0 ~ 120 V	1.8 A	3.6 A	
19" rack width	1/6 width	1/6 width	2/6 width



GP485A

The GP485A has all the software and logic required to implement the physical and electrical Specifications of the IEEE488 and RS-485 standards.

Front Panel



Front Panel

1. Power/Ready: Indicates that the power is ON and the self-test has passed successfully. The unit is ready to operate once the LED illuminates.
2. Talk: Indicates that the GP485A is addressed as a GPIB Talker.
3. Listen: Indicates that the GP485A is addressed as a GPIBListener.
4. SRQ: Indicates that the GP485A signal line SRQ is asserted.
5. AC ON/OFF: Turns AC power On and Off.

Rear Panel

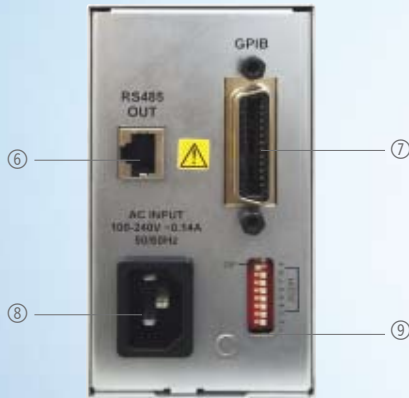

Rear Panel

6. RS-485 OUT: EIA-568A shielded type connector, used for RS-485 communication with ZUP power supplies.
7. GPIB: Shielded 24-pin Champ female connector, with metric screwlock. Used for GPIB communication with the GPIB controller.
8. AC Input: IEC type appliance inlet.
9. Address Select: 9 Position DP switch. Position 4 to 8 used for address selection.

Specifications

Input Voltag/freq	85 ~ 265 V AC continuous 47 ~ 63 Hz
Input consuption	5 W
IEEE 488 Capability	SH1, AH1, T6, TE0, L4, LE0, SR1, RL0, PP1, DC1, DT0, C0, E1, E2
Indication LED's	Power/Ready, Talk, Listen, SRQ
Baud rate	Optional 300, 600, 1200, 2400, 4800, 9600 Default:9600
Address	1 up to 30 can be set using an address switch
Operating temperature	0 ~ 50 °C
Storage temperature	-20 ~ 70 °C
Conducted emission	EN5022B, FCC-B
Radiated emission	EN5022A, FCC-A
Safety standards	UL3111-1, EN61010-1
EMC standards	EN61326-1, IEC 61326-1, FCC part 15 (class A).
Withstand voltage	Input – Chassis 2.0 kV AC 1 min, Input – Output 3.0 kV AC 1 min, Output – Chassis 500 V AC 1 min.
Vibration	10 – 55 Hz, Amplitude (sweep 1 min) 2 g, X, Y, Z, When mounted with mounting screws.
Size (WxHxD)	70 x 124 x 350 mm (GP 485 has all the mechanical specifications & mounting hole as ZUP 200 W/400 W units)
Weight	1.95 kg

Outline drawings ZUP

200 W / 400 W Units

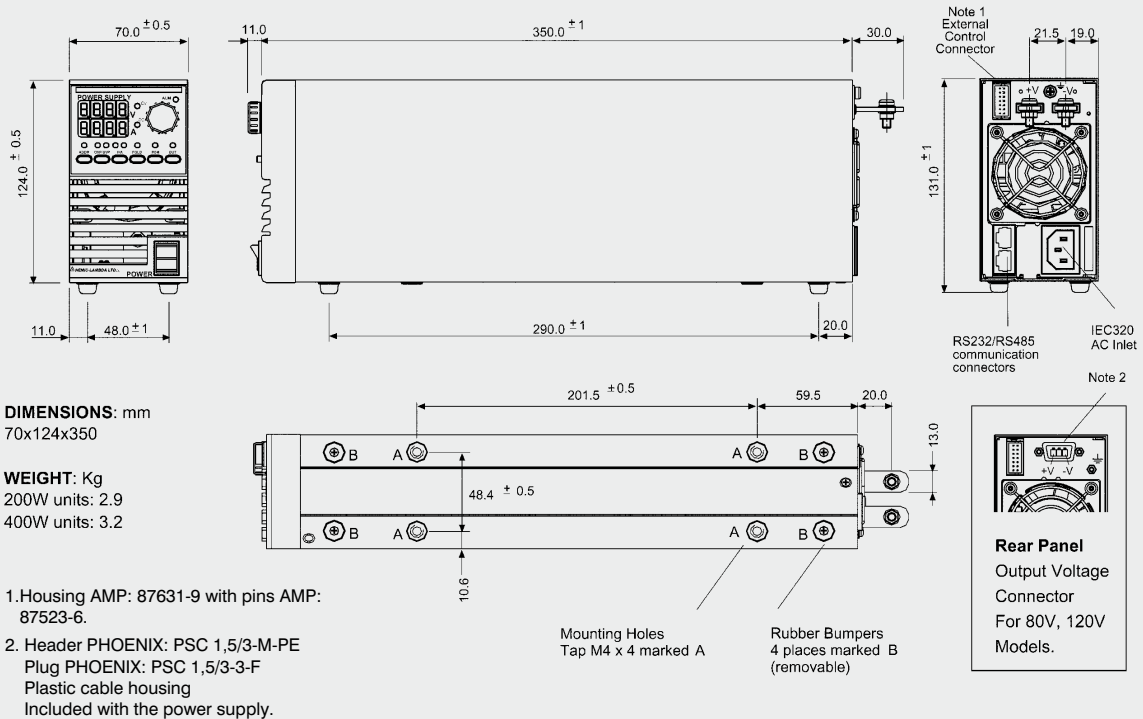

Outline drawings ZUP

800 W Unit

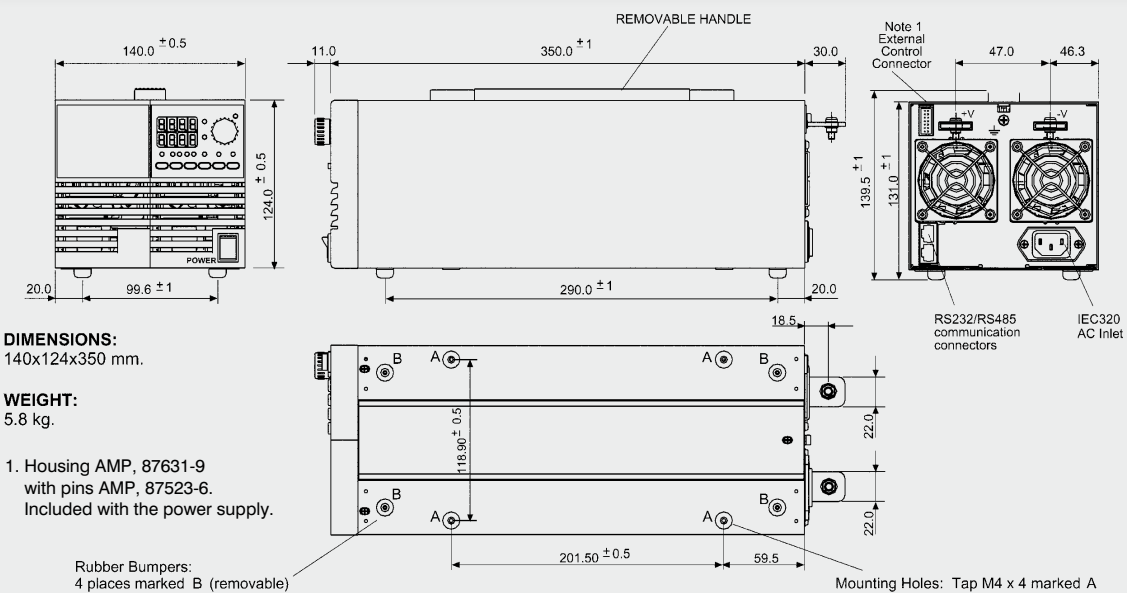



Options

200 W / 400 W / 800 W models

1. Front Panel Output Jacks

Up to 20 A output current via front panel jacks, only for models up to 60 V output voltage.

Outline Drawing: Physical Dimensions in mm.

ZUP 200 W/400 W Units: 70 x 153 x 405.9

ZUP 800 W Units: 140 x 153 x 405.9

P/N: ZUP / L

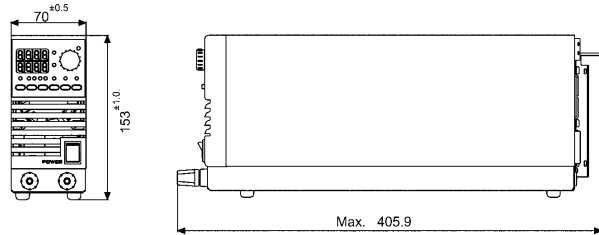

2. ZUP Assemblies

Dual Output Packing 200 W/400 W models

P/N: NL200

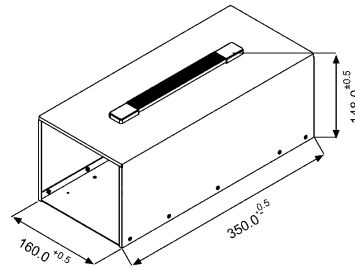

3. 19" Rack mounted and OEM up to 2.4 kW

Up to six power units can be assembled into a 19, 3 U rack, kit.

P/N NL100



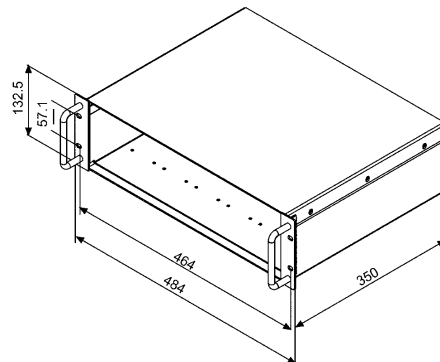

In cases where the entire rack is not occupied with power units, NL101 blank panels can be installed. P/N: NL100



Accessories

1. AC Cord Sets

Three optional cords are possible according to order:

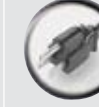
Region	Europe	United Kingdom	Japan	Middle East	North America
Output Power AC Cords	750 W 10 A / 250 V AC L=2 m	750 W 10 A / 250 V AC L=2 m	750 W 13 A / 125 V AC L=2 m	750 W 10 A / 250 V AC L=2 m	750 W 13 A / 125 V AC L=2 m
Wall Plug Power Supply Connector	INT'L 7/III IEC320-C13 	BS1363 IEC320-C13 	IEC320-C13 	SI-32 IEC320-C13 	NEMA 5-15P IEC320-C13 
Part Number	P/N: ZUP/E	P/N: ZUP/GB	P/N: ZUP/J	P/N: ZUP/I	P/N: ZUP/U

2. Communication Cable

RS-232/RS-485 cable is used to connect the power supply to the PC controller

Mode	PC connector	Communication cable	Power Supply Connector	P/N
RS232	DB-9	Shield Ground L=1 m	EIA / TIA-568A (RJ-45)	ZUP/NC401
RS232	DB-25	Shield Ground L=1 m	EIA / TIA-568A (RJ-45)	ZUP/NC403
RS485	DB-9	Shield Ground L=1 m	EIA / TIA-568A (RJ-45)	ZUP/NC402
RS485	DB-25	Shield Ground L=1 m	EIA / TIA-568A (RJ-45)	ZUP/NC404

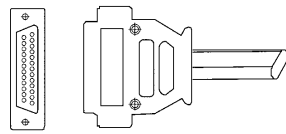

DB-25 (female connector)

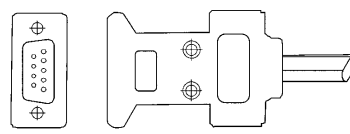

DB-9 (female connector)



EIA/TIA (RJ-45)

3. ZUP serial link cable

Used to chain Power Supply to Power Supply from a serial communication bus

Mode	Communication cable	Power Supply Connector Remote IN /OUT	P/N
RS485	Shield Ground L=50 cm	EIA / TIA-568 A (RJ-45)	ZUP/W







Innovating Reliable Power

TDK-Lambda

With production facilities in Asia, America and Europe, TDK-Lambda has positioned itself as one of the world's largest manufacturers of electronic power supplies. Boasting a comprehensive range of AC/DC power supplies, DC/DC converters and laboratory power devices ranging from 1.5 W to 15 kW, TDK-Lambda offers the right solution for a host of different applications.

“Power supply” to us is more than just an electronic device. It is the fundamental basis of the safety and reliability of our customers' products. This is why we support you with everything from design, EMC standards and safety certification to serial production, so that we are confident of offering you the best possible solution in every aspect.

More detailed information:

Visit our website and discover the many possibilities offered by TDK-Lambda. Browse through the latest product highlights and download our catalogues and documentations.

www.emea.tdk-lambda.com



Please contact your local sales office to find the best solution to your application.



TDK-Lambda Germany GmbH
Karl-Bold-Strasse 40
77855 Achern
Tel. +49 7841 666 0
Fax +49 7841 5000
info.germany@de.tdk-lambda.com
www.emea.tdk-lambda.com



TDK-Lambda Italy S.r.l.
Via dei Lavoratori 128/130
20092 Cinisello Balsamo (MI)
Italy
Tel. +39 02 61 29 38 63
Fax +39 02 61 29 09 00
info.italia@it.tdk-lambda.com
www.it.tdk-lambda.com



TDK-Lambda Austria Sales Office
Aredstrasse 22
2544 Leobersdorf
Tel. +43 2256 655 84
Fax +43 2256 645 12
info.germany@de.tdk-lambda.com
www.emea.tdk-lambda.com



TDK-Lambda Corporation
5F Dempa Bldg. 1-11-15
Higashigotanda
Shinagawa-Ku
Tokyo, 141-0022
Japan
Tel. +81 3 3447 4693
Fax +81 3 3447 4750
www.jp.tdk-lambda.com



TDK-Lambda Scandinavia Sales Office
PO Box 546
Rallarvägen 41
184 40 Åkersberga
Sweden
Tel. +46 854 084 990
Fax +46 854 066 096
info.germany@de.tdk-lambda.com
www.emea.tdk-lambda.com



Nemic Lambda Ltd.
Kibbutz Givat
Hashlosha 48800
Israel
Tel. +9 723 902 4333
Fax +9 723 902 4777
www.nemic.co.il



TDK-Lambda UK Ltd.
Kingsley Avenue
Ilfracombe
Devon EX34 8ES
United Kingdom
Tel. +44 12 71 85 66 66
Fax +44 12 71 86 48 94
powersolutions@emea.tdk-lambda.com
www.uk.tdk-lambda.com



TDK-Lambda Americas Inc.
3055 Del Sol Blvd.
San Diego, CA 92154
USA
Tel. +1 800-LAMBDA-4
Tel. +1 619-575-4400
Fax +1 619-429-1011



TDK-Lambda France SAS
ZAC des Delaches
BP 1077-Gometz-le-Chatel
91940 LES ULIS
France
Tel. +33 1 60 12 71 65
Fax +33 1 60 12 71 66
france@fr.tdk-lambda.com
www.fr.tdk-lambda.com



TDK-Lambda EMEA
www.emea.tdk-lambda.com