

REV.	DESCRIPTION	DATE
A	NEW DRAWING	8/28/2008

1

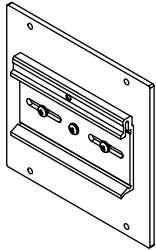

VHK-DRA  
QTY: 1

2



M4X0.5  
5mm length  
QTY: 4

3

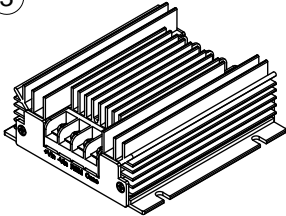

V-INFINITY CHASSIS  
MOUNT DC-DC  
CONVERTER  
QTY: 1  
(sold separately)

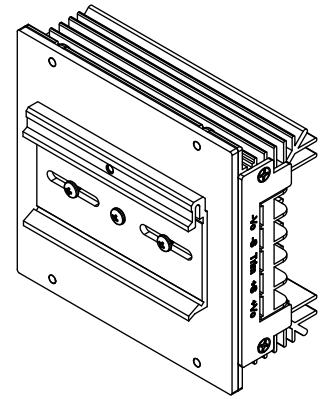
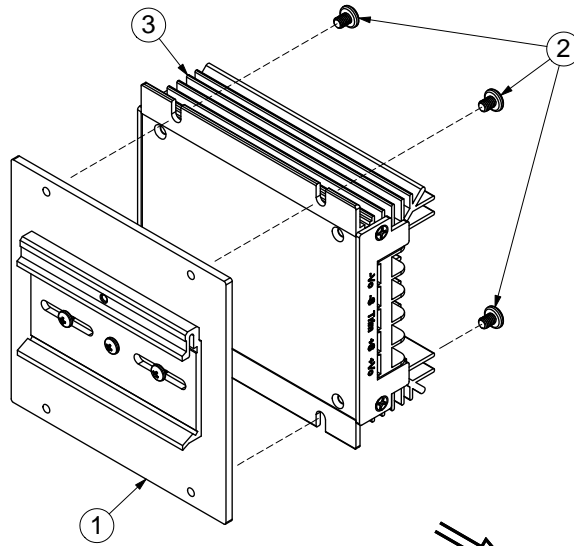

PC FILE NAME:  
VHK-DIN

COPYRIGHT 2008 BY CUI INC.

TITLE: DIN RAIL MOUNTING BRACKET ASSEMBLY INSTRUCTIONS		REV: A
PART NO: VHK-DIN	UNITS: MM [INCHES]	
DRAWN BY: ZRJ	APPROVED BY:	SCALE: 1:2

REV.	DESCRIPTION	DATE
A	NEW DRAWING	8/22/2008

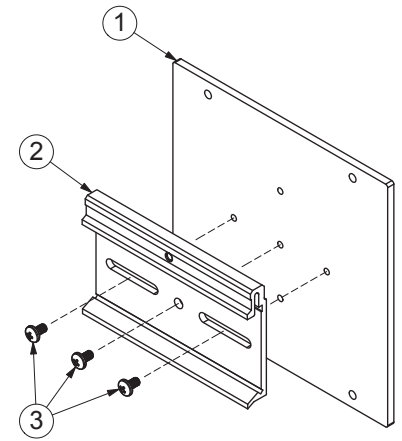
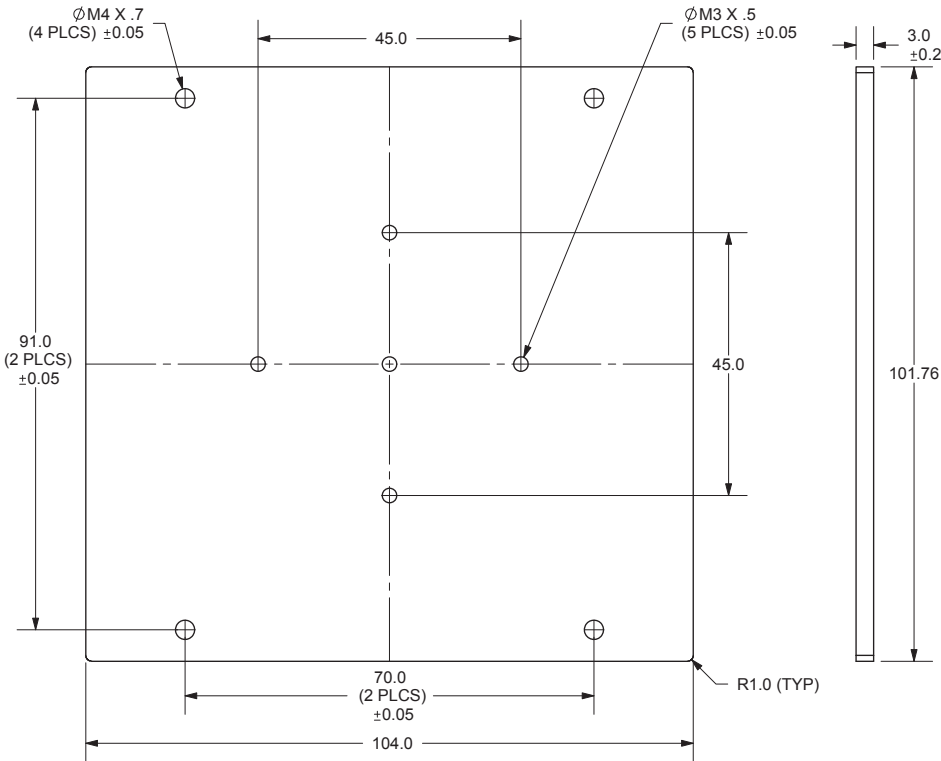

ASSEMBLY DRAWING



20050 SW 112th Ave.  
Tualatin, OR 97062  
Phone: 503-612-2300  
800-275-4899  
Fax: 503-612-2383  
Website: www.cui.com

ITEM	DESCRIPTION	QUANTITY
1	MOUNTING PLATE	1
2	VDRP-02	1
3	M3X5 SCREWS	3

TITLE: DIN RAIL MOUNTING BRACKET ASSEMBLY INSTRUCTIONS		REV: A
PART NO: VHK-DRA	UNITS: MM [INCHES]	
DRAWN BY: ZRJ	APPROVED BY:	SCALE: 1:1

PC FILE NAME:

COPYRIGHT 2008 BY CUI INC.

REV.	DESCRIPTION	DATE
A	NEW DRAWING	8/30/2008

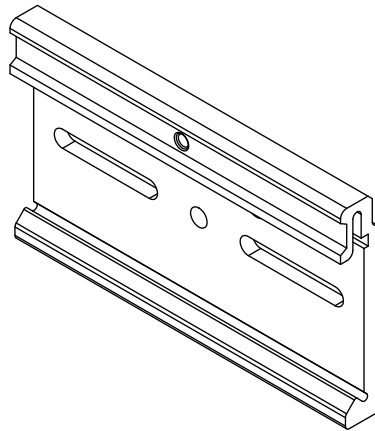
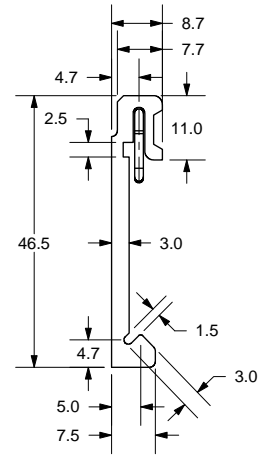
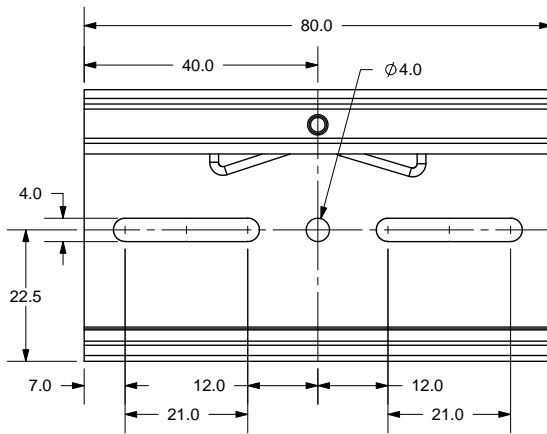

TOLERANCE:  
±0.3mm UNLESS OTHERWISE  
SPECIFIED

MATERIAL: ALUMINUM



20050 SW 112th Ave.  
Tualatin, OR 97062  
Phone: 503-612-2300  
800-275-4899  
Fax: 503-612-2383  
Website: www.cui.com

TITLE: DIN RAIL MOUNTING BRACKET ASSEMBLY INSTRUCTIONS		REV: A
PART NO: VDRP-02	UNITS: MM [INCHES]	
DRAWN BY: ZRJ	APPROVED BY:	SCALE: 1:1

PC FILE NAME:

COPYRIGHT 2008 BY CUI INC.