

REV.	DESCRIPTION	DATE
A	NEW DRAWING	9/15/2008

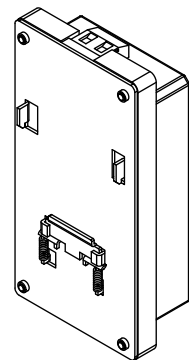
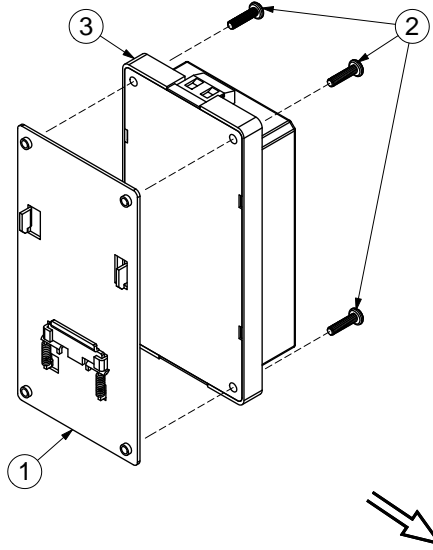
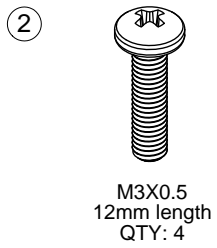
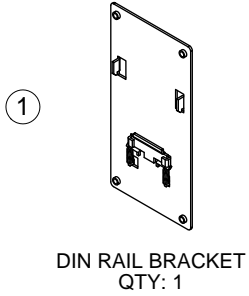

PC FILE NAME:  
FSC-S30-DIN

COPYRIGHT 2008 BY CUI INC.

TITLE: DIN RAIL MOUNTING BRACKET ASSEMBLY INSTRUCTIONS		REV: A
PART NO: FSC-S30-DIN	UNITS: MM [INCHES]	
DRAWN BY: ZRJ	APPROVED BY:	SCALE: 1:2

REV.	DESCRIPTION	DATE
A	NEW DRAWING	9/15/2008

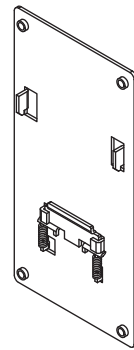
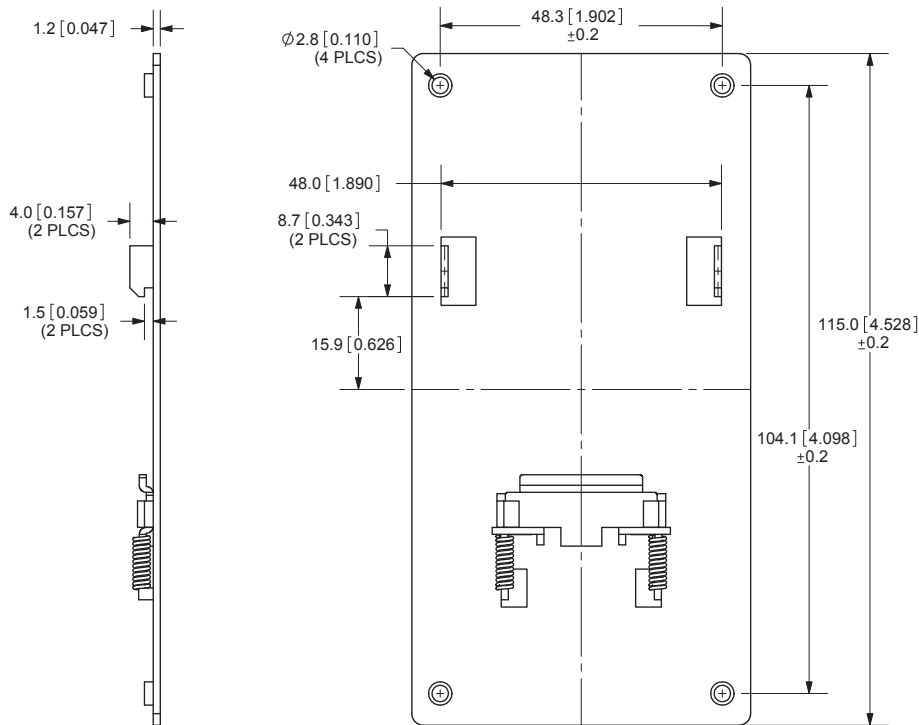

SCALE: 1:2

TOLERANCE:  
±0.3mm UNLESS OTHERWISE  
SPECIFIED



20050 SW 112th Ave.  
Tualatin, OR 97062  
Phone: 503-612-2300  
800-275-4899  
Fax: 503-612-2383  
Website: www.cui.com

TITLE: DIN RAIL MOUNTING BRACKET ASSEMBLY INSTRUCTIONS		REV: A
PART NO. DIN RAIL BRACKET	UNITS: MM [INCHES]	
DRAWN BY: ZRJ	APPROVED BY:	SCALE: 1:1

PC FILE NAME:

COPYRIGHT 2008 BY CUI INC.