

Invensys

LAMBDA 

INSTRUCTION MANUAL

LZS/SE-1000 SERIES POWER SUPPLY

3055 Del Sol Blvd
San Diego, Ca. 92154
Phone (619) 575-4400
Fax (619) 575-7185

P/N: IMLZSSE1000 Rev. B
DATE: July 2002

LZS SERIES INSTRUCTION MANUAL

ALL INFORMATION CONTAINED IN THIS MANUAL APPLIES TO BOTH THE LZS-1000 AND SE-1000 POWER SUPPLY SERIES EXCEPT AS SPECIFIED BELOW

Addendum to IM-LZS/SE1000 Instruction Manual

SE-1000 POWER SUPPLY SERIES

This document is a brief description of specifications, features and applications that are particular to SE-1000 power supplies. For more detailed information, please consult SE Applications Manuals, available from your local Sales Representative or the Lambda Factory.

Input Voltage Range:	105 -140 vac (47-63hz)
Input Voltage (peak):	170 vac for 1 second (non-repetitive)
Input Current (rms max.):	20.0 amps, at 105 vac input
Input E.M.I. Emissions:	Conducted FCC Part 15 Subpart J (Class B) MIL-STD-461 D, CE102
Efficiency (at max. output power):	74% typical, at 105 vac input 75% typical, at 115 vac input

GUIDE TO APPLICATION

INPUT VOLTAGE

The input circuit of the SE series is permanently configured as a voltage doubler, providing reliable AC input operation for the range of 105-140 vac (47-63hz). Consult factory for operation at frequencies other than 47-63hz. Regulatory agency compliance applies only for operating frequencies between 47-63hz. (Regulatory agency compliance testing is in process at the time of this printing. Check units' chassis for appropriate agency logo(s) to determine whether a particular unit is agency approved.)

This manual is a brief description of specifications, features and applications of LZS-1000 power supplies. For more *detailed* information, please consult the LZS Applications Manual, available from your local Sales Representative or the Lambda Factory.

LZS SERIES INSTRUCTION MANUAL

RATINGS AND SPECIFICATIONS:*

I. Maximum Ratings:

	Units	LZS-1000-1	LZS1000-2	LZS1000-3
Output Voltage Range	V	4.75 – 6.30	11.4 – 15.75	19.0 – 29.4
Output Current(Power) @ 40°C**	A(W)	200 (1050)	83 (1050)	50 (1050)
Output Current(Power) @ 50°C**	A(W)	190 (998)	80 (998)	48 (998)
Output Current(Power) @ 60°C**	A(W)	160 (840)	67 (840)	40 (840)
Output Current(Power) @ 71°C**	A(W)	120 (630)	50 (630)	30 (630)
Operating Temperature	°C	Continuous duty from –30 to +71		

II. Input Specifications:

	Units	
Input Voltage Range		Autoselectable: 85 – 132 or 170 - 265 VAC (47 - 440 Hz), or 220 - 380 VDC.***
Input Current (RMS, maximum)	A	22, at 85 VAC input.
Inrush Current (Peak, at cold start.)	A	40, at 115 VAC input 80, at 230 VAC input
Input Power (maximum)	W	1428, at 85 VAC input
Input Surge Protection		Meets IEEE 587-1980 Class A for branch circuits and outlets.
Input EMI Conducted Emissions		FCC Part 15 Subpart J (Class B) VDE 0871 (Class B) MIL-STD-461C, CE-03
Efficiency (at maximum output power)	%	73.5% minimum, at 85 VAC input
	%	75% typical, at 115 VAC input

III. Output Performance Specifications:

	Units	LZS-1000-1	LZS-1000-2	LZS-1000-3
Voltage Line Regulation	%	0.1% of Vo		
Voltage Load Regulation	%	0.1% of Vo		
Ripple and Noise @ 20 MHz measurement Bandwidth.	mV	10 (RMS)	10(RMS)	10(RMS)
		35 (pk. To pk.)	50 (pk. To pk.)	100 (pk. To pk.)
Temperature Coefficient	%/°C	0.025		
Startup Time (at 110 VAC input)	ms	1500 max.		
Overshoot	mv	No overshoots at turn on, turn off, power failure or removal of short circuit.		
Holdup Time (at 115 VAC, 5.25 VDC output and 200 A load)	ms	26	N/A	N/A
Load Transient Response 50% to 100% load change)		Recovery to within regulation limits within 50 ms. Maximum output voltage excursion less than 7.5% for -1 model and less than 5% for -2 and -3 models.		

* Refer to figures 1-7 for supply-load connection information.

** Output current and power, as measured at output terminals, must be less than or equal to quoted maximum values for a given ambient temperature.

*** For DC input, the source voltage must reach 220 VDC within 750 ms. Or the autoselect circuit may activate the voltage doubler and cause the input capacitor overvoltage protection circuit to blow the line fuse.

LZS SERIES INSTRUCTION MANUAL

RATINGS AND SPECIFICATIONS:* (CONT'D)

IV. Operating Modes:

Series Operation	Yes (see Fig. 7)
Parallel Operation (with current sharing)	Two or more identical units (see Fig. 6). (Use of TB201 Terminal 5 will provide current sharing to within 3% nominal of rated 40°C current.)

(Refer to figures 1-7 for supply-load connection information.)

FEATURES:

I. DC Output Controls and Indicators:

Output Voltage Adjust	Screwdriver adjustment over entire range. (Multi-turn potentiometer accessible from terminal end of chassis.)
Overvoltage Protection Adjust	Screwdriver adjustment over entire range. (Multi-turn potentiometer accessible from terminal end of chassis.)
Output Good Indicator	Green colored LED illuminates when output is within specified operating range.
Fault Indicator	Red colored LED illuminates if overvoltage or overtemperature shutdown occurs. (Loss of illumination after removal of AC power indicates that OV/OT shutdown circuit has fully reset.)

II. Remote Control Features:

Remote Voltage Sensing	Provides precise regulation directly at load (see Fig. 3). (Maximum total DC voltage drop between output terminals and load must be limited to <1.0 V. In addition, the voltage at the output terminals must be limited to 6.3 V for -1, 15.75 V for -2, and 29.4 V for -3 models.)
Remote Voltage Programming via external resistor,	1000 ohms per volt for resistor connected between pins 1 and 2 on TB201 (see Figs. 4 and 5).
Remote Voltage Programming via external voltage source,	Volt per volt for voltage source connected between pins 1 and 2 on TB201 (see Figs. 4 and 5).
Remote On/Off Control.	Enable/Disable output via TTL voltage level compatible signal connected between pins 6 and 7 of TB201 (or "D" connector).
Signal Isolation:	Pins 6 and 7 are fully isolated from all other power supply terminals.
Signal Logic:	Logic zero (below 0.7 V), short circuit or open circuit disables power supply output. Logic one (above 2.5 V) enables power supply output.
Signal Current draw:	Current draw from Logic 1 input is less than 4 mA.
Output Response Time:	Output will be within specified limits within 50 ms. of application of logic "1" signal on -1 models, 100 ms. on -2 and -3 models.
Signal Enable:	Remote on/off function must be enabled by moving "OUTPUT ENABLE" switch at terminal end of chassis from "LOCAL" to "REMOTE" position.

LZS SERIES INSTRUCTION MANUAL

FEATURES: (CONT'D)

III. Auxiliary Monitoring and Alarm Signals: Optically coupled, conductance outputs.
(Conduct up to 1 mA at a voltage of <0.4 V, when active.)

Input Power Good Signal	Conductance signal which indicates adequate input capacitor voltage to provide 6 ms holdup time when operating -1 model @ 5.25 V, 200 A; -2 model @ 12.6 V, 83 A; or -3 model @ 21 V, 50 A.
Output Good Alarm Signal	Conductance signal which indicates that delivered output voltage, as measured at the +V and -V terminals, is above its minimum specified value.
Inverter Good Signal	Conductance signal which indicates that the power supply's inverter is functional. At very light loads, this signal may be indeterminate.
Signal Isolation	Input power good, output good alarms, inverter good and remote on/off signals are isolated from power supply output and each other for voltages up to 500 volts, minimum. 3000 VAC isolation from AC input to all auxiliary signals.

IV. Protection Features:

	Units	LZS-1000-1	LZS-1000-2	LZS-1000-3
Overcurrent Protection	%	Current limiting to 110% of max. rated 40°C load.		
Overvoltage Protection (adjustable)	V	6.5- 7.5	13.3- 17.5	22.1 -31.3
Nominal Factory Set Point:	V	6.8 - 6.9	16.9 - 17.0	30.9 - 31.0
Thermal Protection		Non-self-resetting thermostat.*		
Fusing (Replace only with same type and rating.)		F601: 30A/600 VAC (Line Fuse) F201, F202:0.5A/250V, F203:3A/250V F204: 15A/600V,		
Isolation Voltages	VAC VDC VAC	3000, Input to Output 500, Output to Chassis Ground 1500, Input to Chassis Ground		
Regulatory Agency Compliance **		UL1950 (SELV output) CSA E. B. 1402C, C22.2 No. 234-M90 (SELV output) IEC 950 (SELV output)		
Leakage current (AC line to chassis ground)	mA	less than 3.5 (when operated at 250 VAC (47 - 63 Hz), or lower voltages).		

* See "OVERTEMPERATURE AND OVERVOLTAGE SHUTDOWN" on page 7.

** Evaluation in process. Check unit chassis for appropriate logos to determine approval status of a given unit.

LZS SERIES INSTRUCTION MANUAL

FEATURES: (CONT'D)

V. Mechanical Features:

	units	
Storage Temperature (non-operating)	°C	-40 to + 85
Weight	Lbs	15.0 Net 17.5 Shipping
Size	inches	4.75 x 5.63 x 10.5
Finish		Black, Fed. Std. No. 27038
Mounting		One mounting surface (mounting position not restricted) Maximum allowable penetration into power supply is 1/4". (Requires No M4 (metric) hardware - supplied with unit.)

VI. Input and Output Connections:

Input	Heavy duty, chassis mounted terminal block with safety cover. (Cable clamp provided to secure line cord.)
Chassis ground	6-32 tapped hole and screw provided in chassis.
DC output	Heavy-duty bus bars with 1/4" clearance holes for load connections. (Connection hardware supplied with unit.)
Local/Remote voltage sensing, Remote on/off, Parallel operation	Seven-position lugless connector (TB201). See Fig. 1. (Accepts up to #14 AWG size stripped wire.)
Auxiliary Control and Alarm Signals	Connections for remote and local sensing, remote on/off parallel operation current sharing, input power good signal, output good alarm, Inverter good signal and chassis are available via chassis mounted, 15-pin, female, sub-miniature "D" connector (see Fig. 1).

VII. Other Features:

Guarantee	5 years, parts and labor.
Cooling	Fan cooled, using high quality, ball bearing fan.
Fungus Inert	All LZS power supplies are inherently fungus inert.

LZS SERIES INSTRUCTION MANUAL

GUIDE TO APPLICATION

SAFETY NOTICE

Dangerous voltages exist in this equipment. Observe the usual safety precautions when operating, wiring, or servicing to reduce the risk of shock or injury.

INPUT VOLTAGE

Input circuit configuration is automatically selected by internal circuitry for all input voltage ranges. If an input voltage of greater than 165 VAC (or 215 VDC) is applied, the voltage doubler configuration of the input circuit is automatically locked out and will not be reconnected unless input power is interrupted. (Reset time is less than 30 seconds).

Although LZS-1000 power supplies will reliably operate from AC input voltages between 85 - 132 and 170 - 265 VAC, regulatory agency compliance is only applicable for line voltages between 90 - 127 and 180 - 250 VAC, and frequencies between 47 and 63 Hz. (Regulatory agency compliance testing is in process at time of this writing. Check unit's chassis for appropriate agency logo(s) to determine whether a particular unit is agency approved.)

OUTPUT VOLTAGE

This power supply operates as a constant-voltage source with maximum load ratings as listed on page 1. If the load current tries to exceed 110% of the 40°C rating, output voltage will begin to decrease toward zero, thereby limiting the current delivered to the load. Upon removal of overload, normal operation will resume.

When shipped from the factory, the power supply is ready for use with output voltage set nominally at 5.0, 12.0 and 24.0 volts, respectively, for the -1, -2 and -3 models. Jumpers are in place on TB201 for local voltage sensing. Where precise regulation is required directly at the load, remote voltage sensing can be utilized. This can be achieved by utilizing the remote sense terminals on TB201 or "D" connector (see Figs. 1 and 3).

As shown on page 1, LZS-1000 power supplies have both a maximum current rating and a maximum output-power rating (as a function of ambient temperature). Care should be taken to limit both output current and output power to be within specified limits. If these limitations are not adhered to, the internal thermal protection circuit may shut down the power supply's operation. For remote voltage sensing, the maximum limits for output power, as given on page 1, apply at the power supply output terminals, not at the remote sensing point.

OVERVOLTAGE PROTECTION CIRCUIT ADJUSTMENT

The overvoltage protection circuit provides an adjustable means of disabling the DC output if it should exceed a pre-determined safe value. When shipped from the factory, the overvoltage level on each LZS unit is set as given on page 3. If a different OV threshold is required, it can be adjusted using the following method:

1. Turn the OV Adjust potentiometer fully CW (at least 10 turns).
2. With the power supply unloaded, set V_o to the OV threshold desired. This may require remote programming (see Figs. 4 and 5).
3. Slowly turn the OV adjust control CCW while monitoring the output voltage. Stop turning the control immediately when the red FAULT indicator lights, indicating an OV shutdown. At this point, the OV threshold is set to the desired value.

LZS SERIES INSTRUCTION MANUAL

OVERTEMPERATURE AND OVERVOLTAGE SHUTDOWN

LZS-1000 power supplies will automatically shut down if operating conditions cause excessive internal heating or excessive output voltage. After the occurrence of an overtemperature (or an overvoltage) shut down, input power must be interrupted to re-establish the output. After the cause of the overtemperature or overvoltage shutdown has been removed, the shutdown circuit will reset in less than 30 seconds after the removal of input power.

AUXILIARY CONTROL AND ALARM SIGNALS

LZS power supplies provide auxiliary control and alarm signals per page 4. These signals are accessible via the 15-pin, sub-miniature "D" connector, available below the output terminals of the unit.

LZS SERIES INSTRUCTION MANUAL

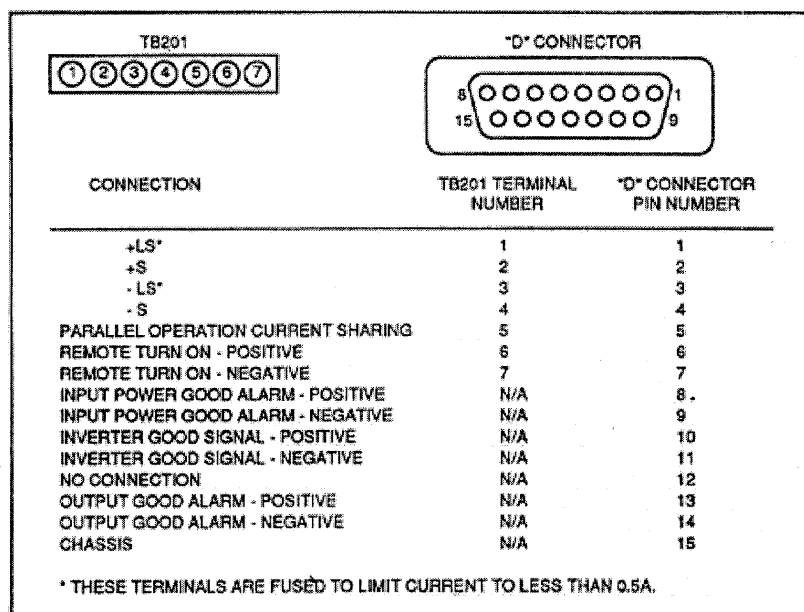

FIGURE 1: PINOUT FOR TB201 AND CHASSIS MOUNTED "D*" CONNECTOR

LZS SERIES INSTRUCTION MANUAL

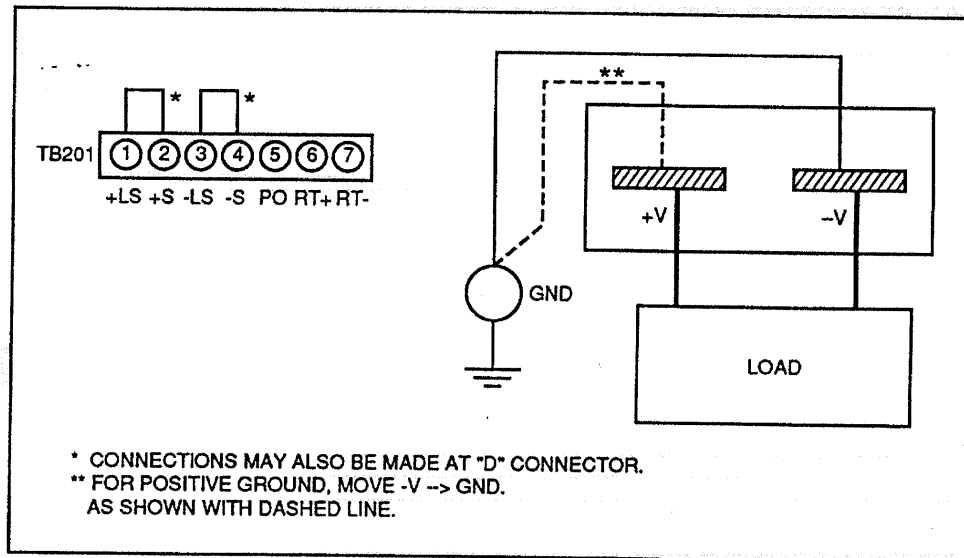

FIGURE 2: TYPICAL LOCAL SENSE CONNECTION

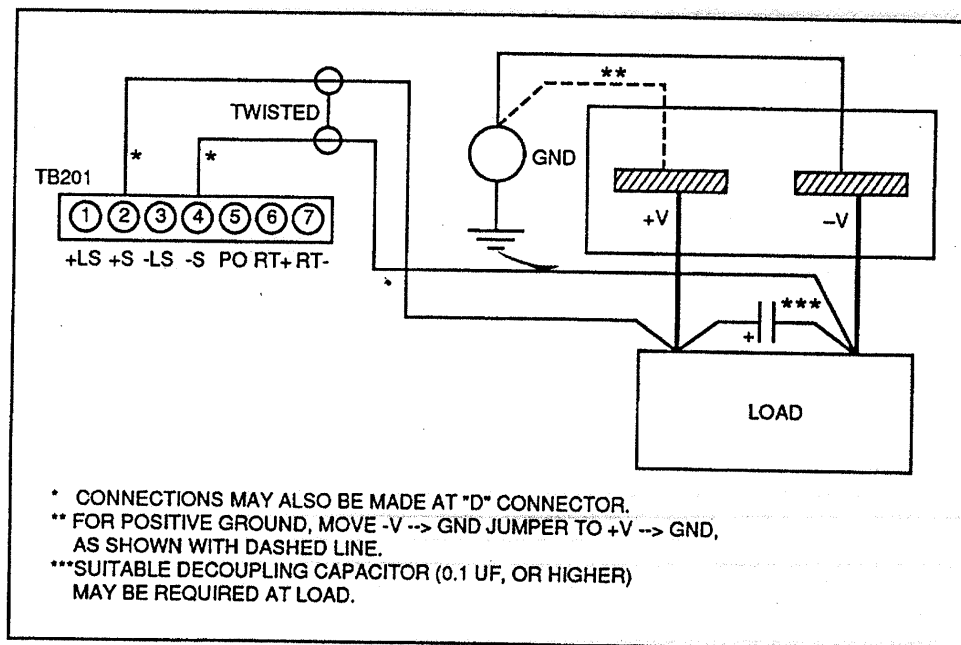

FIGURE 3: TYPICAL REMOTE SENSE CONNECTION

LZS SERIES INSTRUCTION MANUAL

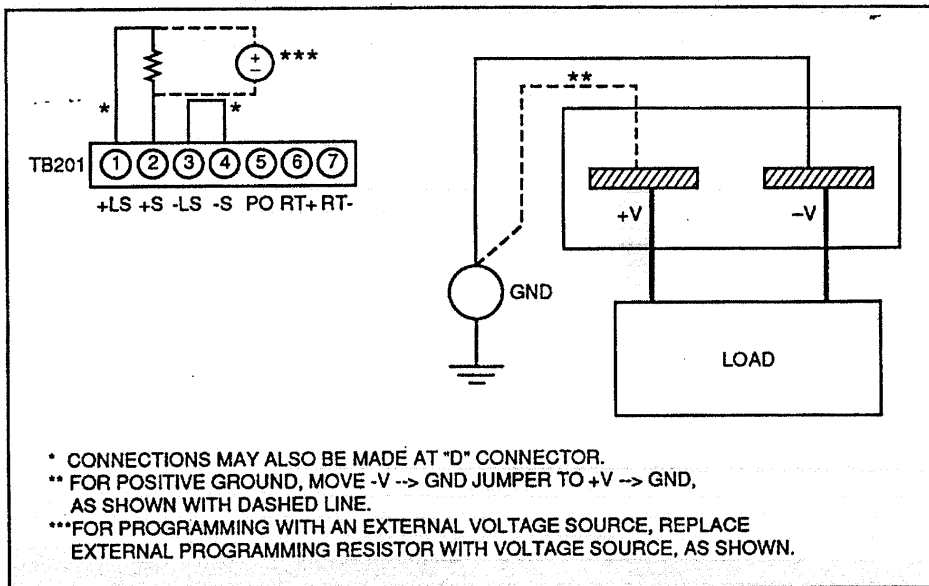

FIGURE 4: REMOTE VOLTAGE CONTROL WITH AN EXTERNAL PROGRAMMING RESISTOR OR VOLTAGE SOURCE (LOCAL SENSING)

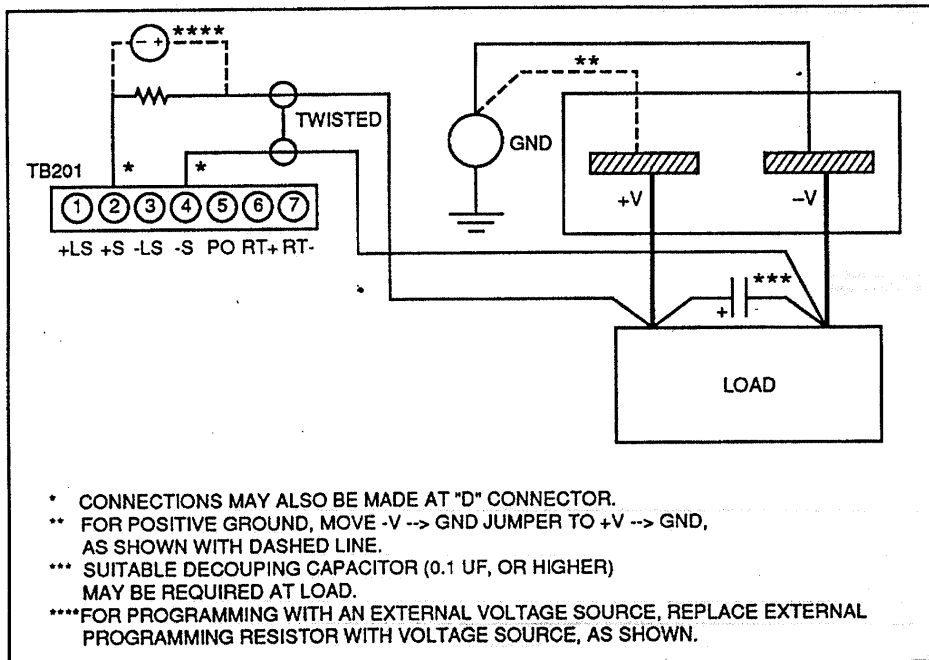
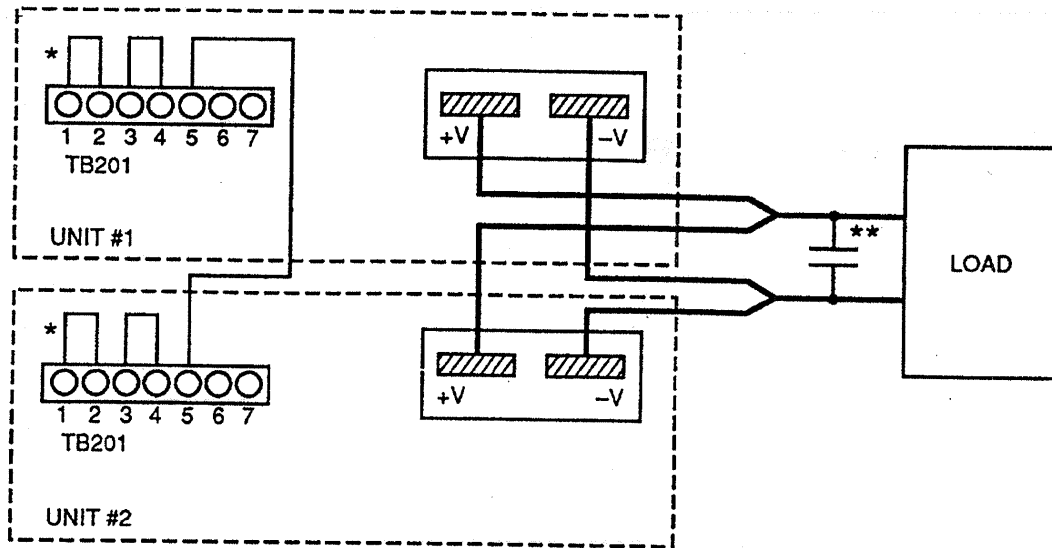
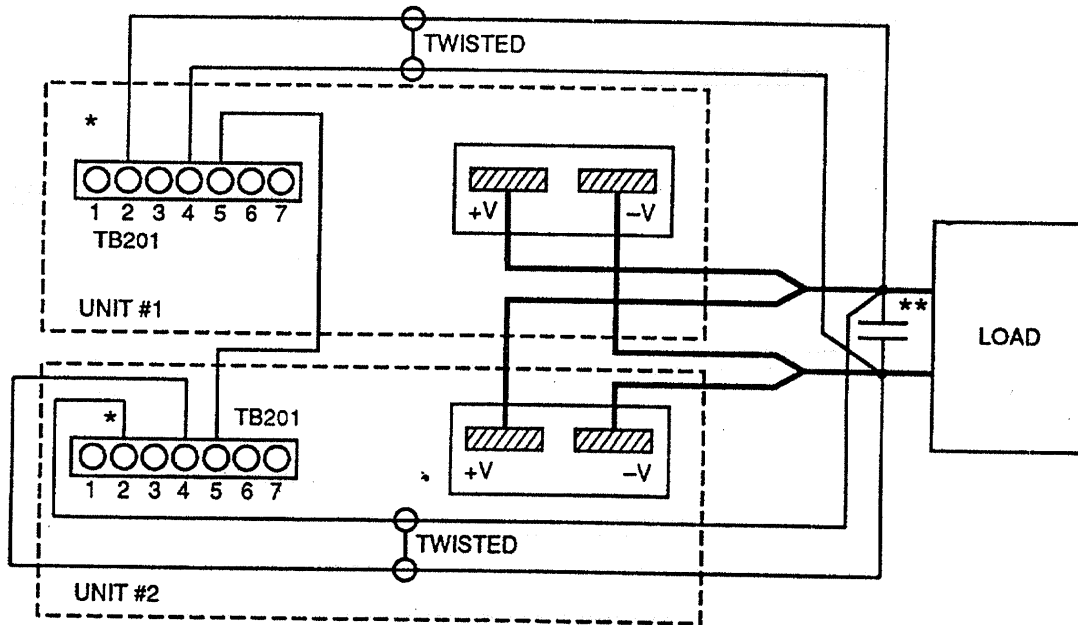

FIGURE 5: REMOTE VOLTAGE CONTROL WITH AN EXTERNAL PROGRAMMING RESISTOR OR VOLTAGE SOURCE (REMOTE SENSING)

LZS SERIES INSTRUCTION MANUAL



A) LOCAL SENSING



B) REMOTE SENSING

- * TB201 CONNECTIONS CAN ALSO BE MADE AT "D" CONNECTOR
- ** SUITABLE DECOUPLING CAPACITOR (0.1UF, OR LARGER) MAY BE REQUIRED AT LOAD.

FOR OPTIMAL PERFORMANCE, POWER SUPPLIES SHOULD HAVE THEIR OUTPUT VOLTAGES SET TO WITHIN 1% OF EACH OTHER.

FIGURE 6: PARALLEL OPERATION

LZS SERIES INSTRUCTION MANUAL

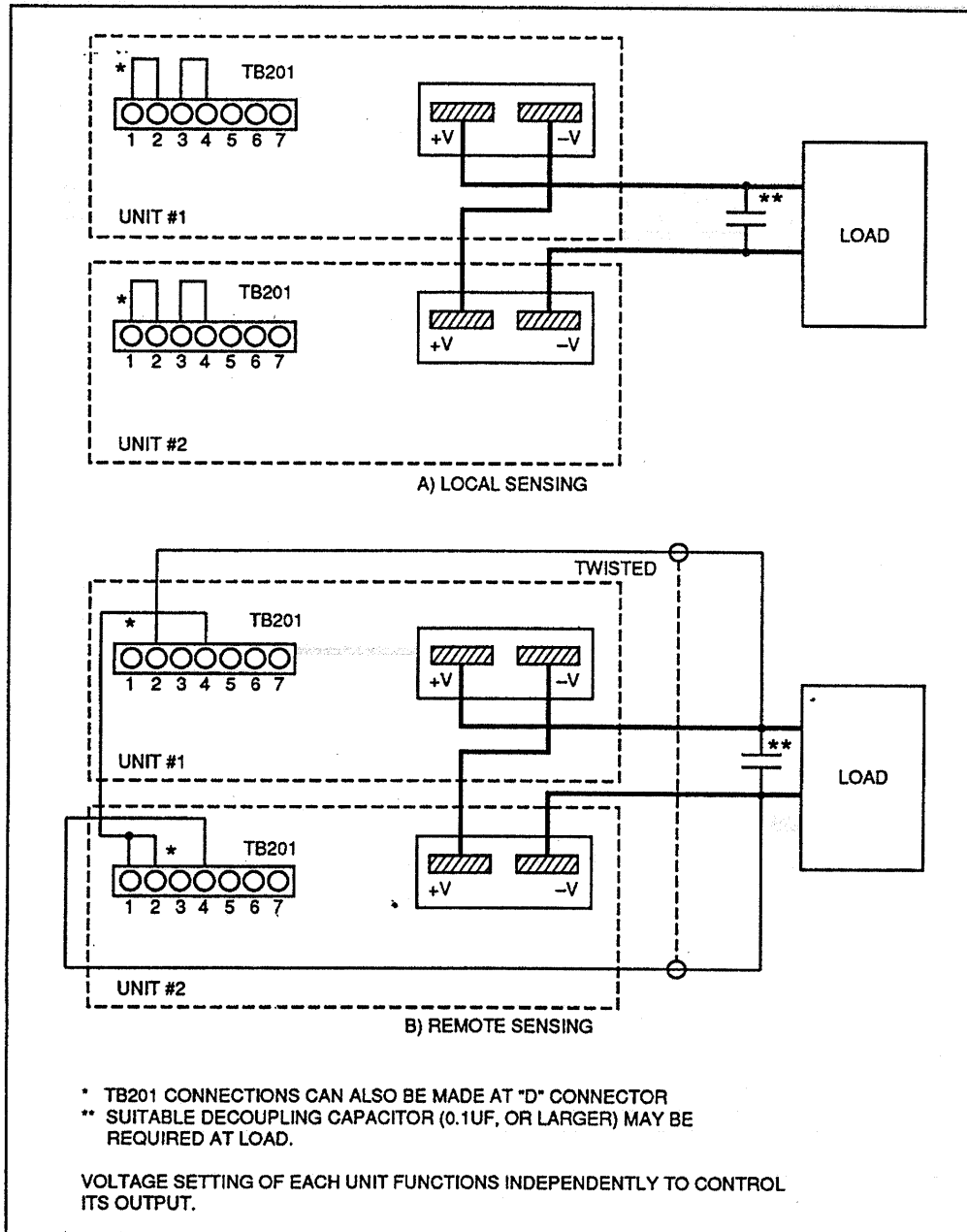
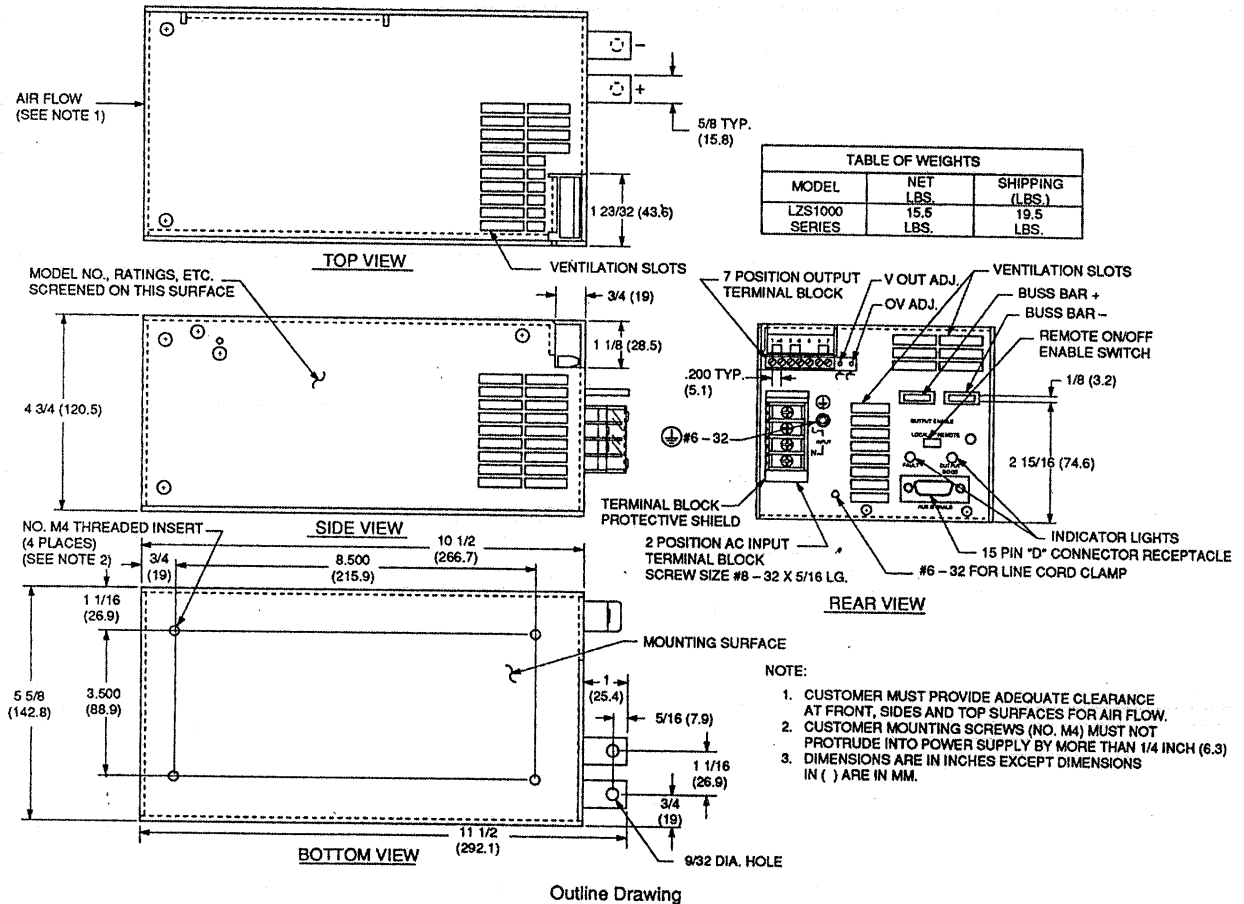

FIGURE 7: SERIES OPERATION

LZS SERIES INSTRUCTION MANUAL



LAMBDA ELECTRONICS INCORPORATED
 3055 DEL SOL BOULEVARD, SAN DIEGO, CA. 92154-3474 TEL:619-575-4400 FAX:619-575-7185