

PART NUMBER: VSCP-2K4 series

DESCRIPTION: switching power supply

features

- current sharing capability
- 0.98 typical power factor
- programmable output voltage
- universal AC input
- short circuit, overload, over voltage, over temperature protected
- forced air cooling by built-in DC fan
- power failure signal
- built-in remote sense
- built-in remote inhibit



model	output ¹	output current		max. power	regulation	ripple & noise ³		efficiency
		minimum	maximum ²			(Vpp)		
VSCP-2K4-09	9 V	0 A	133A / 226 A	2400 W	+/- 1%	1%	83%	
VSCP-2K4-12	12 V	0 A	100A / 200 A	2400 W	+/- 1%	1%	84%	
VSCP-2K4-15	15 V	0 A	80A / 160 A	2400 W	+/- 1%	1%	85%	
VSCP-2K4-18	18 V	0 A	66A / 133.3 A	2400 W	+/- 1%	1%	86%	
VSCP-2K4-24	24 V	0 A	50A / 100 A	2400 W	+/- 1%	1%	88%	
VSCP-2K4-36	36 V	0 A	33A / 66.6 A	2400 W	+/- 1%	1%	88%	
VSCP-2K4-48	48 V	0 A	5A / 50 A	2400 W	+/- 1%	1%	89%	
VSCP-2K4-60	60 V	0 A	20A / 40 A	2400 W	+/- 1%	1%	90%	

notes:

- 1 output voltage is measured at output power connector.
- 2 maximum current is measured at 100-120V input / 200-240V input
- 3 ripple and noise is measured from 10 KHz to 20 MHz at output terminals with 0.1 μ F ceramic capacitor and a 22 μ F electrolytic capacitor in parallel.

INPUT

parameter	conditions/description	min	nom	max	units
input frequency		47		63	Hz
input voltage	100~120 / 200~240 VAC (see derating curve)	100		240	VAC
	(130~185 / 260~370 VDC) (see derating curve)	130		370	VDC
inrush current	peak measured at 230 VAC, cold start			180	A

PART NUMBER: VSCP-2K4 series

DESCRIPTION: switching power supply

OUTPUT

parameter	conditions/description	min	nom	max	units
hold-up time	full load at 230 VAC			12	mS
setup time	full load at 230 VAC			500	mS
rise time	full load at 230 VAC			50	mS
programming	output voltage programmable through external 0~5V control voltage on VCI. control voltage can also be obtained from VCO via a 470 KOhm pot. see application diagrams.	25		100	%
voltage adjustability	typical adjustment by potentiometer 25%-100% adjustment by 1-5Vdc external control	-7.5		+7.5	%
temp. coefficient	(0 to 50°C)	-0.04		+0.04	%/°C
remote sense	designated as (VS+) and (VS-). total voltage compensation for cable losses with respect to the main output.				
remote inhibit	designated as (INH), requires a low signal to inhibit the output.				
current sharing	designated as (PAR), use in parallel for forced current sharing function.				

PROTECTION CIRCUIT

parameter	conditions/description	min	nom	max	units
overload	current limiting 3 times (1.5", 3.0", 5.0"), then intelligent auto recovery before shutdown				
overvoltage		110		135	%

GENERAL AND SAFETY

parameter	conditions/description	min	nom	max	units
operating temp.		0		50	°C
operating humid.		20%		90%	RH
storage temp.		-20		85	°C
storage humid.		10		95%	RH
vibration	period of 60 min. for each axis	10		200	Hz
EMC	EN55022, EN61000-4-2,3,4,5,6,8,11, EN61000-3-2-3 ENV50204				
safety regulation	approved to UL/cUL 1950, TUV EN60950				
leakage current	at 240 VAC			10.5	mA

MECHANICAL

parameter	conditions/description	min	nom	max	units
weight			8.9		Kg
enclosure	332(L) x 212(W) x 123.9(H)				mm

LOGIC CONNECTOR

parameter	conditions/description
pin assignments:	1. INH - remote on-off / remote inhibit 2. GND - return / output ground 3. PAR - current sharing / parallel function 4. PG - power good signal 5. VCO - reference output voltage (5-10 VDC) to be used for output programming 6. VCI - command input voltage for output programming 7. VS(-) - remote sense (-) 8. VS(+) - remote sense (+)

PART NUMBER: VSCP-2K4 series

DESCRIPTION: switching power supply

WIRING CONFIGURATIONS

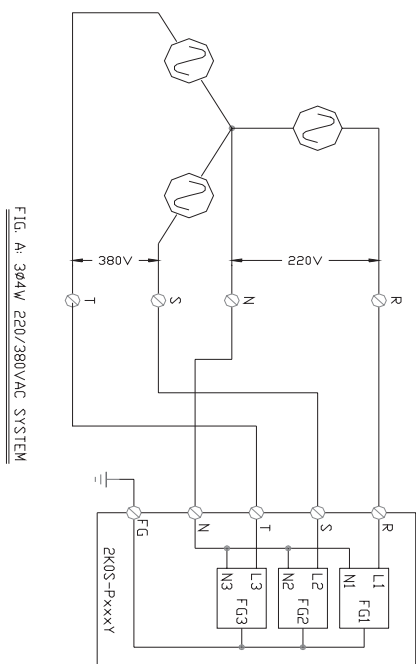

Optional

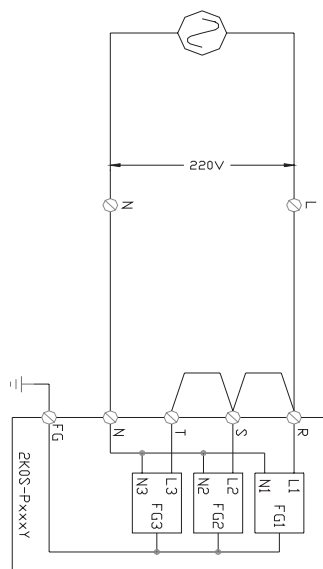

Standard

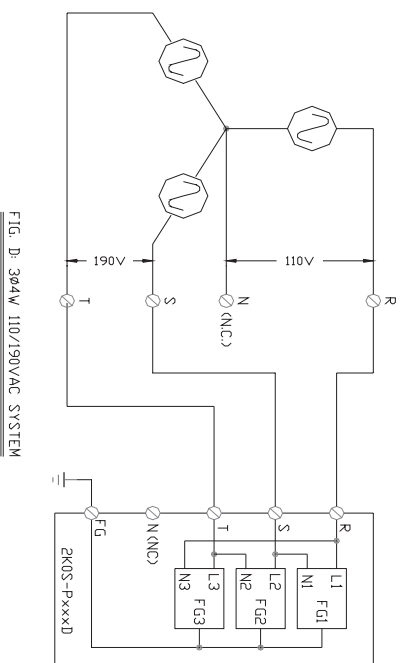

Optional

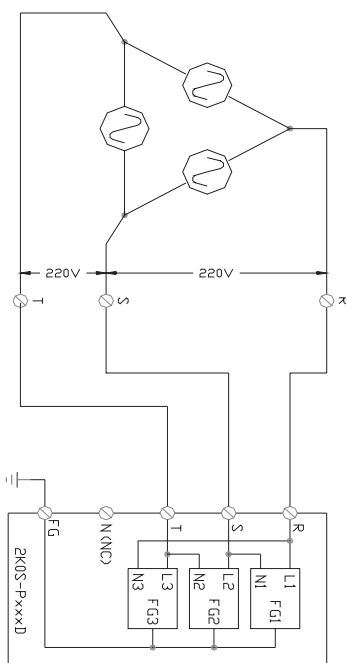

Optional

Wiring Configurations

PART NUMBER: VSCP-2K4 series

DESCRIPTION: switching power supply

LOGIC CONNECTIONS

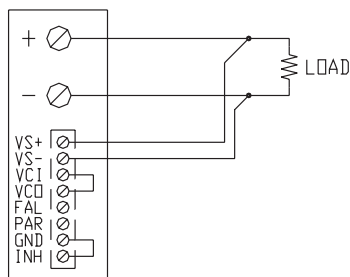

REMOTE SENSING

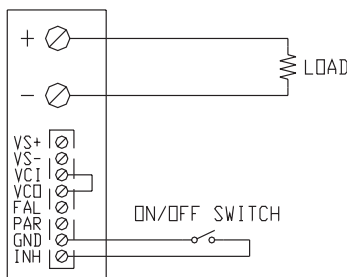

ON/OFF CONTROL BY SWITCH

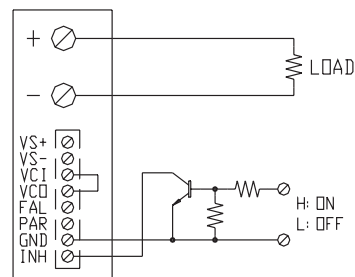

ON/OFF CONTROL BY TRANSISTOR

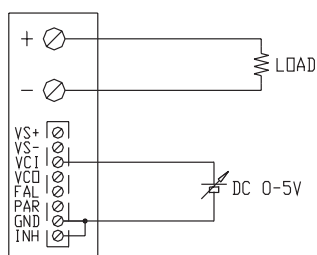

OUTPUT VOLTAGE ADJUST WITH DC 0-5V

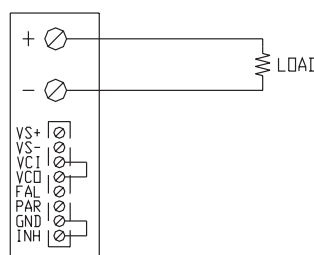

USING INTERNAL VOLTAGE CONTROL

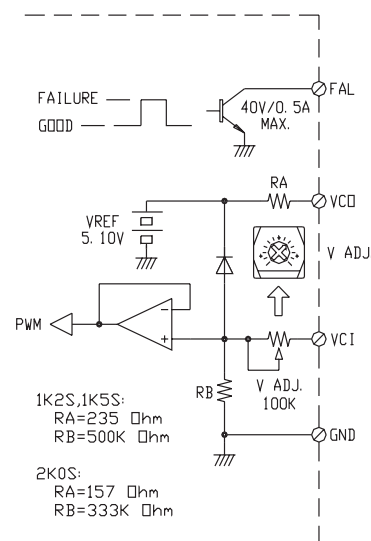

VCI AND VCD SIGNAL

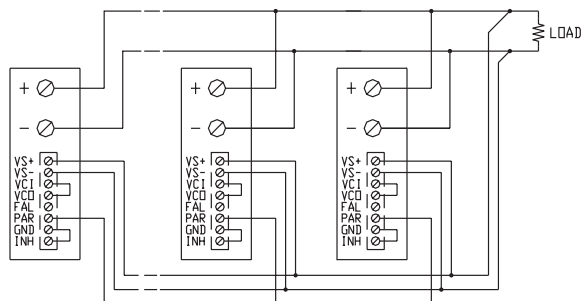

PARALLEL OPERATION WITH REMOTE SENSING

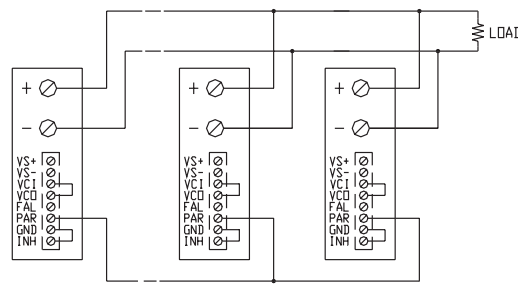

PARALLEL OPERATION WITHOUT REMOTE SENSING

PART NUMBER: VSCP-2K4 series

DESCRIPTION: switching power supply

MECHANICAL DRAWING

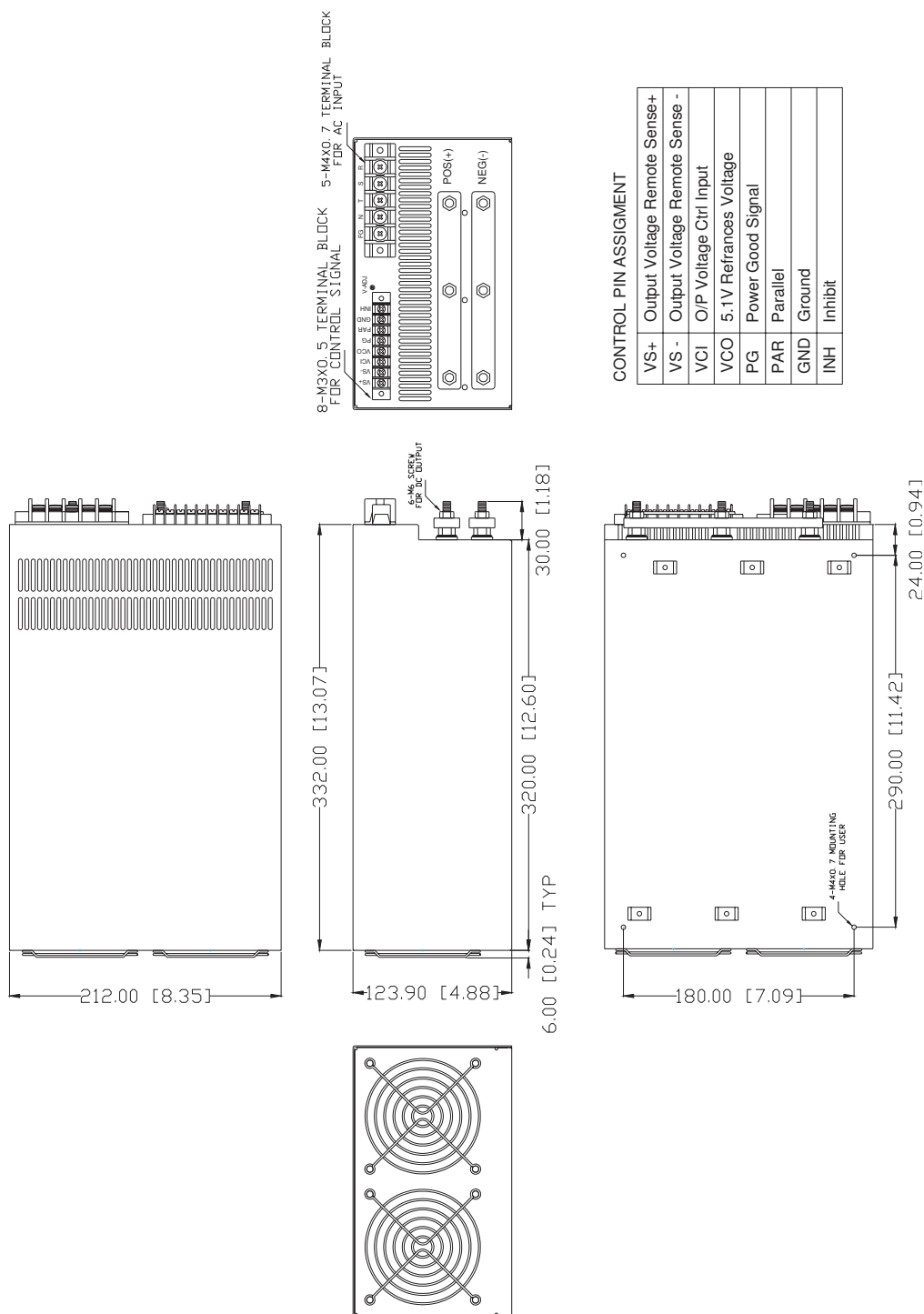

PART NUMBER: VSCP-2K4 series

DESCRIPTION: switching power supply

DERATING CURVES

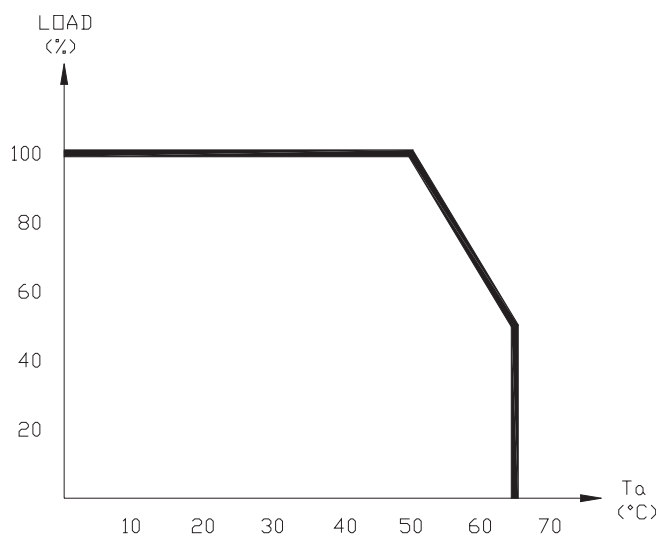

load derating curve

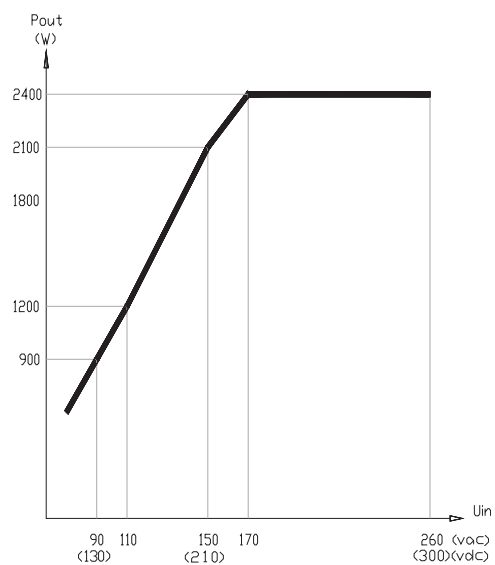

output power vs. input voltage derating curve