

Switch Mode Power Supply S8PS (50/100/150/300/600-W Models)

Compact DIN Rail-mounting Power Supplies

- Complies with EN 61000-3-2 harmonic current standards.
- Safety standards: UL, CSA, and EN/VDE.
- Complies with EN 61204-3 Class B.
- Mounting Bracket included for front mounting or DIN Rail mounting.
- RoHS-compliant

Note: Refer to *Safety Precautions* on page 12.



Model Number Structure

Model Number Legend

Note: Not all combinations are possible. Refer to *List of Models* in *Ordering Information*, below.

S8PS-□□□□□□
 1 2 3

1. Power Ratings

050: 50 W
100: 100 W
150: 150 W
300: 300 W
600: 600 W

2. Output Voltage

05: 5 V
12: 12 V
24: 24 V

3. Configuration

C: Covered type with Front Mounting Bracket
D: Open-frame type with DIN Rail Mounting Bracket
CD: Covered type with DIN Rail Mounting Bracket
None: Open-frame type with Front Mounting Bracket

Ordering Information

List of Models

Note: For details on normal stock models, contact your nearest OMRON representative.

Configuration	Input voltage	Power ratings	Output voltage	Output current	Front-mounting Model	DIN Rail-mounting Model	
Covered type	100 to 240 VAC	50 W	5 V	10 A	S8PS-05005C	S8PS-05005CD	
			12 V	4.2 A	S8PS-05012C	S8PS-05012CD	
			24 V	2.1 A	S8PS-05024C	S8PS-05024CD	
		100 W	24 V	4.5 A	S8PS-10024C	S8PS-10024CD	
			150 W	24 V	6.5 A	S8PS-15024C	S8PS-15024CD
				300 W	24 V	14 A	S8PS-30024C
600 W	24 V	27 A	S8PS-60024C	---			
	Open-frame type	100 to 240 VAC	50 W	5 V	10 A	S8PS-05005	S8PS-05005D
12 V				4.2 A	S8PS-05012	S8PS-05012D	
24 V				2.1 A	S8PS-05024	S8PS-05024D	
100 W			24 V	4.5 A	S8PS-10024	S8PS-10024D	
			150 W	24 V	6.5 A	S8PS-15024	S8PS-15024D

Options (Order Separately)

Name	Model
Fan	S82Y-JFAN

Specifications

■ Ratings/Characteristics

Item		50 W	100 W	150 W	300 W	600 W	
Efficiency (typical)		74% to 80% (depends on the model)					
Input	Voltage (See note 1.)	100 to 240 VAC (85 to 264 VAC)					
	Frequency (See note 1.)	50/60 Hz (47 to 63 Hz)					
	Current (See note 2.)	100-V input	0.9 A max.	1.8 A max.	2.7 A max.	5.4 A max.	10 A max.
		200-V input	0.45 A max.	0.9 A max.	1.4 A max.	2.7 A max.	5 A max.
	Leakage current (See note 2.)	100-V input	0.5 mA max.				
		200-V input	1.0 mA max.				
	Inrush current (See note 2.)	100-V input	25 A max. (for a cold start at 25°C)				
		200-V input	50 A max. (for a cold start at 25°C)				
Power factor (See note 2.)	0.95 typical						
Harmonic current standards	Based on EN 61000-3-2		Complies with EN 61000-3-2				
Output	Voltage adjustment range (See note 3.)	-5% to 10%					
	Ripple (See note 2.)	2% (p-p) max.					
	Input variation influence	0.4% max. (at 85 to 132 VAC input/at 170 to 264 VAC input, 100% load)					
	Load variation influence	0.8% max. (with rated input, 0 to 100% load)					
	Temperature variation influence (See note 2.)	0.05%/°C max.					
	Startup time	1,000 ms max. (up to 90% of output voltage at rated output voltage/current)				1,500 ms max.	
	Hold time (See note 2.)	20 ms min.					
	Additional function	Overload protection	105% min., voltage drop, intermittent operation (With the 600-W model, output is turned OFF at 5 s min.)				
Overvoltage protection (See note 5.)		Yes					
Overheat protection		No				Yes	
Protection-ON alarm indicator		No				Yes (color: red)	
Parallel operation		No				Yes, 2 units max.	
Other	Heat radiation	Natural air-cooling				Built-in fan	
	Ambient operating temperature	Refer to the derating curve in <i>Engineering Data</i> (with no icing or condensation).					
	Storage temperature	-25 to 65°C					
	Ambient operating humidity	25% to 85%					
	Dielectric strength	3.0 kVAC for 1 min. (between all inputs and outputs)					
		2.2 kVAC for 1 min. (between all inputs and PE terminal)					
		1.0 kVAC for 1 min. (between all outputs and PE terminal)					
	Insulation resistance	100 MΩ min. (between all outputs and inputs/PE terminal at 500 VDC)					
	Vibration resistance	10 to 55 Hz, 0.75-mm amplitude for 2 h each in X, Y, and Z directions					
	Shock resistance	300 m/s ² , 3 times each in ±X, ±Y, and ±Z directions					
	Output indicator	Yes (color: green)					
	EMI	Conducted Emission (See note 2.)	Conforms to EN61204-3 EN55011 Class B and based on FCC Class B				
			Conforms to EN61204-3 EN55011 Class B				
	EMS	Conforms to EN61204-3 High severity levels					
	Approved standards	UL cUL cUR EN/VDE	UL508, UL1012, UL60950-1 CSA C22.2 No. 14 CSA No. 60950-1 EN50178 (=VDE0160), EN60950-1 (=VDE0805 Teil 1)				
Weight (See note 6.)			420 g max.	600 g max.	735 g max.	2,200 g max.	3,500 g max.
Mounting method		Front Mounting Bracket or DIN Rail Mounting Bracket				Front Mounting Bracket	

Note: 1. Do not use an inverter output for the Power Supply. Inverters with an output frequency of 50/60 Hz are available, but the rise in the internal temperature of the Power Supply may result in ignition or burning.

2. A 100% load for rated input voltage (100 VAC or 200 VAC).
3. If the output voltage adjuster (V. ADJ) is turned, the voltage will increase by more than 10% of the voltage adjustment range. When adjusting the output voltage, confirm the actual output voltage from the Power Supply and be sure that the load is not damaged.
4. The output will shut off and the protection-ON alarm indicator will simultaneously light. Turn OFF the input power supply, wait 1 min., and then turn ON the input power supply to recover normal operation.
5. Turn OFF the input power supply, wait 1 min., and then turn ON the input power to recover normal operation. (For 300-W and 600-W models, the output will shut off and the protection-ON indicator will simultaneously light.)
6. The weight indicated is for a front-mounting open-frame model. (includes the cover for 300-W and 600-W front-mounting models.)

Connections

■ Block Diagrams

S8PS-050□□□□ (50 W)

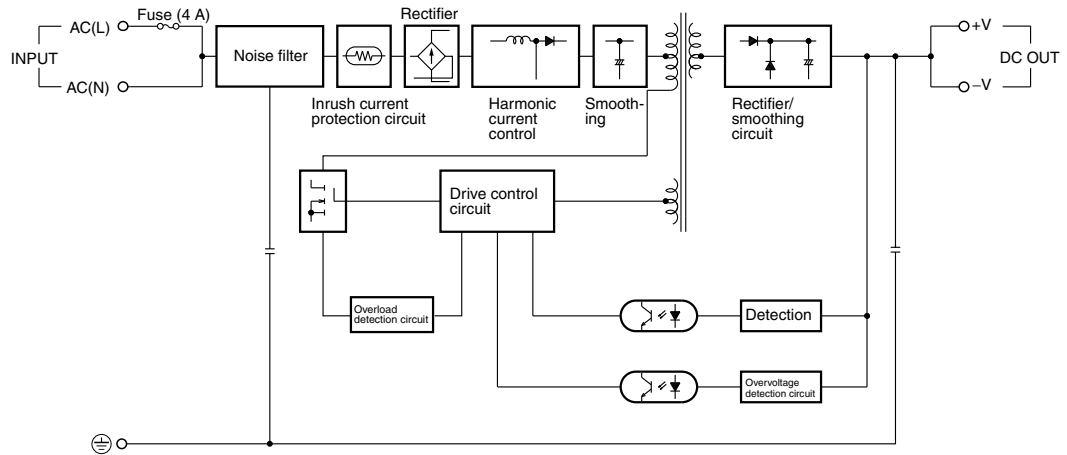

S8PS-10024□□ (100 W)

S8PS-15024□□ (150 W)

S8PS-30024□□ (300 W)

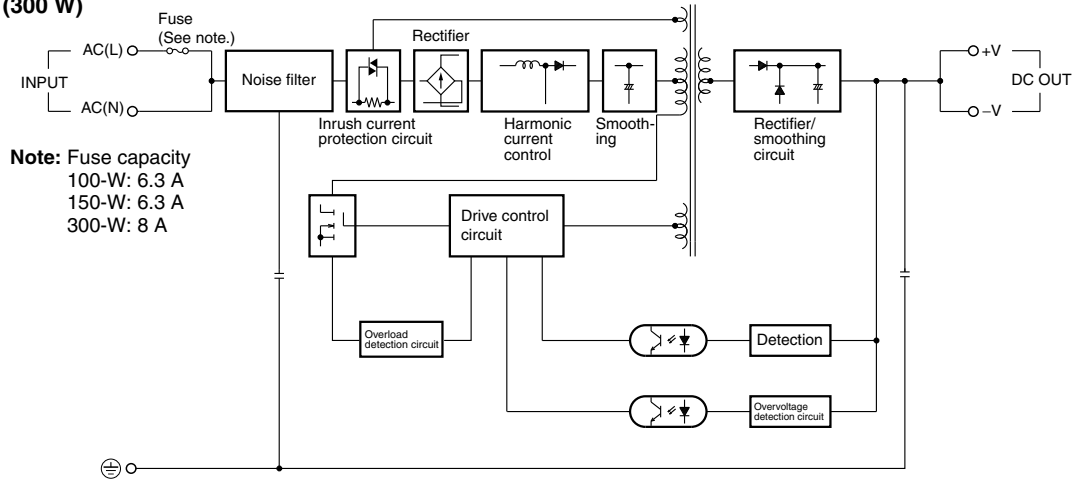

S8PS-60024C (600 W)

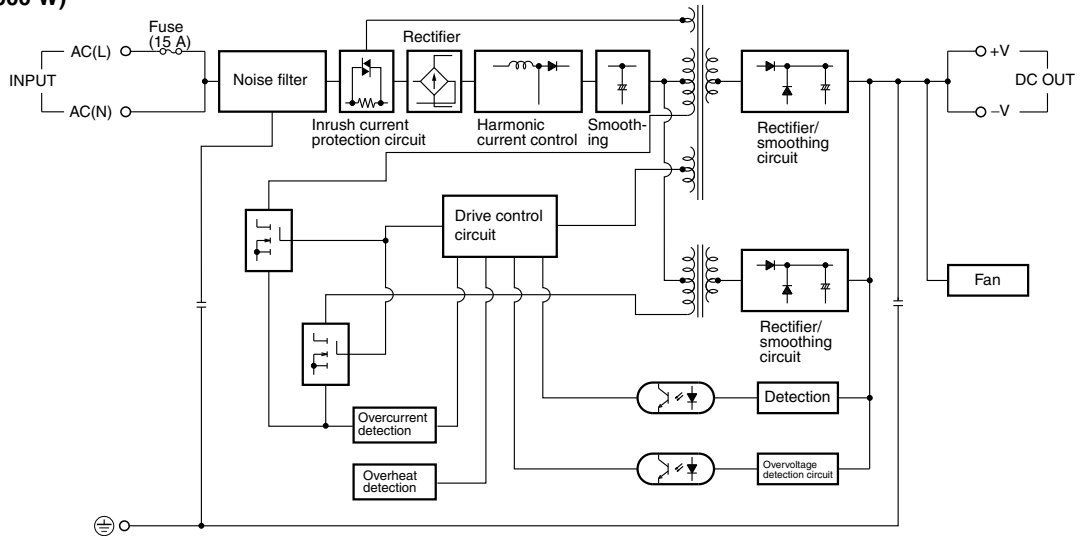

Construction and Nomenclature

■ Nomenclature

50-W Models

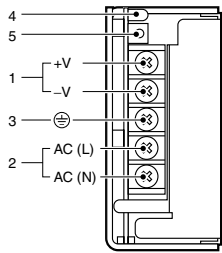

100-/150-W Models

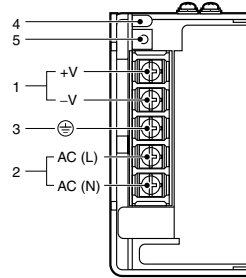

300-W Models

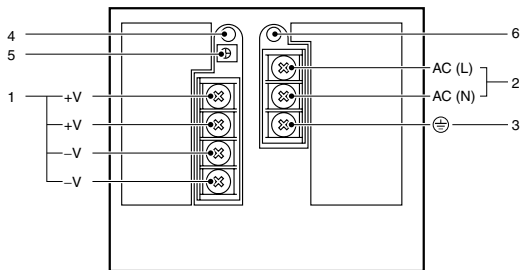

600-W Models

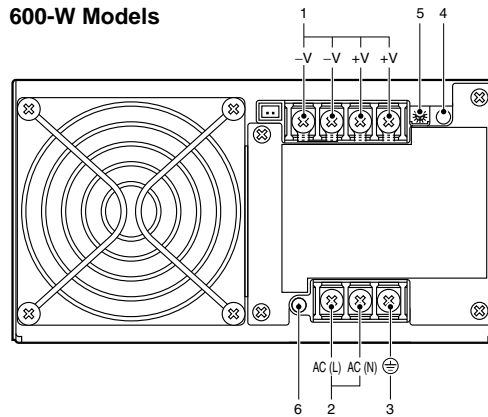

1. **DC Output Terminals (+V, -V):** Connect the load lines to these terminals.
2. **Input Terminals (L, N):** Connect the input lines to these terminals.
Note: A fuse is located on the (L) side. It is NOT user replaceable.
3. **Protective Earthing Terminal (⊖) :** Connect a ground line to this terminal.
4. **Output Indicator (DC ON: Green):** Lights (green) while a direct current (DC) output is ON.
5. **Output Voltage Adjuster (V.ADJ):** It is possible to increase or decrease the output voltage by -5% to +10%.
6. **Protection-ON Alarm Indicator (Red):** The red indicator will be lit if the overvoltage (for a 300-/600-W model) or overheat protection (for a 600-W model) circuit is triggered. This indicator will also be lit when overcurrent (for a 600-W model) is detected.

Engineering Data

Derating Curve (Standard Installation)

Open-frame Type

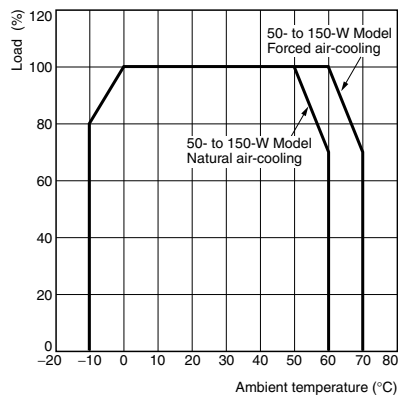

Covered Type

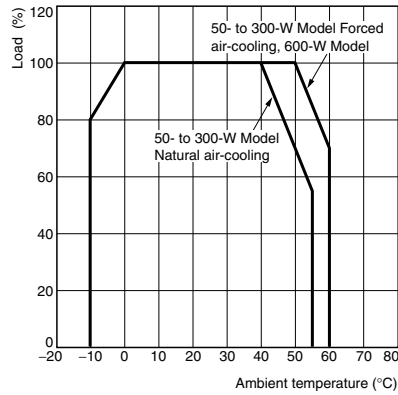

Standard Installation (50-W Model)

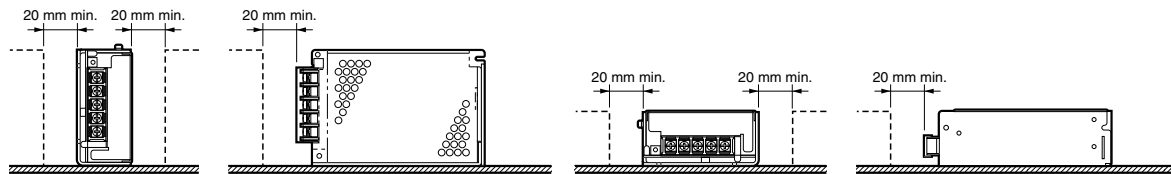

Standard Installation (100/150-W Model)

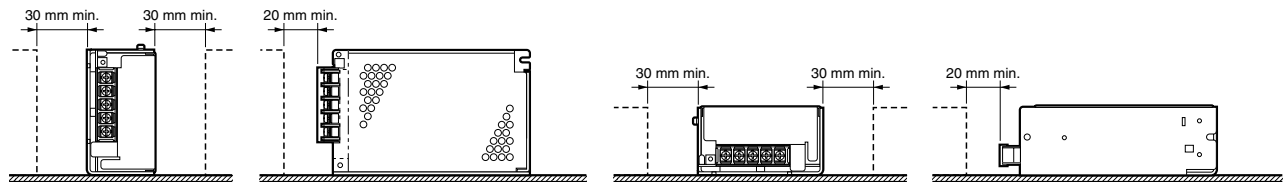

Standard Installation (300-W Model)

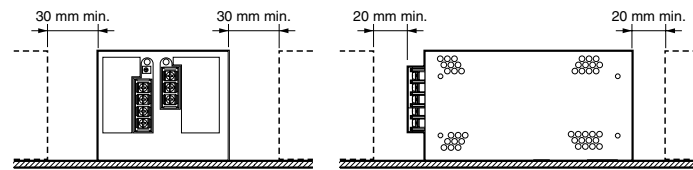

Standard Installation (600-W Model)

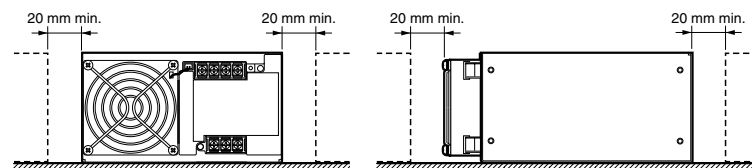

- Note:**
1. Forced air-cooling must be provided with an air volume of 1 m³/mm min.
 2. The derating curve shown is for standard installation. The derating curve depends on the mounting direction of the Power Supply.

Overload Protection

50- to 300-W Models

The Power Supply is provided with an overload protection function that protects the power supply from possible damage from an overload. The protection function operates when the load current rises above an overcurrent detection value (105% of the rated load current except for 300-W models, for which the value is 101%). For a short-circuit or overload lasting less than 20 seconds, output voltage is decreased to protect equipment. When the output current falls within the rated range, the overload protection function is automatically cleared.

50-, 100-, 150-W Models

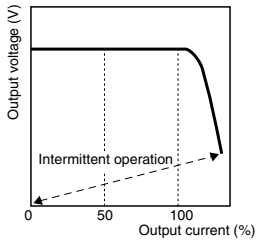

300-W Model

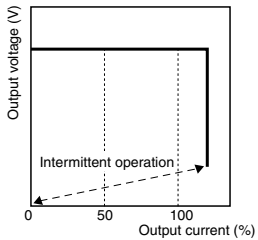

The values shown in the above diagrams are for reference only.

Note: If a short-circuit or overload lasts 20 seconds or longer, internal circuits may deteriorate or be damaged.

600-W Model

If the overload state continues for 5 seconds or longer, the output will shut off and the protection-ON alarm indicator will simultaneously light. Reset the input power by turning it OFF for at least one minute and then turning it back again.

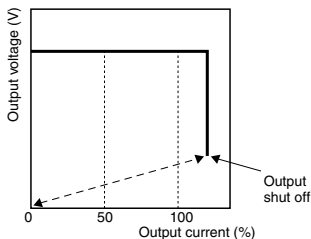

Note: Internal parts may occasionally deteriorate or be damaged if a short-circuited or other overcurrent state continues during operation.

Overvoltage Protection

The Power Supply is provided with an overvoltage protection function that protects the Power Supply from possible damage by overvoltage. When the output voltage rises above a set value (115% of the rated output voltage), the protection function is triggered, shutting OFF the output voltage. Reset the input power by turning it OFF for at least one minute and then turning it back again.

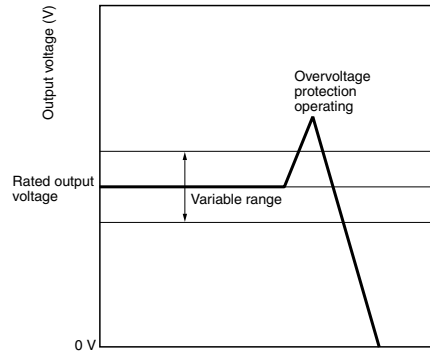

The values shown in the above diagram are for reference only.

300- and 600-W Models

If more than approx. 115% of the rated output voltage is output, the output will be shut off and simultaneously the protection-ON alarm indicator will light. Reset the input power by turning it OFF for at least one minute and then turning it back again.

Overheat Protection Function

600-W Model Only

If the internal temperature of the S8PS rises excessively as a result of fan failure or any other reason, the overheat protection circuit will be triggered to protect the internal parts of the S8PS and simultaneously a protection-ON alarm indicator will be lit. Reset the input power by turning it OFF for at least one minute and then turning it back again.

Inrush Current, Startup Time, Hold Time

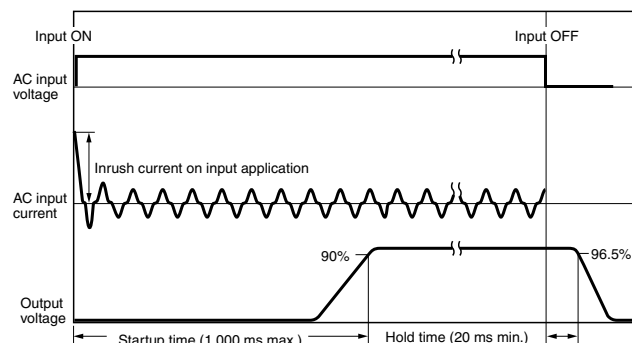

Dimensions

Note: All units are in millimeters unless otherwise indicated.

■ Front-mounting Models

S8PS-050□□ (50 W)
S8PS-050□□C (50 W)

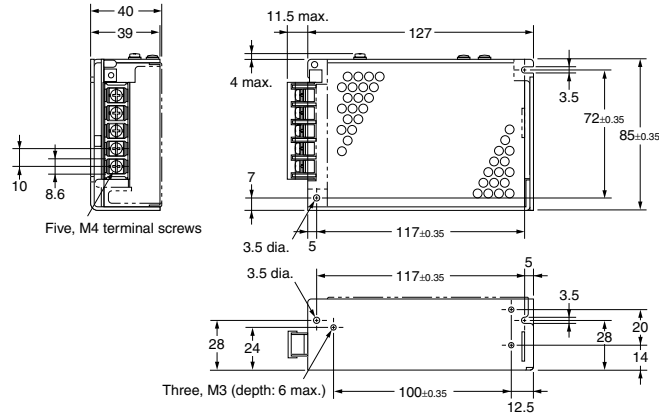
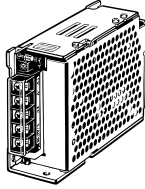

Mounting Holes

Front Screw Mounting	
Side Mounting	Two, M3 72±0.35 117±0.35
Bottom Mounting	Two, M3 117±0.35

S8PS-10024 (100 W)
S8PS-10024C (100 W)

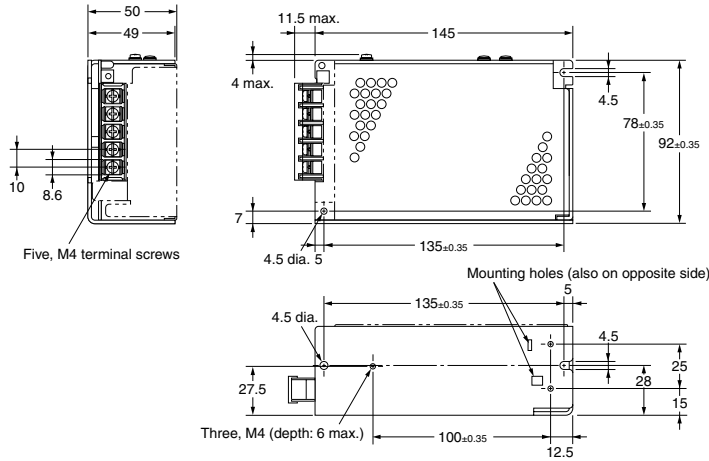
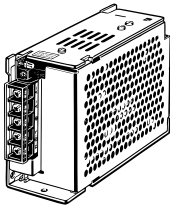

Mounting Holes

Front Screw Mounting	
Side Mounting	Two, M4 78±0.35 135±0.35
Bottom Mounting	Two, M4 135±0.35

S8PS-15024 (150 W)
S8PS-15024C (150 W)

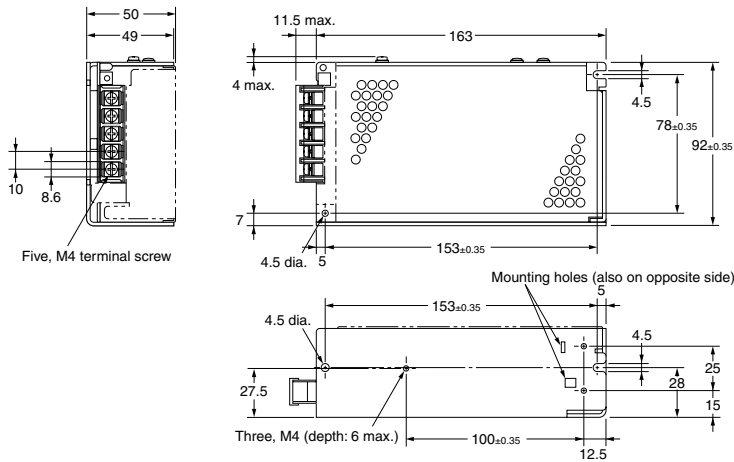
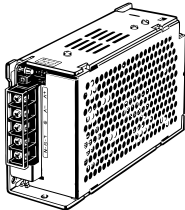

Mounting Holes

Front Screw Mounting	
Side Mounting	Two, M4 78±0.35 153±0.35
Bottom Mounting	Two, M4 153±0.35

S8PS-30024C (300 W)

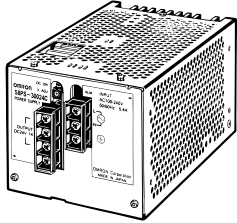
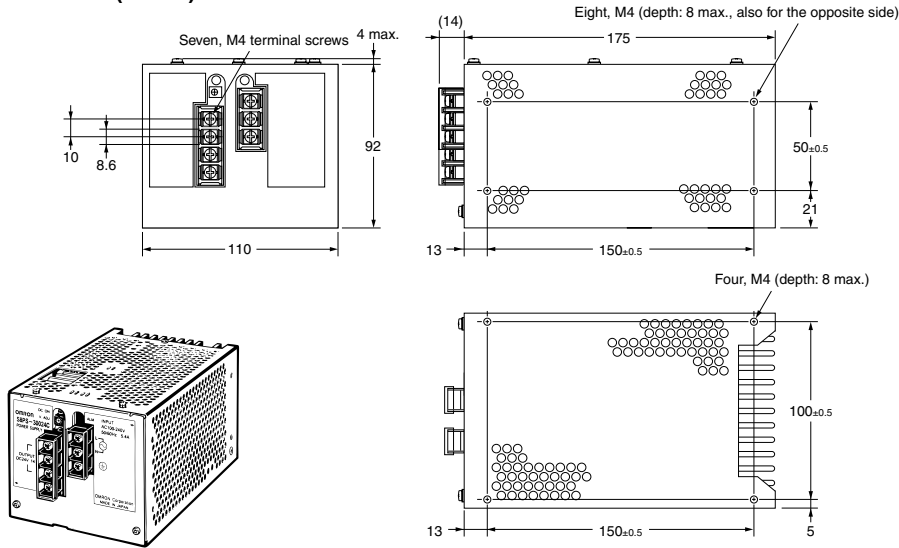

Mounting Holes

Front Screw Mounting	
Side Mounting	Four, 4.5 dia. 50±0.5 150±0.5
Bottom Mounting	Four, 4.5 dia. 100±0.5 150±0.5

S8PS-60024C(600 W)

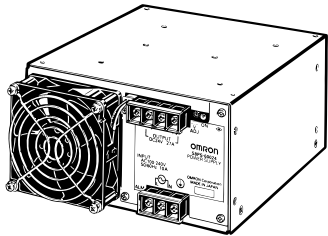
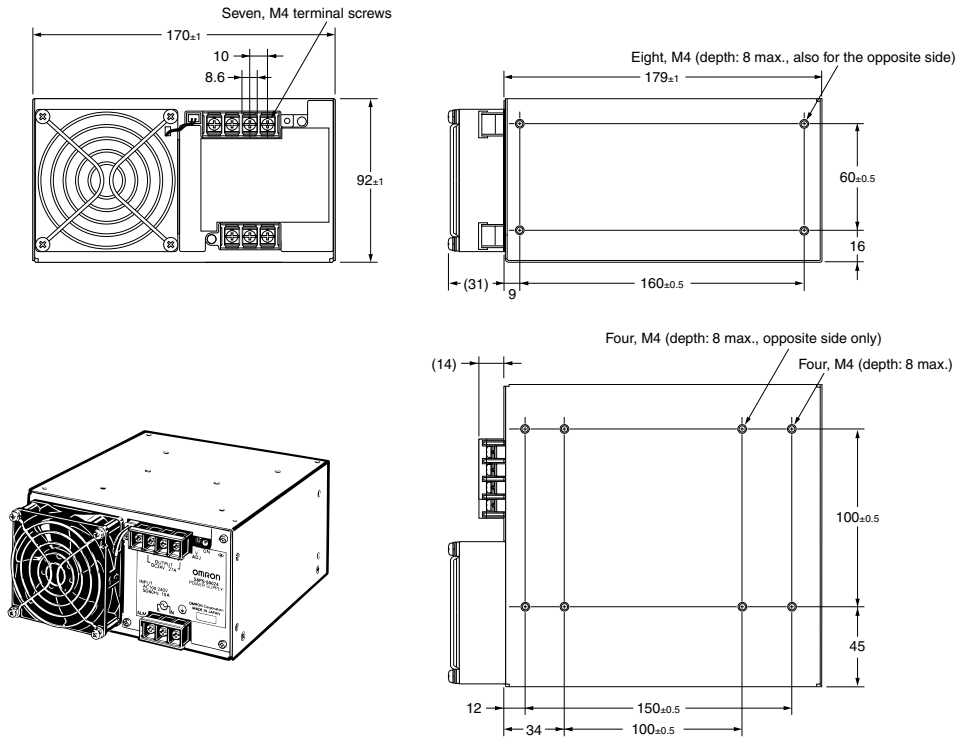

Mounting Holes

Front Screw Mounting	
Side Mounting	Four, 4.5 dia. 60±0.5 160±0.5
Bottom Mounting	Four, 4.5 dia. 100±0.5 150±0.5

■ Front Mounting Brackets

Note: Screws for fixing the Bracket to the panel are not provided.

Front Mounting Bracket for 50-W Models

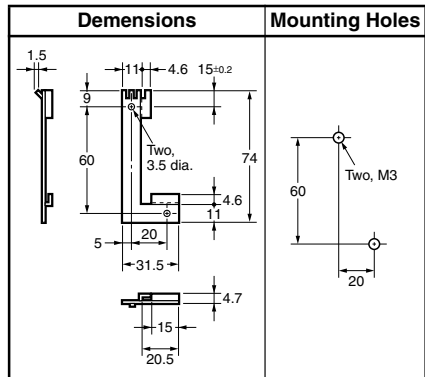

Using the Mounting Bracket

Attach the Mounting Bracket to the panel and loosely tighten the two screws. Insert the projected parts of the Bracket (b) to the square holes of the power supply (a). Then securely tighten the screws.

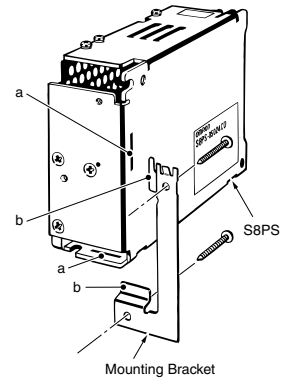

Front Mounting Bracket for 100/150-W Models

Appearance and Mounting Dimensions

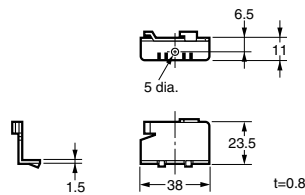

Dimensions with Mounting Bracket

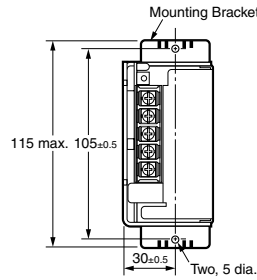

Using the Mounting Bracket

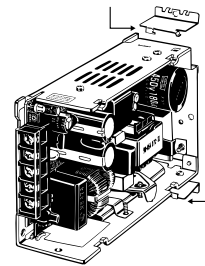

Front Mounting Bracket for 300/600-W Models

Appearance and Mounting Dimensions

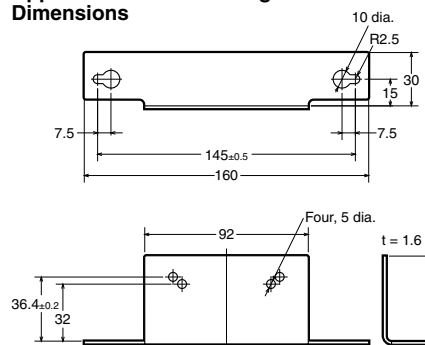

Dimensions with Mounting Bracket 300-W Models

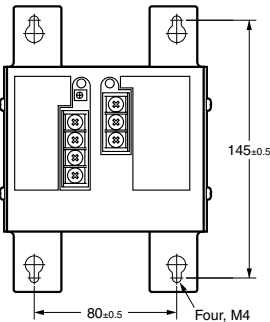

Using the Mounting Bracket

300-W Models

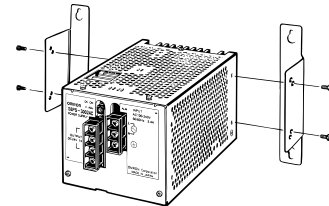

Note: Mount the Unit 21.6 mm away from the mounting surface in order to provide air ventilation on the rear side.

600-W Models

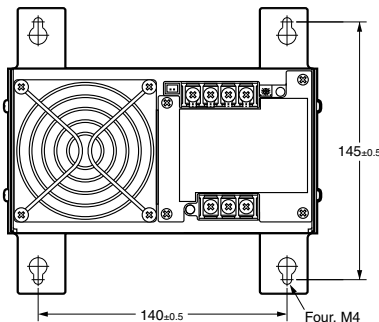

600-W Models

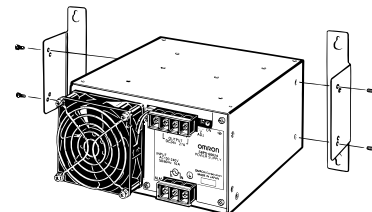

Note: Mount the Unit 28 mm away from the mounting surface in order to provide air ventilation on the rear side.

■ DIN Rail-mounting Models

S8PS-050□□D (50 W)
S8PS-050□□CD (50 W)

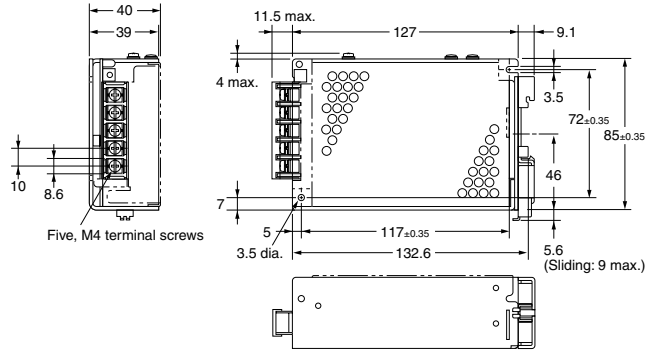
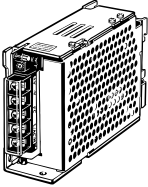

S8PS-10024D (100 W)
S8PS-10024CD (100 W)

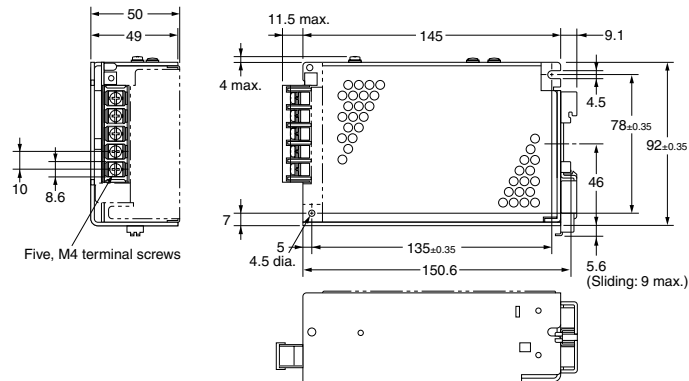
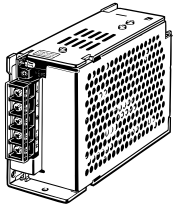

S8PS-15024D (150 W)
S8PS-15024CD (150 W)

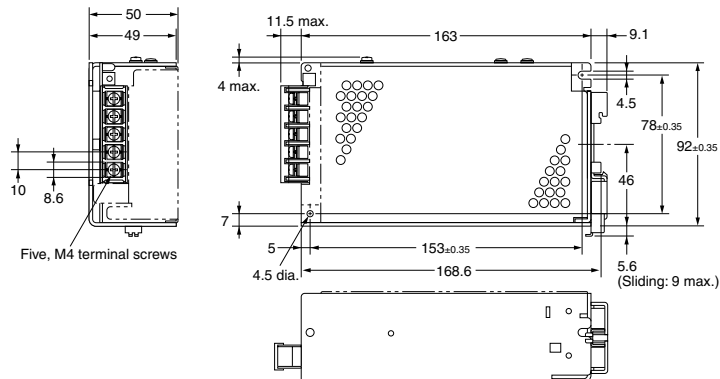
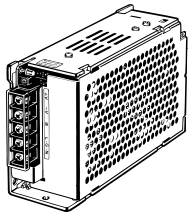

S8PS-30024CD (300 W)

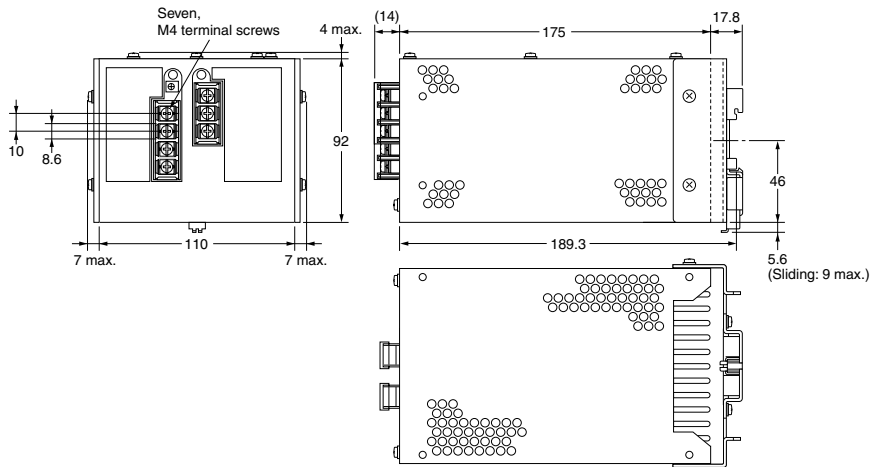
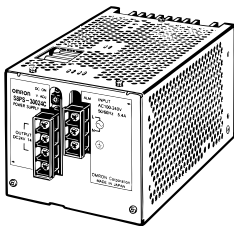

■ Accessories

Mounting Rail (Order Separately)

PFP-100N
PFP-50N

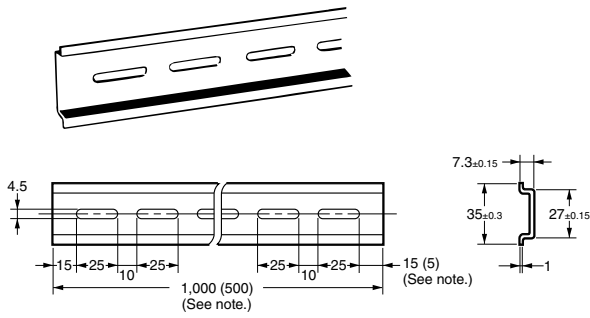

PFP-100N2

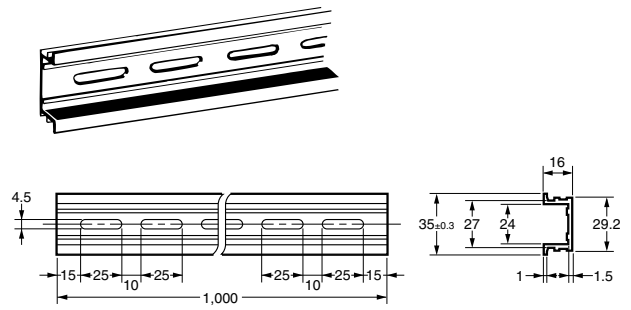

Note: The values shown in parentheses are for the PFP-50N.

Safety Precautions

CAUTION

Minor electric shock, fire, or Product failure may occasionally occur. Do not disassemble, modify, or repair the Product or touch the interior of the Product.



Minor burns may occasionally occur. Do not touch the Product while power is being supplied or immediately after power is turned OFF.



Fire may occasionally occur. Tighten terminal screws to the specified torque 1.08 N·m (M4).



Electric shock due to residual voltage may occur. Do not touch the Product for at least 1 minute after the input power is turned OFF.



Minor electric shock, fire, or Product failure may occasionally occur. Do not allow any pieces of metal or conductors or any clippings or cuttings resulting from installation work to enter the Product.



Precautions for Safe Use

Mounting

To improve and maintain the reliability of the Power Supply over a long period of time, adequate consideration must be given to heat radiation.

The Power Supply is designed to radiate heat by means of natural air-flow. Therefore, mount the Power Supply so that air flow takes place around the Power Supply.

Use a metal plate as the mounting panel.

Forced air-cooling is highly recommended.

Wiring

Connect the ground completely. Electric shock may occur if the ground is not connected completely.

Do not apply more than 75-N force to the terminal block when tightening it.

Buzzing Noise When the Input Is Turned ON

A harmonic current suppression circuit is built into the input power. This circuit can create noise when the input is turned ON, but it will last only until the internal operation stabilizes and does not indicate any problem in the Power Supply.

Generating Output Voltage (\pm)

An output of \pm can be generated by using two Power Supplies as shown below, because the Power Supply produces a floating output.

Correct

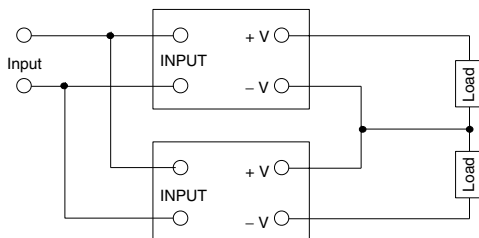

Series Operation

All models allow series operation.

As shown in the following diagram, the output voltage from each Switching Power Supply can be added.

Correct

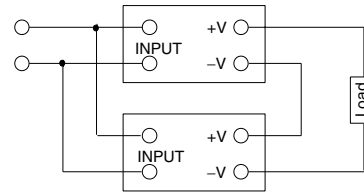

Parallel Operation

Only 300- and 600-W models can be in parallel operation. Do not operate any other models in parallel. (A maximum of two Power Supplies can be used in parallel operation and they must have the same model number.)

Make sure that the thickness and the length of all wires connected to the load are the same to ensure that the wires will have no voltage drop differences.

Correct

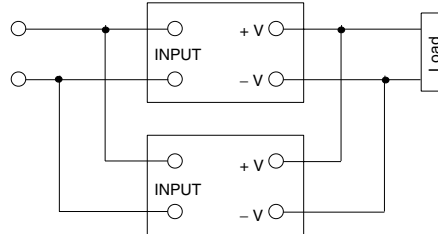

Fan Replacement

The service life of the fan is approximately 50,000 hours (at 25°C). The service life varies, however, depending on the ambient temperature or other surrounding environmental conditions such as dust. As a preventive maintenance measure, replace the fan within two years if it is used at an ambient temperature of 40°C.

Fans are available as replacements.

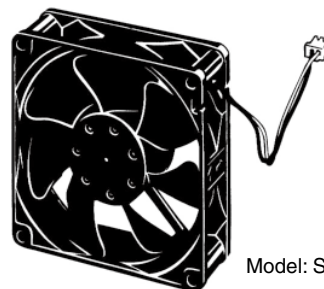

Model: S82Y-JFAN

Fan Set:

Fan (above), four M4 x 35 sems screws, instruction sheet, and packing case

Replace the fan as shown in the following illustration.

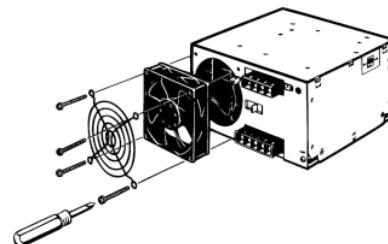

ALL DIMENSIONS SHOWN ARE IN MILLIMETERS.

To convert millimeters into inches, multiply by 0.03937. To convert grams into ounces, multiply by 0.03527.

In the interest of product improvement, specifications are subject to change without notice.

Read and Understand This Catalog

Please read and understand this catalog before purchasing the products. Please consult your OMRON representative if you have any questions or comments.

Warranty and Limitations of Liability

WARRANTY

OMRON's exclusive warranty is that the products are free from defects in materials and workmanship for a period of one year (or other period if specified) from date of sale by OMRON.

OMRON MAKES NO WARRANTY OR REPRESENTATION, EXPRESS OR IMPLIED, REGARDING NON-INFRINGEMENT, MERCHANTABILITY, OR FITNESS FOR PARTICULAR PURPOSE OF THE PRODUCTS. ANY BUYER OR USER ACKNOWLEDGES THAT THE BUYER OR USER ALONE HAS DETERMINED THAT THE PRODUCTS WILL SUITABLY MEET THE REQUIREMENTS OF THEIR INTENDED USE. OMRON DISCLAIMS ALL OTHER WARRANTIES, EXPRESS OR IMPLIED.

LIMITATIONS OF LIABILITY

OMRON SHALL NOT BE RESPONSIBLE FOR SPECIAL, INDIRECT, OR CONSEQUENTIAL DAMAGES, LOSS OF PROFITS, OR COMMERCIAL LOSS IN ANY WAY CONNECTED WITH THE PRODUCTS, WHETHER SUCH CLAIM IS BASED ON CONTRACT, WARRANTY, NEGLIGENCE, OR STRICT LIABILITY.

In no event shall responsibility of OMRON for any act exceed the individual price of the product on which liability is asserted.

IN NO EVENT SHALL OMRON BE RESPONSIBLE FOR WARRANTY, REPAIR, OR OTHER CLAIMS REGARDING THE PRODUCTS UNLESS OMRON'S ANALYSIS CONFIRMS THAT THE PRODUCTS WERE PROPERLY HANDLED, STORED, INSTALLED, AND MAINTAINED AND NOT SUBJECT TO CONTAMINATION, ABUSE, MISUSE, OR INAPPROPRIATE MODIFICATION OR REPAIR.

Application Considerations

SUITABILITY FOR USE

OMRON shall not be responsible for conformity with any standards, codes, or regulations that apply to the combination of products in the customer's application or use of the product.

At the customer's request, OMRON will provide applicable third party certification documents identifying ratings and limitations of use that apply to the products. This information by itself is not sufficient for a complete determination of the suitability of the products in combination with the end product, machine, system, or other application or use.

The following are some examples of applications for which particular attention must be given. This is not intended to be an exhaustive list of all possible uses of the products, nor is it intended to imply that the uses listed may be suitable for the products:

- Outdoor use, uses involving potential chemical contamination or electrical interference, or conditions or uses not described in this catalog.
- Nuclear energy control systems, combustion systems, railroad systems, aviation systems, medical equipment, amusement machines, vehicles, safety equipment, and installations subject to separate industry or government regulations.
- Systems, machines, and equipment that could present a risk to life or property.

Please know and observe all prohibitions of use applicable to the products.

NEVER USE THE PRODUCTS FOR AN APPLICATION INVOLVING SERIOUS RISK TO LIFE OR PROPERTY WITHOUT ENSURING THAT THE SYSTEM AS A WHOLE HAS BEEN DESIGNED TO ADDRESS THE RISKS, AND THAT THE OMRON PRODUCT IS PROPERLY RATED AND INSTALLED FOR THE INTENDED USE WITHIN THE OVERALL EQUIPMENT OR SYSTEM.

Disclaimers

CHANGE IN SPECIFICATIONS

Product specifications and accessories may be changed at any time based on improvements and other reasons.

It is our practice to change model numbers when published ratings or features are changed, or when significant construction changes are made. However, some specifications of the product may be changed without any notice. When in doubt, special model numbers may be assigned to fix or establish key specifications for your application on your request. Please consult with your OMRON representative at any time to confirm actual specifications of purchased product.

DIMENSIONS AND WEIGHTS

Dimensions and weights are nominal and are not to be used for manufacturing purposes, even when tolerances are shown.

ERRORS AND OMISSIONS

The information in this catalog has been carefully checked and is believed to be accurate; however, no responsibility is assumed for clerical, typographical, or proofreading errors, or omissions.

PERFORMANCE DATA

Performance data given in this catalog is provided as a guide for the user in determining suitability and does not constitute a warranty. It may represent the result of OMRON's test conditions, and the users must correlate it to actual application requirements. Actual performance is subject to the OMRON Warranty and Limitations of Liability.

PROGRAMMABLE PRODUCTS

OMRON shall not be responsible for the user's programming of a programmable product, or any consequence thereof.

COPYRIGHT AND COPY PERMISSION

This catalog shall not be copied for sales or promotions without permission.

This catalog is protected by copyright and is intended solely for use in conjunction with the product. Please notify us before copying or reproducing this catalog in any manner, for any other purpose. If copying or transmitting this catalog to another, please copy or transmit it in its entirety.