

## Features

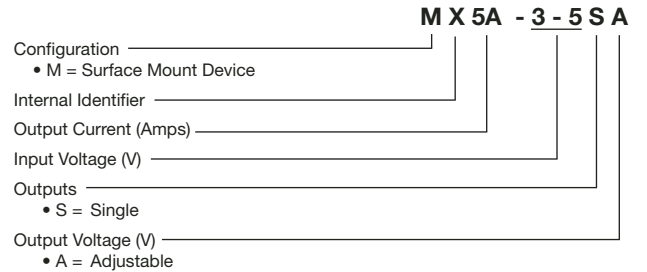
- Industry standard surface mount device
- RoHS compliant\*
- Output voltage programmable from 0.75 V<sub>dc</sub> to 3.3 V<sub>dc</sub> via external resistor
- Up to 5 A output current
- Up to 94 % efficiency
- Small size, low profile
- Cost-efficient open frame design
- Low output ripple and noise
- High reliability
- Remote on/off
- Output overcurrent protection (non-latching)
- Constant switching frequency (300 kHz)
- Wide operating temperature range

## MX5A-3-5SA SMT Non-Isolated Power Module

### Description

Bourns® MX5A-3-5SA is a non-isolated DC-DC converter offering designers a cost and space-efficient solution with standard features such as remote on/off, precisely regulated programmable output voltage and overcurrent and over-temperature protection. These modules deliver up to 5 A of output current with full load efficiency of 94 % at 3.3 V output.

### How to Order



Please contact your Bourns sales representative for pricing, availability and optional features.

### Absolute Maximum Ratings

Stress in excess of absolute maximum ratings may cause permanent damage to the device. Device reliability may be affected if exposed to absolute maximum ratings for extended time periods.

Characteristic	Min.	Max.	Units	Notes & Conditions
Continuous Input Voltage	-0.3	5.8	V <sub>dc</sub>	
Operating Temperature Range	-40	+85	°C	See Thermal Considerations section
Storage Temperature	-55	+125	°C	

### Electrical Specifications

Unless otherwise specified, specifications apply over all input voltage, resistive load and temperature conditions.

Characteristic	Min.	Nom.	Max.	Units	Notes & Conditions
Operating Input Voltage	3.0		5.5	V <sub>dc</sub>	V <sub>out</sub> ≤ V <sub>in</sub> - 0.5 V
Maximum Input Current	-		5.0	A <sub>dc</sub>	Over V <sub>in</sub> range, I <sub>o</sub> max, V <sub>out</sub> = 3.3 V <sub>dc</sub>
Input No Load Current		20 45		mA mA	V <sub>in</sub> = 5.0 V <sub>dc</sub> , I <sub>o</sub> = 0 A, mod. enabled, -V <sub>out</sub> = 0.75 V <sub>dc</sub> -V <sub>out</sub> = 3.3 V <sub>dc</sub>
Input Stand-by Current		0.6		mA	V <sub>in</sub> = 5.0 V <sub>dc</sub> , module disabled
Inrush Transient			0.04	A <sup>2</sup> s	
Input Reflected Ripple Current		35		mAp-p	
Input Ripple Rejection		30		dB	120 Hz

Caution: The power modules are not internally fused. An external input line fast-blow fuse with a maximum rating of 6 A is required. See the Safety Considerations section of this data sheet.

### Applications

- Intermediate Bus architecture
- Distributed power applications
- Workstations and servers
- Telecom equipment
- Enterprise networks including LANs/WANs
- Latest generation ICs (DSP, FPGA, ASIC) and microprocessor powered applications

\*RoHS Directive 2002/95/EC Jan 27 2003 including Annex.  
Specifications are subject to change without notice.  
Customers should verify device performance in their specific applications.

# MX5A-3-5SA SMT Non-Isolated Power Module

**BOURNS®**

## Electrical Specifications (Continued)

Characteristic	Min.	Nom.	Max.	Units	Notes & Conditions
Output Voltage Setpoint Accuracy	-2.0		2.0	% $V_{O,set}$	$V_{in}$ min, $I_O$ max, $T_A = 25\text{ }^\circ\text{C}$
Output Voltage Tolerance	-3.0		3.0	% $V_{O,set}$	Over all rated in out voltage, load and temperature conditions
Voltage Adjustment Range	0.7525		3.63	$V_{dc}$	
Line Regulation		0.1		% $V_{O,set}$	
Load Regulation		0.3		% $V_{O,set}$	
Temperature Regulation		0.4		% $V_{O,set}$	
Output Current	0.0		5.0	$A_{dc}$	
Output Current Limit Inception (Hiccup Mode)			220	% $I_O$ max	
Output Short Circuit Current		2		$A_{dc}$	$V_O \leq 250\text{ mV}$ – Hiccup Mode
Output Ripple and Noise Voltage RMS Peak-to-Peak		10 40	15 50	mVrms mVpk-pk	1 $\mu\text{F}$ ceramic/10 $\mu\text{F}$ tantalum capacitors 5 Hz to 20 MHz bandwidth
External Capacitance - ESR $\geq 1\text{ m}\Omega$ - ESR $\geq 10\text{ m}\Omega$			1000 3000	$\mu\text{F}$ $\mu\text{F}$	
Efficiency ( $V_{in} = 5\text{ }V_{dc}$ , $T_A = 25\text{ }^\circ\text{C}$ , Full Load)		79.0 85.0 87.0 88.5 92.0 94.0		% % % % % %	$V_{O,set} = 0.75\text{ }V_{dc}$ $V_{O,set} = 1.2\text{ }V_{dc}$ $V_{O,set} = 1.5\text{ }V_{dc}$ $V_{O,set} = 1.8\text{ }V_{dc}$ $V_{O,set} = 2.5\text{ }V_{dc}$ $V_{O,set} = 3.3\text{ }V_{dc}$
Switching Frequency		300		kHz	
Dynamic Load Response 2.5 A to 5 A; 5 A to 2.5 A; ( $\Delta i/\Delta t = 2.5\text{ A}/\mu\text{s}$ ; $25\text{ }^\circ\text{C}$ )		130 25		mV $\mu\text{s}$	1 $\mu\text{F}$ ceramic/10 $\mu\text{F}$ tantalum capacitor Peak Deviation Settling Time ( $V_O < 10\%$ peak deviation)
2.5 A to 5 A; 5 A to 2.5 A; ( $\Delta i/\Delta t = 2.5\text{ A}/\mu\text{s}$ ; $25\text{ }^\circ\text{C}$ )		50 50		mV $\mu\text{s}$	2 x 150 $\mu\text{F}$ polymer capacitors Peak Deviation Settling Time ( $V_O < 10\%$ peak deviation)

## General Specifications

Characteristic	Nom.	Units	Notes & Conditions
Calculated MTBF	19,000,000	hours	
Weight	2.2 (0.08)	g (oz.)	

# MX5A-3-5SA SMT Non-Isolated Power Module

**BOURNS®**

## Feature Specifications

Characteristic	Min.	Nom.	Max.	Units	Notes & Conditions
Remote Enable Open = On (Logic Low) Low = Off (Logic High)	>2.5		0.4 5.5	$V_{dc}$ $V_{dc}$	10 $\mu$ A max. 1 mA max.
Turn-On Delay and Rise Times Case 1: On/Off Low – $V_{in}$ Applied Case 2: $V_{in}$ Applied, then On/Off Set Low Case 3: Output Voltage Rise		2.5 2.5 3.0		msec msec msec	(10 %-90 % of $V_O$ setting)
Output Voltage Overshoot			1	% $V_{O, set}$	$I_O$ max, $V_{in}=5.5$ , $T_A=25$ °C
Overtemperature Protection		135		°C	See Thermal Consideration section
Input Undervoltage Lockout -Turn-on Threshold -Turn-off Threshold		2.2 2.0		V V	

## Characteristic Curves

The curves provided below are typical characteristics for the MX5A-3-5SA modules at 25 °C. For any specific test configurations or any specific test requests, please contact Bourns.

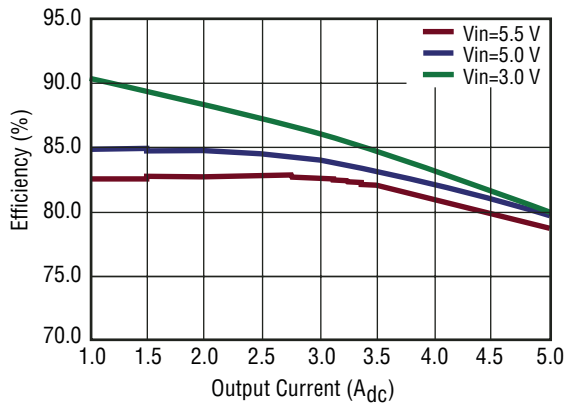


Fig. 1 Efficiency vs. Output Current ( $V_{out} = 0.75 V_{dc}$ )

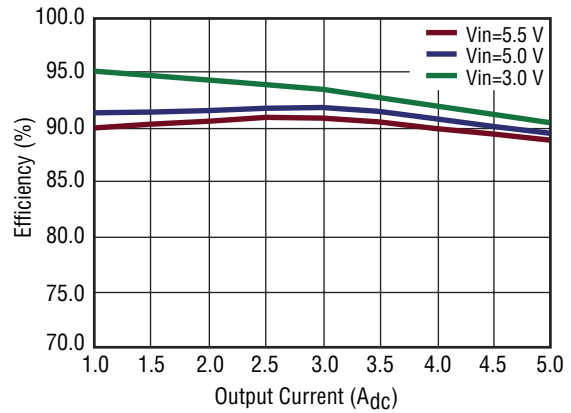


Fig. 4 Efficiency vs. Output Current ( $V_{out} = 1.8 V_{dc}$ )

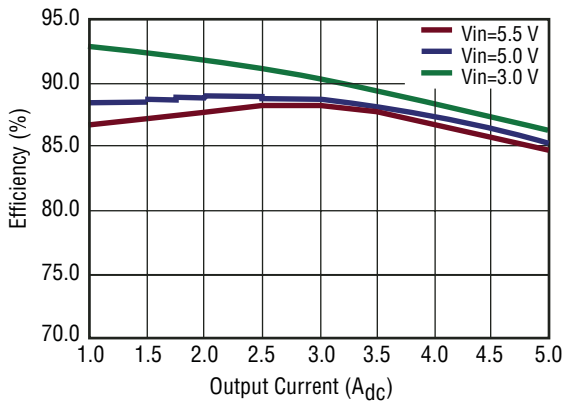


Fig. 2 Efficiency vs. Output Current ( $V_{out} = 1.2 V_{dc}$ )

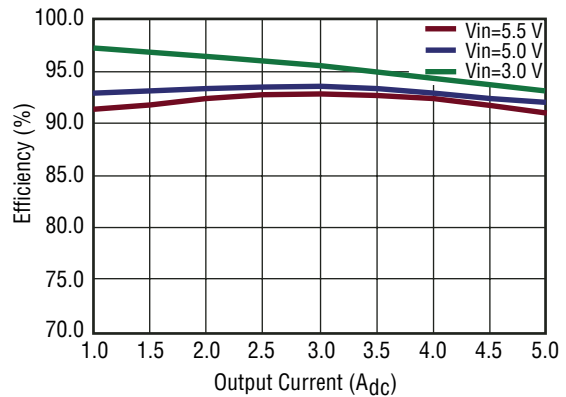


Fig. 5 Efficiency vs. Output Current ( $V_{out} = 2.5 V_{dc}$ )

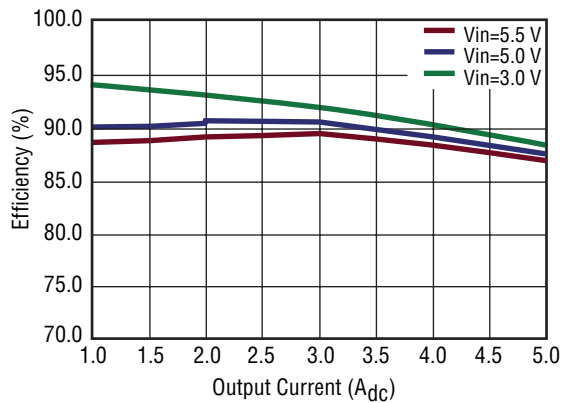


Fig. 3 Efficiency vs. Output Current ( $V_{out} = 1.5 V_{dc}$ )

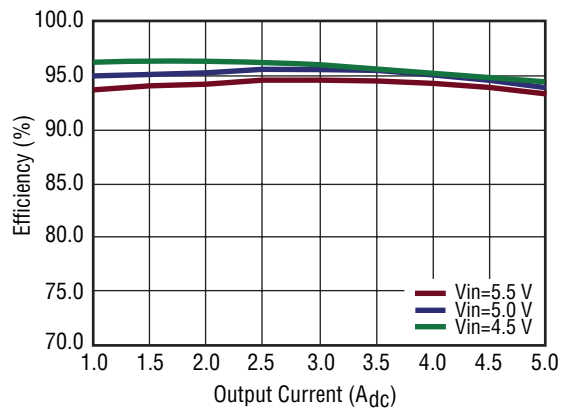
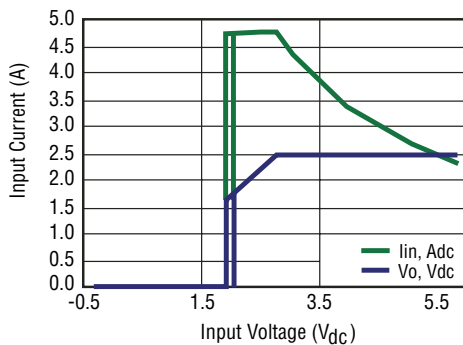
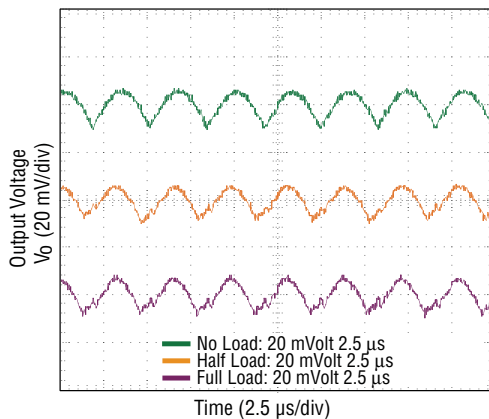


Fig. 6 Efficiency vs. Output Current ( $V_{out} = 3.3 V_{dc}$ )

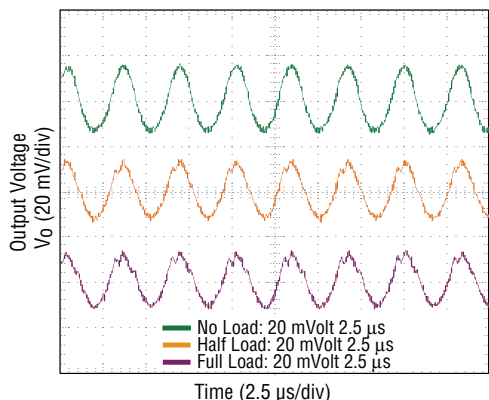
## Characteristic Curves (Continued)



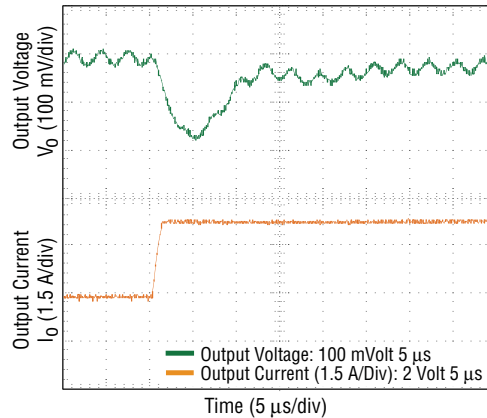
**Fig. 7 Input Voltage vs.  $I_O$  and  $V_O$**   
( $V_O = 2.5 V_{DC}$ ,  $I_O = 5.0 A$ )



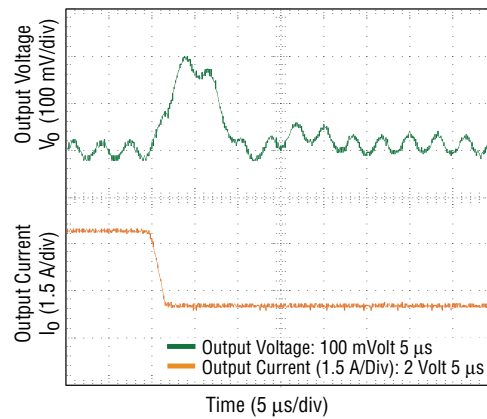
**Fig. 8 Typical Output Ripple and Noise**  
( $V_{IN} = 5.0 V$ ,  $V_O = 0.75 V$ ,  $I_O = 5.0 A$ )



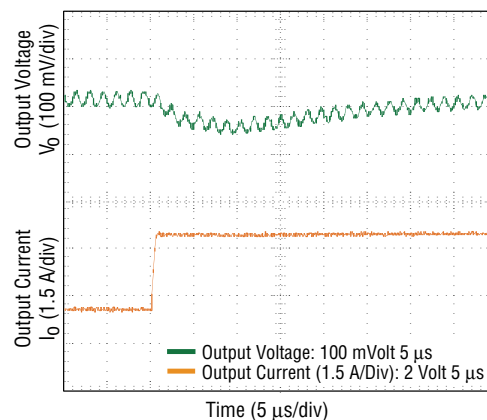
**Fig. 9 Typical Output Ripple and Noise**  
( $V_{IN} = 5.0 V$ ,  $V_O = 3.3 V$ ,  $I_O = 5.0 A$ )



**Fig. 10 Transient Response - 2.5 A - 5 A Step**  
( $V_O = 3.3 V_{DC}$ )

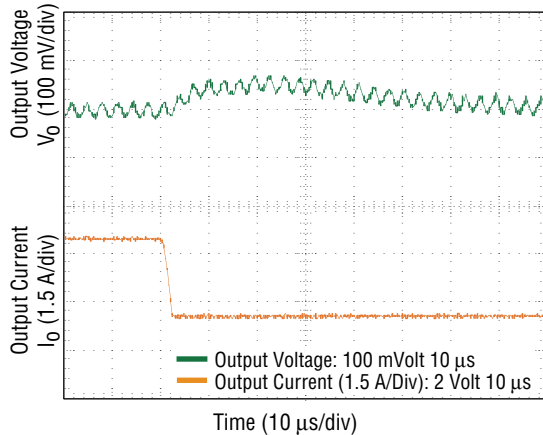


**Fig. 11 Transient Response - 5 A - 2.5 A Step**  
( $V_O = 3.3 V_{DC}$ )

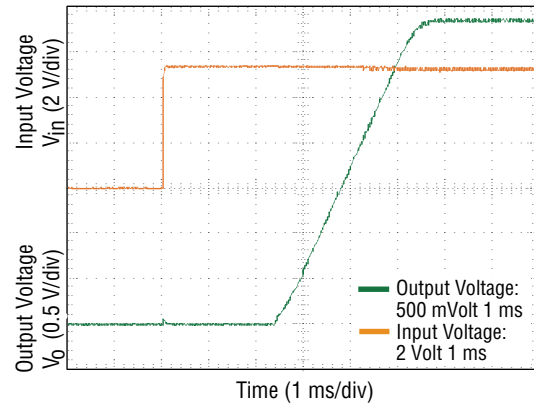


**Fig. 12 Transient Response - 2.5 A - 5 A Step**  
( $V_O = 3.3 V_{DC}$ ,  $C_{ext} = 2 \times 100 \mu F$  Polymer Capacitors)

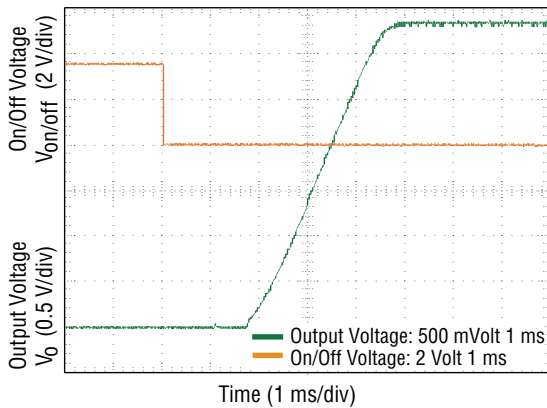
## Characteristic Curves (Continued)



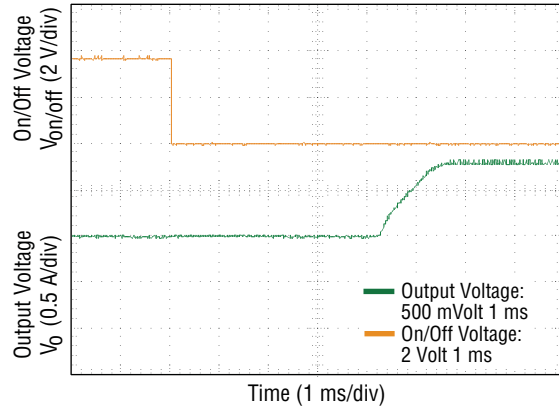
**Fig. 13 Transient Response - 5 A - 2.5 A Step**  
( $V_O = 3.3 V_{DC}$ ,  $C_{ext} = 2 \times 100 \mu F$  Polymer Capacitors)



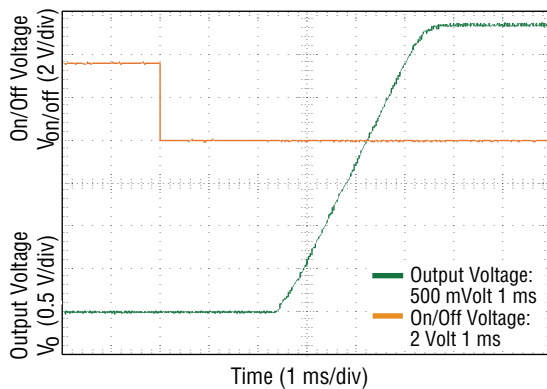
**Fig. 16 Typical Start-up with Application of  $V_{in}$**   
( $V_{in} = 5 V_{DC}$ ,  $V_O = 3.3 V_{DC}$ ,  $I_O = 5 A$ )



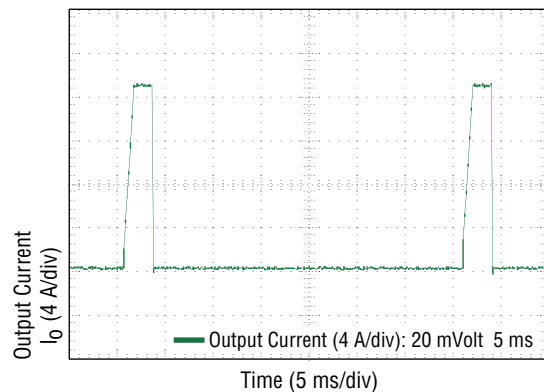
**Fig. 14 Typical Start-up using Remote On/Off**  
( $V_{in} = 5 V_{DC}$ ,  $V_O = 3.3 V_{DC}$ ,  $I_O = 5 A$ )



**Fig. 17 Typical Start-up using Remote On/Off with Prebias**  
( $V_{in} = 5 V_{DC}$ ,  $V_O = 1.8 V_{DC}$ ,  $I_O = 1 A$ ,  $V_{bias} = 1 V_{DC}$ )



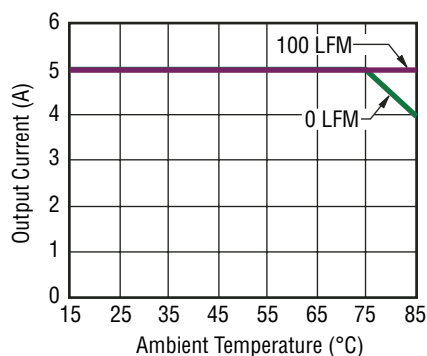
**Fig. 15 Typical Start-up using Remote On/Off with Low-ESR External Capacitors (10x100  $\mu F$  Polymer)**  
( $V_{in} = 5.0 V_{DC}$ ,  $V_O = 3.3 V_{DC}$ ,  $I_O = 5.0 A$ ,  $C_O = 1000 \mu F$ )



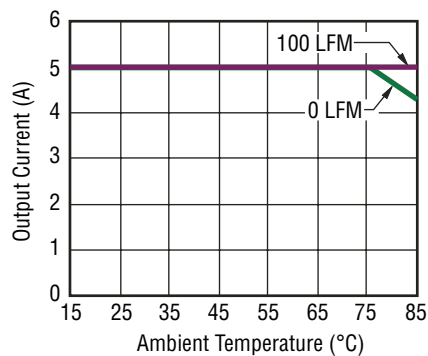
**Fig. 18 Output Short Circuit Current**  
( $V_{in} = 5.0 V_{DC}$ ,  $V_O = 0.75 V_{DC}$ )

Specifications are subject to change without notice.  
Customers should verify device performance in their specific applications.

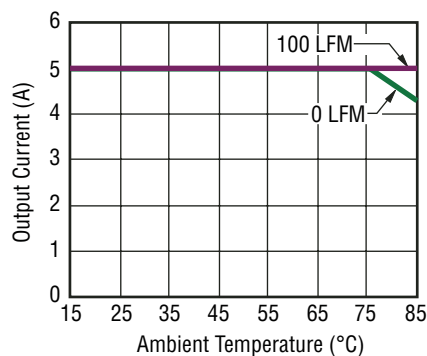
## Characteristic Curves (Continued)



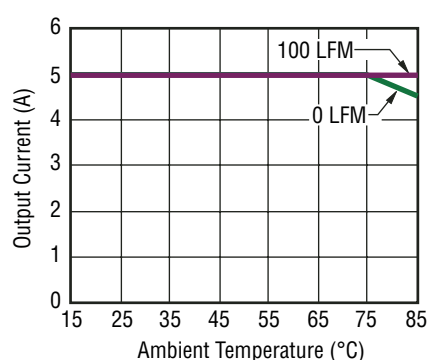
**Fig. 19 Derating Output Current vs. Local Ambient Temp. and Airflow**  
 $(V_{in} = 5.0 V_{dc}, V_o = 3.3 V_{dc})$



**Fig. 21 Derating Output Current vs. Local Ambient Temp. and Airflow**  
 $(V_{in} = 5.0 V_{dc}, V_o = 2.5 V_{dc})$



**Fig. 20 Derating Output Current vs. Local Ambient Temp. and Airflow**  
 $(V_{in} = 5.0 V_{dc}, V_o = 0.75 V_{dc})$



**Fig. 22 Derating Output Current vs. Local Ambient Temp. and Airflow**  
 $(V_{in} = 3.3 V_{dc}, V_o = 0.75 V_{dc})$

## Operating Information

### Remote On/Off

The MX5A-3-5SA comes standard with Active LOW with Negative On/Off logic, i.e., OPEN or LOW ( $< 0.4$  V) will turn ON the device. To turn the device OFF, increase the voltage level above 2.4 V, placing the part into low dissipation sleep mode. The signal level of the On/Off pin input is defined with respect to ground.

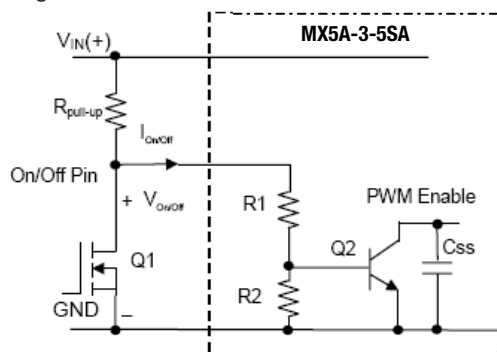


Fig. 23 Circuit Configuration for using Negative Logic On/Off

### Input Considerations

The input must have a stable low impedance AC source for optimum performance. This can be accomplished with external ceramic capacitors, tantalum capacitors and/or polymer capacitors. Using low impedance tantalum capacitors requires about  $20 \mu\text{F}$  per Amp and an ESR of  $250 \text{ m}\Omega$  per Amp of output current. For a 5 A converter, tantalum capacitors with a combined value of  $100 \mu\text{F}$  and  $50 \text{ m}\Omega$  would be adequate. This can be implemented with (2)  $47 \mu\text{F}$  tantalum capacitors with an ESR of  $100 \text{ m}\Omega$ . Ceramic capacitors are also recommended to reduce high frequency ripple on the input.

### Output Considerations

To maintain the specified output ripple and transient response, external capacitors must be used. An external  $1 \mu\text{F}$  ceramic capacitor in parallel with a  $10 \mu\text{F}$  low ESR tantalum capacitor will usually meet the specified performance. Improved performance can be achieved by using more capacitance. Low ESR polymer capacitors may also be used. Two  $100 \mu\text{F}$ ,  $9 \text{ m}\Omega$  or lower ESR capacitors are recommended.

### Safety Information

In order to comply with safety requirements the user must provide a fuse in the unearthed input line. This is to prevent earth being disconnected in the event of a failure.

The converter must be installed as per guidelines outlined by the various safety approvals if safety agency approval is required for the overall system.

### Overtemperature Protection

The device will shut down if it becomes too hot (typically  $135 \text{ }^\circ\text{C}$  – at controller IC). Once the converter cools, it automatically restarts. This feature does not guarantee the converter won't be damaged by temperatures above its rating.

### Overcurrent Protection

The device has an internally set output current limit to protect it from overloads, placing the unit in hiccup mode. Once the overload is removed the converter automatically resumes normal operation. No user adjustments are available. An external fuse in series with the input voltage is also required for complete overload protection.

### Input Undervoltage Lockout

The device operation is disabled if the input voltage drops below the specified input range. Once the input returns to the specified range operation automatically resumes. No user adjustments are available.



## Operating Information (Continued)

### Output Voltage Setting

The output voltage can be programmed to any voltage between 0.75 Vdc and 3.3 Vdc by connecting a single resistor between the trim pin and the GND pin of the module, as shown in Fig. 24 below.

If left open circuit the output voltage will default to 0.75 Vdc. The correct Rtrim value for a specific voltage can be calculated using the following equation:

$$R_{trim} = [21.07 / (V_o - 0.7525) - 5.11] \text{ k}\Omega$$

For example, to set the MX5A-3-5SA to 3.3 V the following Rtrim resistor must be used:

$$R_{trim} = [21.07 / (3.3 - 0.7525) - 5.11] \text{ k}\Omega$$

Rtrim = 3.161 kΩ,  
The closest standard 1 % E96 value is 3.16 kΩ.

Table 1 provides the Rtrim values required for some common output voltage set points.

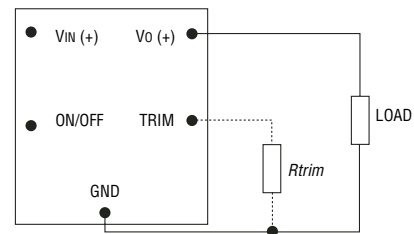


Fig. 24 Circuit Configuration to Program Output Voltage using an External Resistor

MX5A-3-5SA Rtrim Values		
Vo (V)	Rtrim (kΩ)	1 % Value
0.75	Open	Open
1.0	80.02	80.6
1.2	41.97	42.2
1.5	23.08	23.2
1.8	15.00	15.0
2.0	11.78	11.8
2.5	6.947	6.98
3.3	3.161	3.16

Table 1

The output voltage of the device can also be set by applying a voltage between the TRIM and GND pins. The Vtrim equation can be written as follows:

$$V_{trim} = (0.7 - 0.1698 \times (V_o - 0.7225))$$

To set Vo = 3.3 V, the Vtrim required would therefore be 0.2670 V.

Table 2 below provides the Vtrim values required for some common output voltage set points.

MX5A-3-5SA Vtrim Values	
Vo (V)	Vtrim (V)
0.75	Open
1.0	0.6580
1.2	0.6240
1.5	0.5731
1.8	0.5221
2.0	0.4882
2.5	0.4033
3.3	0.2674

Table 2

## Operating Information (Continued)

### Voltage Margining

Output voltage margining can be implemented as follows:

- 1) Trim-up: Connect a resistor,  $R_{m-up}$ , from the Trim pin to the ground pin for adjusting the voltage upwards, and
- 2) Trim-down: Connect a resistor,  $R_{m-down}$ , from the Trim pin to the output pin for adjusting the voltage downwards.

Please consult your local Bourns Field Applications Engineer for more details and the calculation of the required resistor values.

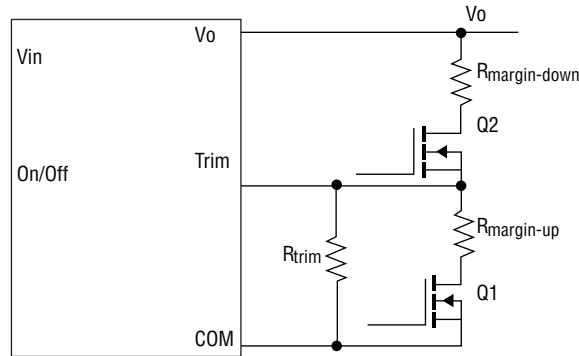


Fig. 25 Circuit Configuration for Margining Output Voltage

### Thermal Considerations

Sufficient cooling must always be considered to ensure reliable operation, as these devices operate in a variety of thermal environments.

Factors such as ambient temperature, airflow, power dissipation and reliability must be taken into consideration.

The data presented in Figures 19 to 22 is based on physical test results taken in a wind tunnel test. The test set-up is shown in Figure 27.

The thermal reference points are (1)  $T_{ref1}$  = temp at dual Mosfet, as shown in Figure 26, and (2)  $T_{ref2}$  = temp at controller IC. For reliable operation, neither  $T_{ref1}$  or  $T_{ref2}$  should exceed 115 °C.

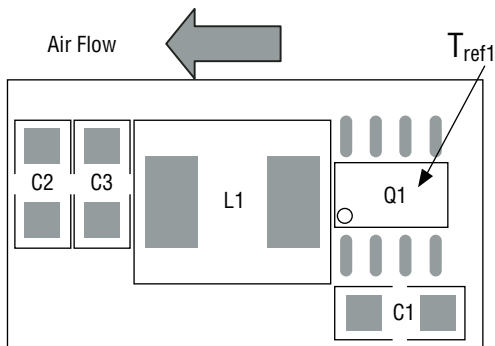


Fig. 26  $T_{ref1}$  Temperature Measurement Location

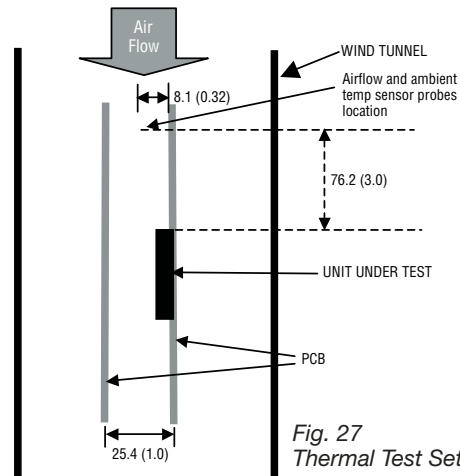


Fig. 27 Thermal Test Set-up

# MX5A-3-5SA SMT Non-Isolated Power Module

**BOURNS®**

## Product Dimensions

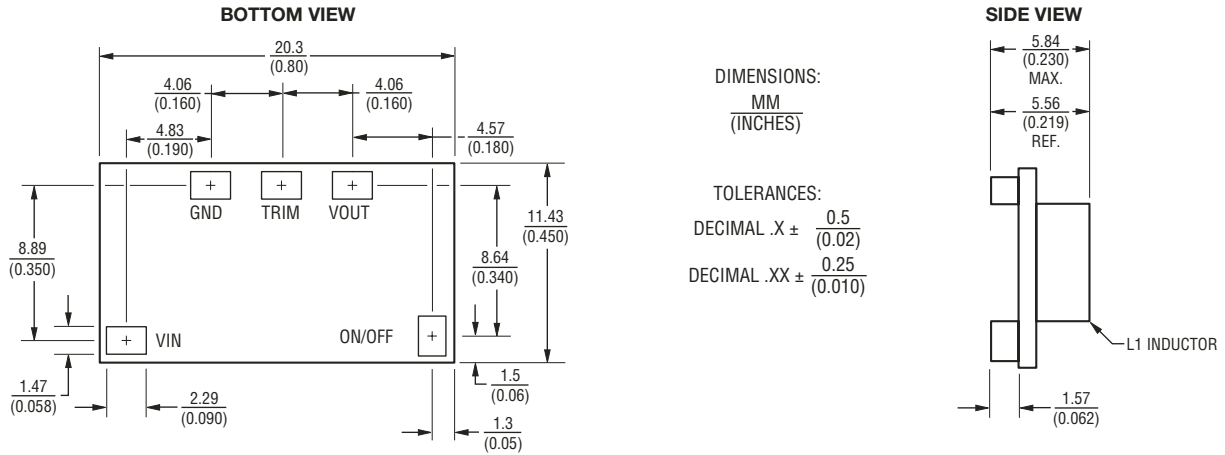


Fig. 28 Product Dimensions

## Coplanarity

The MX5A-3-5SA device has a maximum coplanarity of 100 μm (approx. 0.004 ″), as defined by JESD22-B108.

## Pin Plating Composition

Tin (Sn) plating over nickel (Ni).

## Recommended Pad Layout

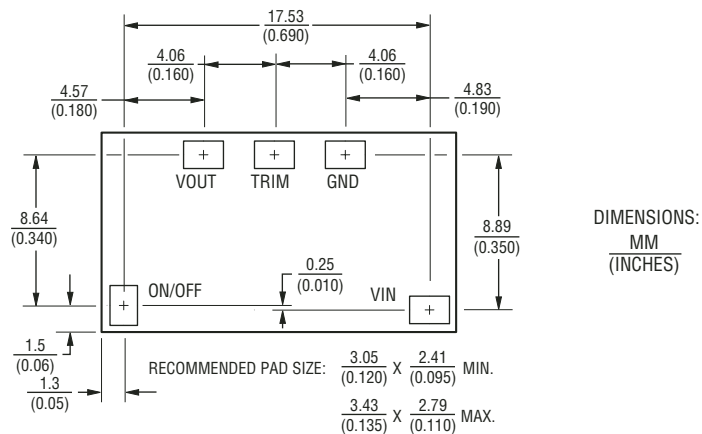


Fig. 29 Recommended Pad Layout

# MX5A-3-5SA SMT Non-Isolated Power Module

**BOURNS®**

## Use in Manufacturing Environment

### Pick and Place Information

Bourns SMT devices, packaged on tape and reel, are designed (low mass) for automated assembly using standard SMT pick and place equipment. The centrally located inductor provides the flat surface area to be used for component pick up. Variables such as nozzle style, nozzle size, handling speed, and placement pressure need to be optimized for best results.

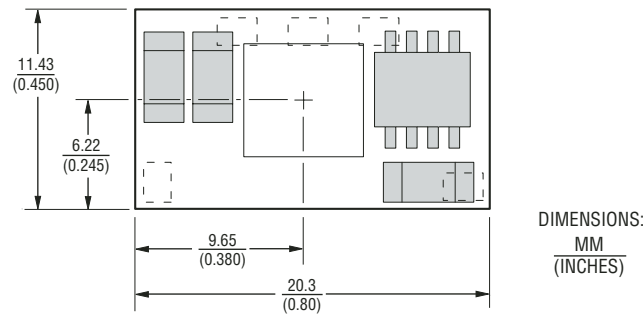


Fig. 30 Pick and Place Location

### Packaging Information

Devices come in 44 mm tape and reel, as per EIA-481-2.

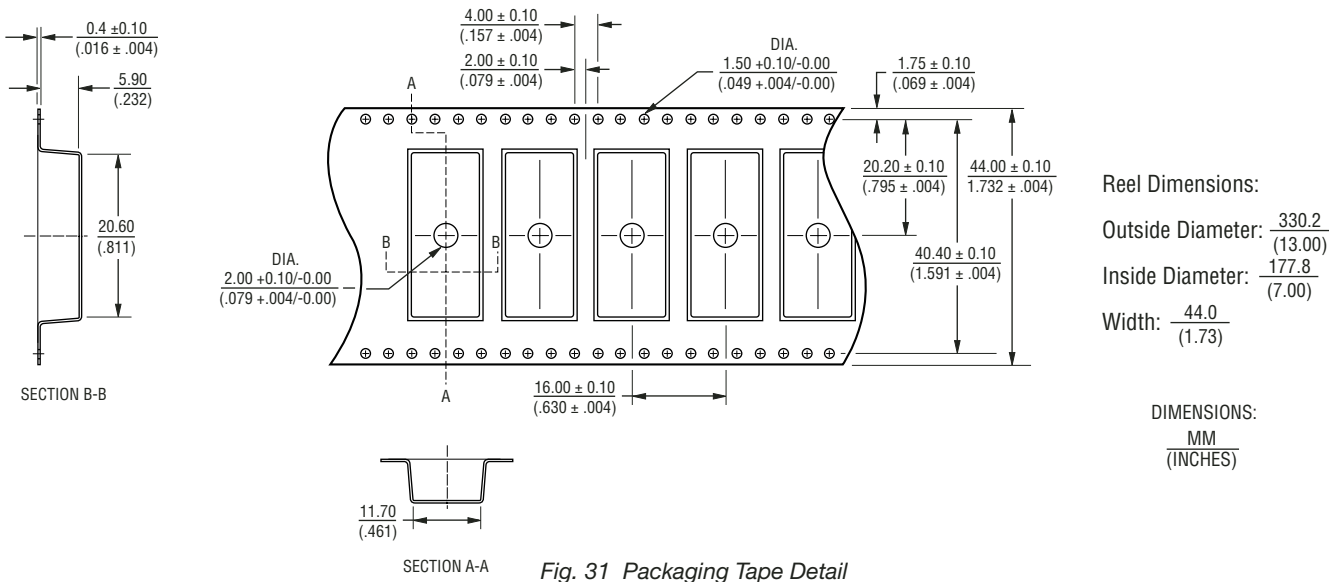


Fig. 31 Packaging Tape Detail

### PCB Layout for SMT Devices

- Use a solder mask defined pad design.
- See specific datasheet for recommended minimum and maximum pad size.
- Interconnection to internal power planes is typically required.
- “Via-in-pad” design should be avoided in the SMT pads.
- Solder mask should be used to eliminate solder wicking into the vias.
- Low resistance and low inductance PCB layout traces should be used where possible, particularly on the output side.
- A low impedance track between the input ground and output ground is very important to achieve high efficiencies.

## Use in Manufacturing Environment (Continued)

### Soldering Requirements

Bourns recommends the following temperature profile for use on tin lead solder (Sn-Pb Eutectic) and lead free solder. For lead free solder, the maximum temperature during the mounting process should not exceed 245 °C. Sufficient time must be allowed to fuse the plating on the connection to ensure a reliable solder joint. However, the time above 230 °C should not exceed 60 seconds.

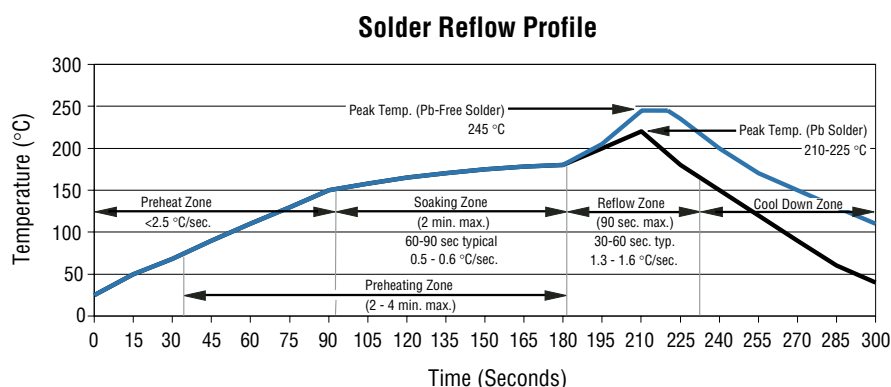


Fig. 32 Suggested Reflow Profile

### Water Washing

A non-clean solder paste system should be used for solder attach onto application boards. The parts are suitable for water washing applications. However, the user must ensure that the drying process is sufficient to remove all water from the module after washing and that the module is never powered up prior to the module being fully dried.

### Inspection/Rework

Conventional techniques may be employed when replacing a unit in the application. Using a precision dispenser or a suitable mini-stencil, a suitable volume of solder paste should be applied to the cleaned pads. Reflow can be achieved by standard SMT rework techniques such as IR or techniques developed for BGA components.

### ESD Requirements

Bourns manufactures all models in an ESD controlled environment and all product is supplied in conductive packaging to prevent ESD damage from occurring before or during shipping. All products must be unpacked and handled using approved ESD control procedures. Failure to do so may affect the lifetime of the converter.

### Storage

The X & XT Series have an MSL rating of 1 per IPC/JEDEC J-STD-033A.



*Reliable Electronic Solutions*

**Asia-Pacific:** Tel: +886-2 2562-4117 • Fax: +886-2 2562-4116  
**Europe:** Tel: +41-41 768 5555 • Fax: +41-41 768 5510  
**The Americas:** Tel: +1-951 781-5500 • Fax: +1-951 781-5700  
[www.bourns.com](http://www.bourns.com)