

LOC	DIST	REVISIONS					
E	B	P	LTR	DESCRIPTION	DATE	DWN	APVD
		BA		NEW RELEASE	01-DEC-08	SM	St.P

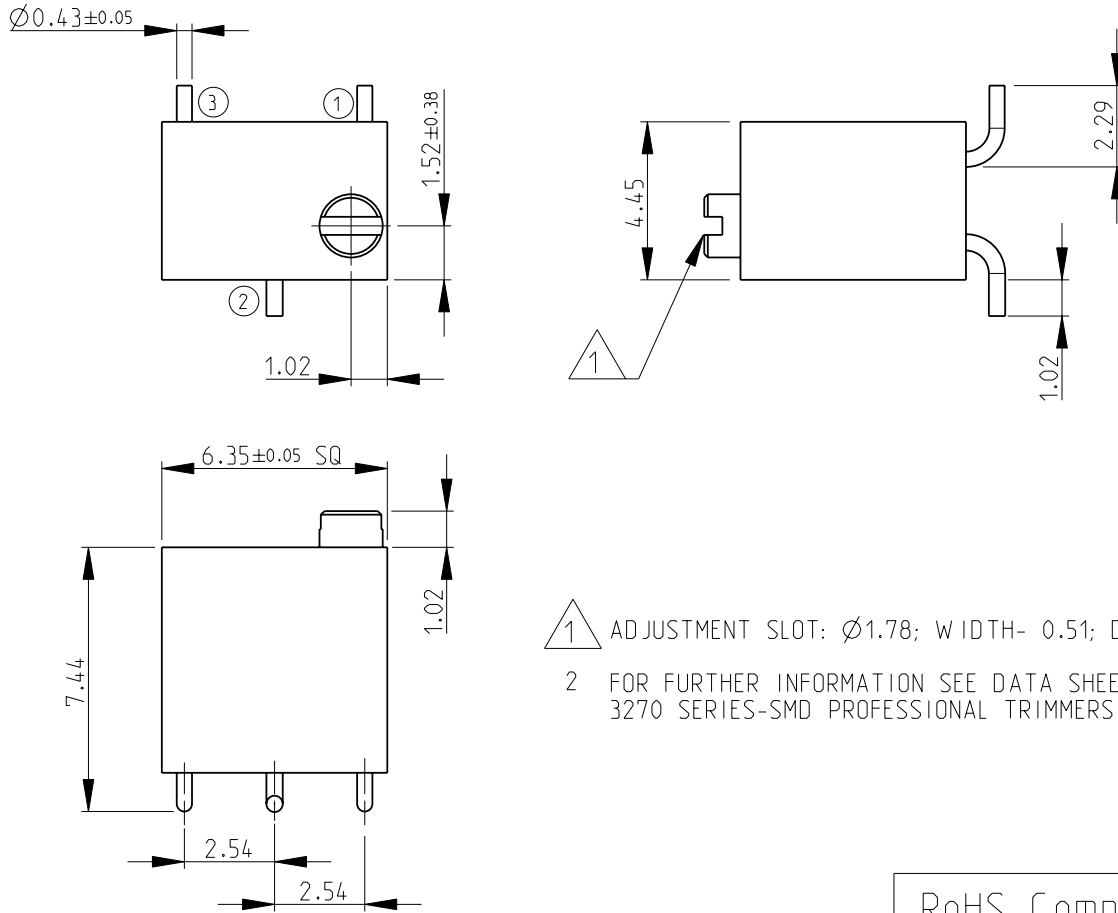

- 1 ADJUSTMENT SLOT: Ø1.78; WIDTH- 0.51; DEPTH- 0.51
- 2 FOR FURTHER INFORMATION SEE DATA SHEET FOR 3270 SERIES-SMD PROFESSIONAL TRIMMERS

RoHS Compliant

RECOMMENDED LAND PATTERN

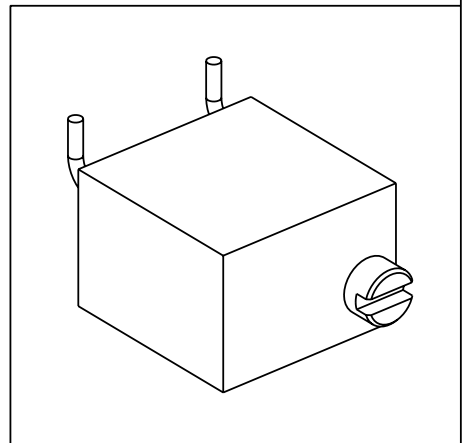
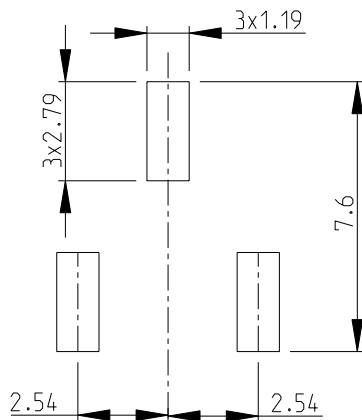

2008

RELEASED FOR PUBLICATION

THIS DRAWING IS UNPUBLISHED.

© COPYRIGHT 2008 BY TYCO ELECTRONICS CORPORATION. ALL RIGHTS RESERVED.

DIMENSIONS: mm	DWN	SUBHASH.M	01-DEC-08	MATERIAL	-	FINISH	-
	CHK	PRAKASH.S	01-DEC-08	Tyco Electronics Corporation Dorcan, Swindon, SN3 5HH			
TOLERANCES UNLESS OTHERWISE SPECIFIED:	APVD	STEPHEN.P	01-DEC-08				
0 PLC ±0.2	PRODUCT SPEC	-	-	NAME			
1 PLC ±0.1	APPLICATION SPEC	-	-	SMD PROFESSIONAL TRIMMERS			
2 PLC ±-	WEIGHT	-	-	SERIES 3270W			
3 PLC ±-				SIZE	CAGE CODE	DRAWING NO	RESTRICTED TO
4 PLC ±-				A 4	00779	©= 1623912	-
ANGLES ±5°				CUSTOMER DRAWING			
				SCALE	5:1	SHEET 1 OF 1	REV BA