

LOC	DIST	REVISIONS				
P	LTR	DESCRIPTION	DATE	DWN	APVD	
E	B	BA	NEW RELEASE	13-NOV-08	SM	St.P

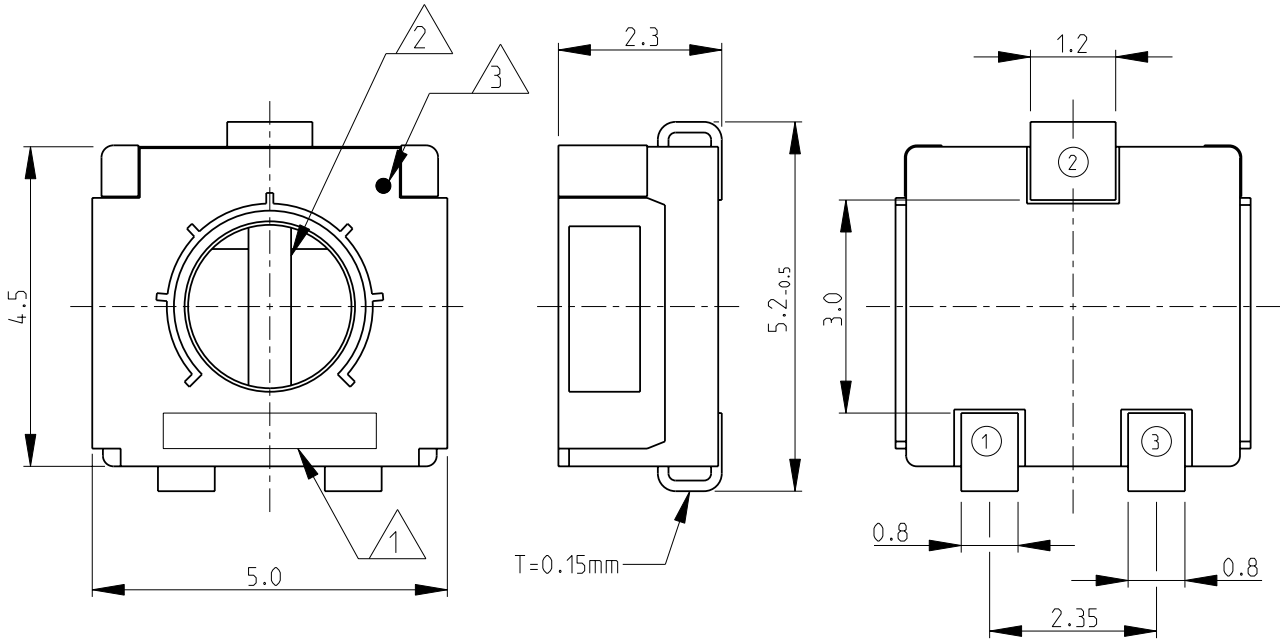

RoHS Compliant

- 1 RESISTANCE / DATE CODE
- 2 ADJUSTMENT SLOT:  
WIDTH- 0.6mm, LENGTH- 2.3mm, DEPTH- 0.5mm
- 3 LEAD-FREE IDENTIFICATION MARK
- 4 FOR FURTHER INFORMATION SEE DATA SHEET FOR  
3315 SERIES-SMD PROFESSIONAL TRIMMERS

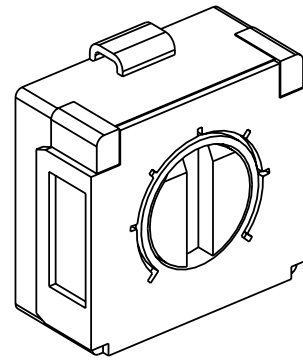

SCALE 8:1

2008

RELEASED FOR PUBLICATION

THIS DRAWING IS UNPUBLISHED.

© COPYRIGHT 2008 BY TYCO ELECTRONICS CORPORATION. ALL RIGHTS RESERVED.

DIMENSIONS: mm		DWN SUBHASH.M	13-NOV-08	MATERIAL	-	FINISH	-
TOLERANCES UNLESS OTHERWISE SPECIFIED:		CHK PRAKASH.S	13-NOV-08	Tyco Electronics Corporation Dorcan, Swindon, SN3 5HH			
		APVD STEPHEN.P	13-NOV-08				
0 PLC ±0.2		PRODUCT SPEC		NAME SMD PROFESSIONAL TRIMMERS SERIES 3315			
1 PLC ±0.1		APPLICATION SPEC		SIZE	CAGE CODE	DRAWING NO	RESTRICTED TO
2 PLC ±-		-		A 4	00779	© = 1623905	-
3 PLC ±-		-		SCALE 10:1 SHEET 1 OF 1 REV BA			
4 PLC ±-		-					
ANGLES ±5°		WEIGHT 0.12g					
CUSTOMER DRAWING							

AMP 1469-35 REV 31MAR2000