

NON-ISOLATED DC/DC CONVERTERS

4.5 Vdc - 13.2 Vdc Input 0.9 Vdc - 5.0 Vdc/3 A Output

bel
POWER PRODUCTS

xRAH-03Exx0 Series RoHS Compliant Rev.A

- Non-Isolated
- Trim Function
- Low Profile Package (7.82 mm)
- UL60950-1 Recognized (UL/cUL)
- Remote On/Off
- OCP/SCP
- Under-Voltage Lockout (UVLO)

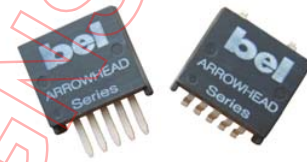

Description

The Bel xRAH-03Exx0 is part of the low cost non-isolated dc/dc converter Power Module series. The modules use a SMD or SIP package for ease of layout and space savings. The output is closely regulated and the efficiency of 3.3 Vdc output module is typically 93% at full load.

Part Selection

Output Voltage	Input Voltage	Max. Output Current	Max. Output Power	Typical Efficiency	Part Number Surface Mount	Part Number Vertical Mount
5.0 Vdc	8.0 Vdc - 13.2 Vdc	3 A	15 W	95%	SRAH-03E500	VRAH-03E500
3.3 Vdc	4.5 Vdc - 13.2 Vdc	3 A	9.9 W	93%	SRAH-03E330	VRAH-03E330
2.5 Vdc	4.5 Vdc - 13.2 Vdc	3 A	7.5 W	91%	SRAH-03E250	VRAH-03E250
1.8 Vdc	4.5 Vdc - 13.2 Vdc	3 A	5.4 W	88%	SRAH-03E180	VRAH-03E180
1.5 Vdc	4.5 Vdc - 13.2 Vdc	3 A	4.5 W	87%	SRAH-03E150	VRAH-03E150
1.2 Vdc	4.5 Vdc - 13.2 Vdc	3 A	3.6 W	85%	SRAH-03E120	VRAH-03E120
1.0 Vdc	4.5 Vdc - 13.2 Vdc	3 A	3 W	84%	SRAH-03E100	VRAH-03E100
0.9 Vdc	4.5 Vdc - 13.2 Vdc	3 A	2.7 W	82%	SRAH-03E090	VRAH-03E090

- Notes:** 1. Add "0" suffix at the end of the model number to indicate "Tube Packaging", and "R" for "Reel Packaging", and "G" for "Tray Packaging".
2. All part numbers above indicate RoHS 6. Change the second letter "R" to "7" for RoHS 5 part numbers.

Absolute Maximum Ratings

Parameter	Min	Typ	Max	Notes
Input Voltage (continuous)	-0.3 V	-	14 V	
Output Enable Terminal Voltage	-0.3 V	-	13.2 V	
Ambient Temperature	0 °C	-	70 °C	
Storage Temperature	-40 °C	-	100 °C	

Input Specifications

Parameter	Min	Typ	Max	Notes
Input Voltage	4.5 V	-	13.2 V	Min. input voltage for 5.0 V output module should be 8.0 V
Input Current (no load)	-	30 mA	-	
Input Current (full load)	-	-	3 A	
Remote Off Input Current	-	4 mA	-	
Input Reflected Ripple Current (pk-pk)	-	75 mA	150 mA	With simulated source impedance of 500 nH, 5 Hz to 20 MHz; Use two 270 uF/16 V Oscon capacitors with ESR = 0.018 ohm max. at 100 kHz at 25 °C
Input Reflected Ripple Current (rms)	-	30 mA	60 mA	
I ² t Inrush Current Transient	-	0.02 A ² s	0.08 A ² s	
Turn-on Voltage Threshold	-	4.1 V	4.5 V	Not applicable for 5.0 V output.
Turn-off Voltage Threshold	-	3.3 V	4.0 V	

NON-ISOLATED DC/DC CONVERTERS

4.5 Vdc - 13.2 Vdc Input 0.9 Vdc - 5.0 Vdc/3 A Output



Output Specifications

Parameter	Min	Typ	Max	Notes	
Output Voltage Set Point	Vo=5.0 V	4.900 V	5.0 V	5.100 V	Test condition: Vin=8 V, Iout=full load
	Vo=3.3 V	3.234 V	3.3 V	3.366 V	
	Vo=2.5 V	2.450 V	2.5 V	2.550 V	
	Vo=1.8 V	1.764 V	1.8 V	1.836 V	
	Vo=1.5 V	1.470 V	1.5 V	1.530 V	
	Vo=1.2 V	1.176 V	1.2 V	1.224 V	
	Vo=1.0 V	0.980 V	1.0 V	1.020 V	
Line Regulation	Vo=5.0 V	-	10 mV	15 mV	
	Vo=3.3 V	-	8 mV	10 mV	
	Vo=2.5 V	-	6 mV	10 mV	
	Vo=1.8 V	-	6 mV	10 mV	
	Vo=1.5 V	-	5 mV	8 mV	
	Vo=1.2 V	-	5 mV	8 mV	
	Vo=1.0 V	-	5 mV	8 mV	
Load Regulation	Vo=5.0 V	-	15 mV	25 mV	
	Vo=3.3 V	-	10 mV	20 mV	
	Vo=2.5 V	-	8 mV	15 mV	
	Vo=1.8 V	-	8 mV	15 mV	
	Vo=1.5 V	-	5 mV	10 mV	
	Vo=1.2 V	-	5 mV	10 mV	
	Vo=1.0 V	-	5 mV	10 mV	
Regulation Over Temperature (0 °C to 70 °C)	-	20 mV	40 mV		
Output Current	0 A	-	3 A		
Current Limit Threshold	3.3 A	-	8 A		
Short Circuit Surge Transient	-	0.02 A ² s	0.08 A ² s		
Ripple and Noise (rms)	-	15 mV	40 mV	BW = 0-20 MHz.	
Ripple and Noise (pk-pk)	-	50 mV	100 mV	BW = 0-20 MHz.	
Turn on Time	-	-	60mS		
Overshoot at Turn on	-	0%	3%		
Output Capacitance	0 uF	-	1200 uF		
Transient Response					
50% ~ 100% Max Load	Overshoot	Vo=5 V	-	150 mV	di/dt = 0.5 A/uS; Vin = 8 V; Ta = 25 °C and with a 220 uF Tan. capacitor on output
	Settling Time		-	60 uS	
100% ~ 50% Max Load	Overshoot	Vo=5 V	-	150 mV	
	Settling Time		-	60 uS	
50% ~ 100% Max Load	Overshoot	Vo=3.3 V	-	110 mV	
	Settling Time		-	60 uS	
100% ~ 50% Max Load	Overshoot	Vo=3.3 V	-	110 mV	
	Settling Time		-	60 uS	
50% ~ 100% Max Load	Overshoot	Vo=2.5 V	-	110 mV	
	Settling Time		-	60 uS	
100% ~ 50% Max Load	Overshoot	Vo=2.5 V	-	110 mV	
	Settling Time		-	60 uS	

NON-ISOLATED DC/DC CONVERTERS

4.5 Vdc - 13.2 Vdc Input 0.9 Vdc - 5.0 Vdc/3 A Output



Output Specifications (continued)

Parameter		Min	Typ	Max	Notes
Transient Response					
50% ~ 100% Max Load	Overshoot	Vo=1.8 V	-	110 mV	150 mV
	Settling Time		-	60 μ S	100 μ S
100% ~ 50% Max Load	Overshoot	Vo=1.8 V	-	110 mV	150 mV
	Settling Time		-	60 μ S	100 μ S
50% ~ 100% Max Load	Overshoot	Vo=1.5 V	-	110 mV	150 mV
	Settling Time		-	60 μ S	120 μ S
100% ~ 50% Max Load	Overshoot	Vo=1.5 V	-	110 mV	150 mV
	Settling Time		-	60 μ S	120 μ S
50% ~ 100% Max Load	Overshoot	Vo=1.2 V	-	110 mV	150 mV
	Settling Time		-	60 μ S	100 μ S
100% ~ 50% Max Load	Overshoot	Vo=1.2 V	-	110 mV	150 mV
	Settling Time		-	60 μ S	100 μ S
50% ~ 100% Max Load	Overshoot	Vo=1.0 V	-	110 mV	150 mV
	Settling Time		-	60 μ S	100 μ S
100% ~ 50% Max Load	Overshoot	Vo=1.0 V	-	110 mV	150 mV
	Settling Time		-	60 μ S	100 μ S
50% ~ 100% Max Load	Overshoot	Vo=0.9 V	-	110 mV	150 mV
	Settling Time		-	60 μ S	100 μ S
100% ~ 50% Max Load	Overshoot	Vo=0.9 V	-	110 mV	150 mV
	Settling Time		-	60 μ S	100 μ S

di/dt = 0.5 A/ μ S; Vin = 8 V; Ta = 25 °C and with a 220 μ F electrolytic capacitor on output

Note: All specifications are typical at 8V input, full load at 25°C unless otherwise stated.

General Specifications

Parameter		Min	Typ	Max	Notes
Efficiency	Vo=5.0 V	91%	95%	-	Measured at Vin=8 V, full load
	Vo=3.3 V	89%	93%	-	
	Vo=2.5 V	87%	91%	-	
	Vo=1.8 V	84%	88%	-	
	Vo=1.5 V	83%	87%	-	
	Vo=1.2 V	81%	85%	-	
	Vo=1.0 V	80%	84%	-	
	Vo=0.9 V	78%	82%	-	
Switching Frequency ¹		200 kHz	300 kHz	400 kHz	
Output Trim Range		90% Vo	-	110% Vo	For all outputs
Protection Features					
MTBF		8,278,709 hours		Calculated Per Bell Core SR-332 (Io = 80%load; Ta = 25 °C)	
Dimensions (surface mount)		0.78 x 0.7 x 0.32			
Inches (L x W x H)		19.812 x 17.78 x 8.128			
Dimensions (vertical)		0.7 x 0.308 x 0.65			
Inches (L x W x H)		17.78 x 7.82 x 16.51			
Weight		-	5.1 g	-	

Notes: All specifications are typical at 25 °C unless otherwise stated.

1. Min. of 0.9 V output should be 100%Vo.

NON-ISOLATED DC/DC CONVERTERS

4.5 Vdc - 13.2 Vdc Input 0.9 Vdc - 5.0 Vdc/3 A Output



Control Specifications

Parameter	Min	Typ	Max	Notes
Remote On/Off				
Signal Low (Unit On)	-0.3 V	-	1 V	Remote on/off pin open, unit on.
Signal High (Unit Off)	2.8 V	-	13.2 V	

Output Trim Equations

Equations for calculating the trim resistor (in kΩ) given the desired adjusted voltage (V_{adj}) and the nominal output voltage of the converter (V_{nom}) are shown below. The Trim Down resistor should be connected between the Trim pin and Vout. The Trim Up resistor should be connected between the Trim pin and Ground. Only one of the resistors should be used for any given application.

$$R_{TrimDown} = \frac{A}{V_{nom} - V_{adj}} - B$$

$$R_{TrimUp} = \frac{C}{V_{adj} - V_{nom}} - D$$

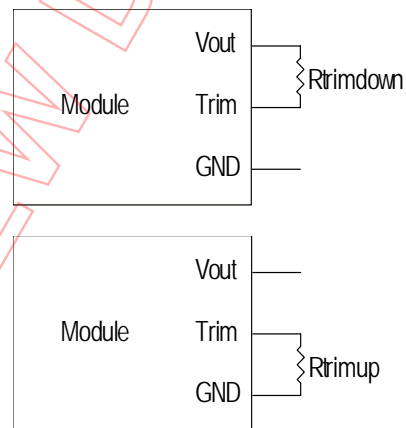

Vnom	A	B	C	D
5.0	61.940	29.400	11.760	14.700
3.3	53.840	61.700	17.200	40.200
2.5	9.596	15.620	4.496	10.000
1.8	3.850	13.830	3.064	10.000
1.5	3.120	14.420	3.536	10.000
1.2	1.790	10.910	3.536	6.490
1.0	0.511	3.490	1.992	1.000
0.9	X	X	0.960	0.100

NON-ISOLATED DC/DC CONVERTERS

4.5 Vdc - 13.2 Vdc Input 0.9 Vdc - 5.0 Vdc/3 A Output



Efficiency Data

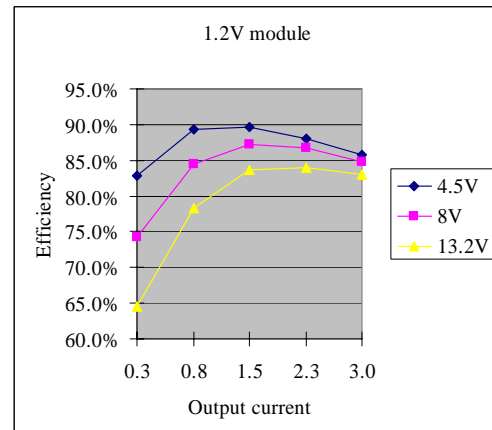
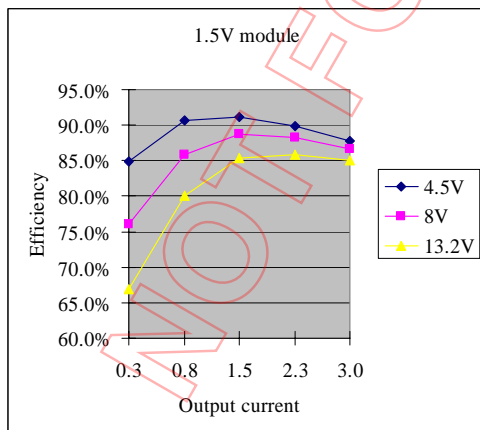
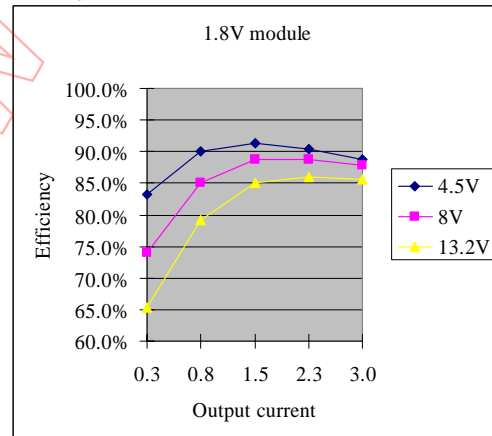
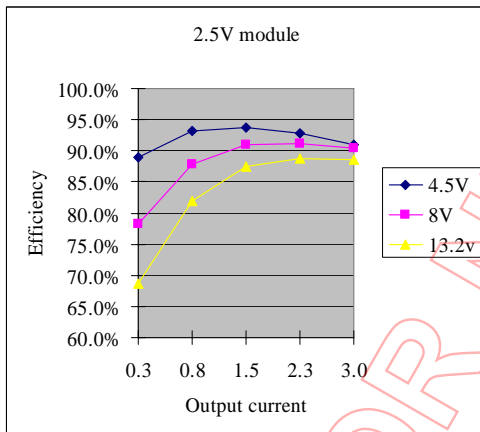
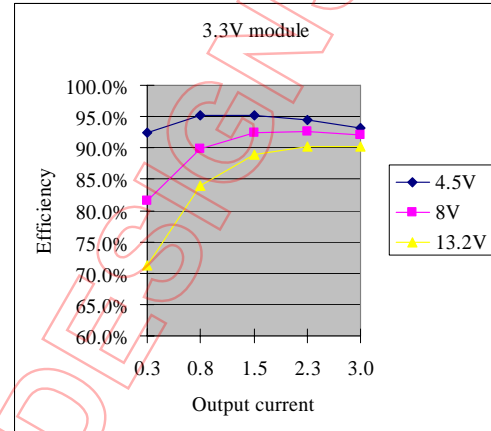
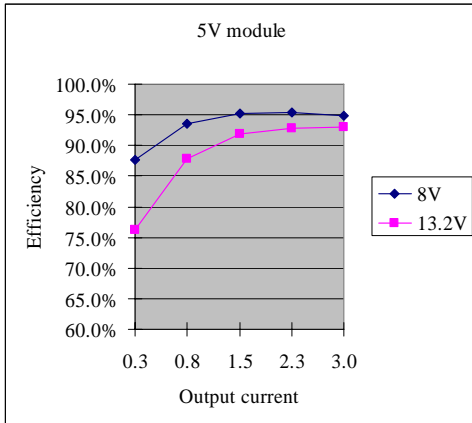

NON-ISOLATED DC/DC CONVERTERS
 4.5 Vdc - 13.2 Vdc Input 0.9 Vdc - 5.0 Vdc/3 A Output



Efficiency Data (continued)

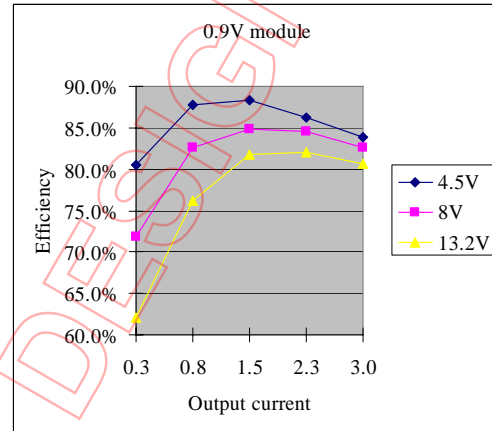
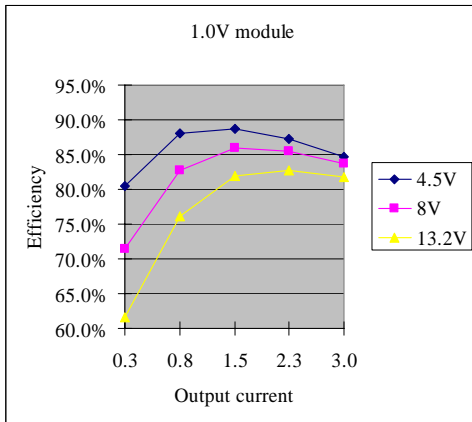

Thermal Derating Curve

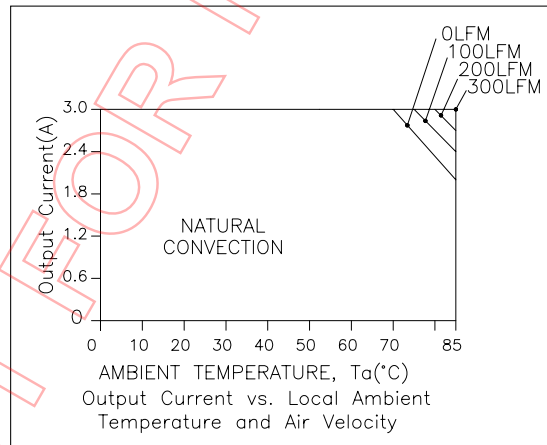

VRAH-03E330

NON-ISOLATED DC/DC CONVERTERS
 4.5 Vdc - 13.2 Vdc Input 0.9 Vdc - 5.0 Vdc/3 A Output



Ripple and Noise Waveforms

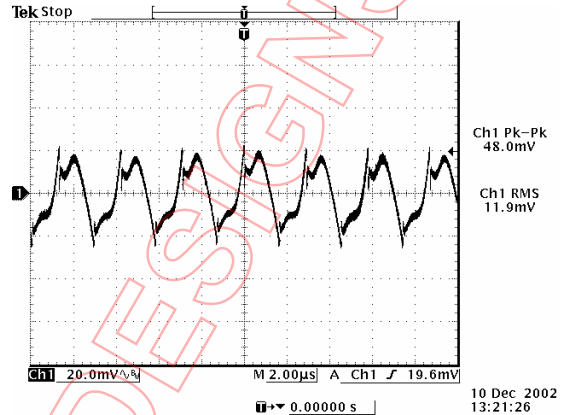
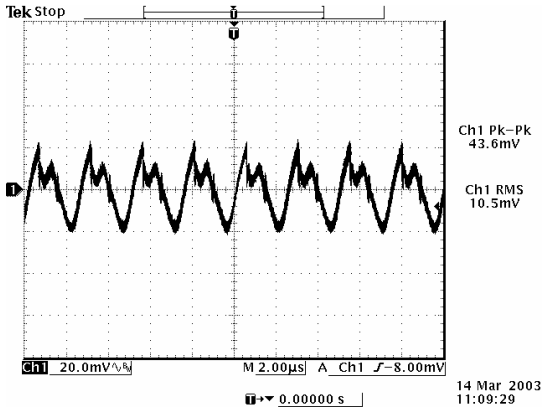

Ripple and noise at max load 5.0 Vdc output

Ripple and noise at max load 3.3 Vdc output

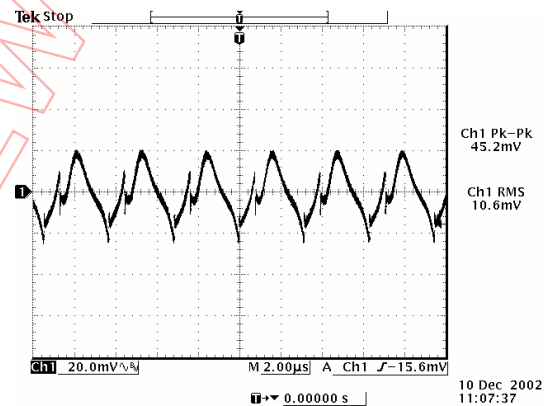
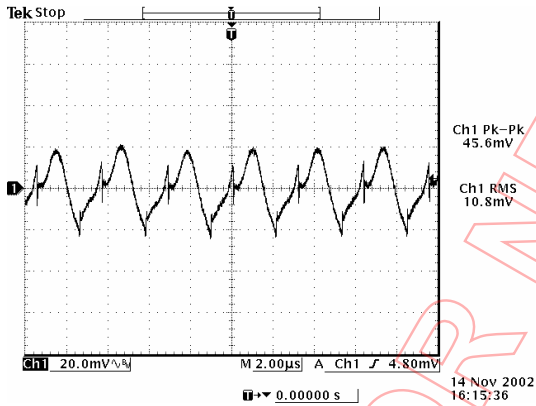

Ripple and noise at max load 2.5 Vdc output

Ripple and noise at max load 1.8 Vdc output

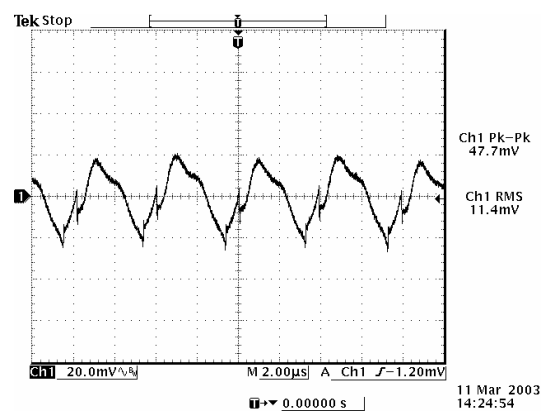
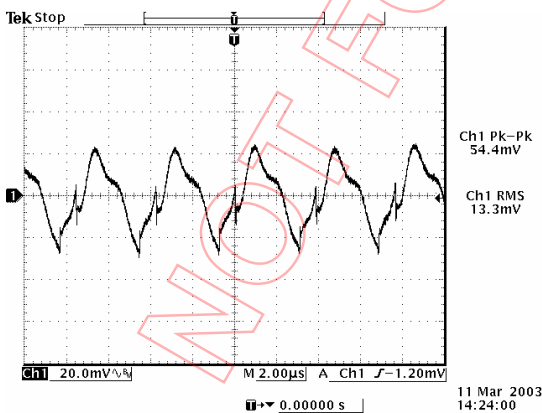

Ripple and noise at max load 1.5 Vdc output

Ripple and noise at max load 1.2 Vdc output

NON-ISOLATED DC/DC CONVERTERS

4.5 Vdc - 13.2 Vdc Input 0.9 Vdc - 5.0 Vdc/3 A Output



Ripple and Noise Waveforms (continued)

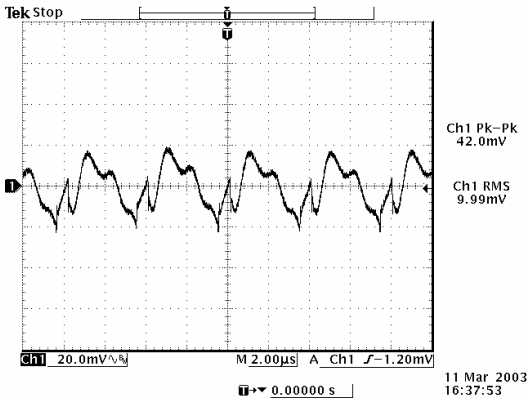

Ripple and noise at max load 1.0 Vdc output

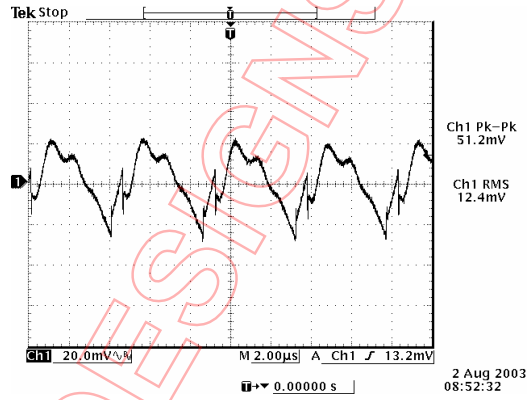

Ripple and noise at max load 0.9 Vdc output

Note: Ripple and Noise at 8 Vdc input, Ta=25 deg C.

Transient Response Waveforms

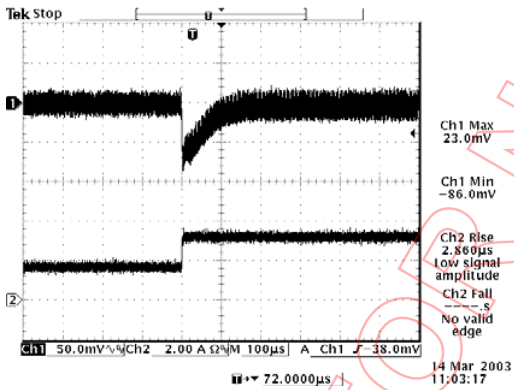

Transients 50% to 100% load 5.0 Vdc output

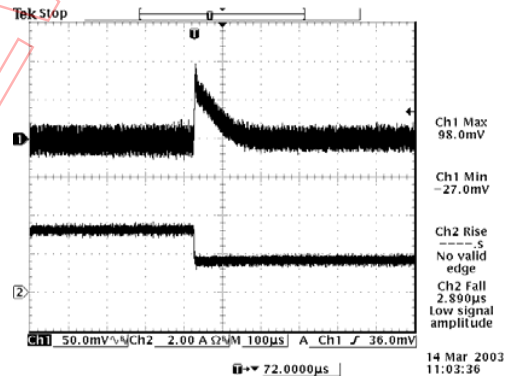

Transients 100% to 50% load 5.0 Vdc output

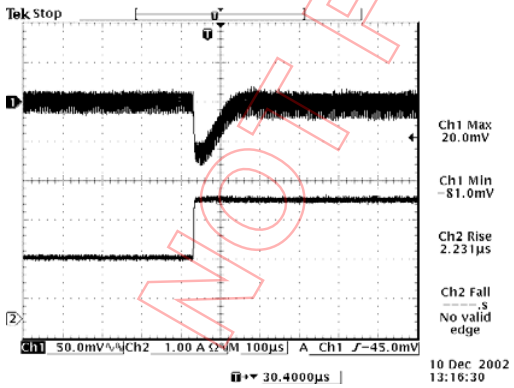

Transients 50% to 100% load 3.3 Vdc output

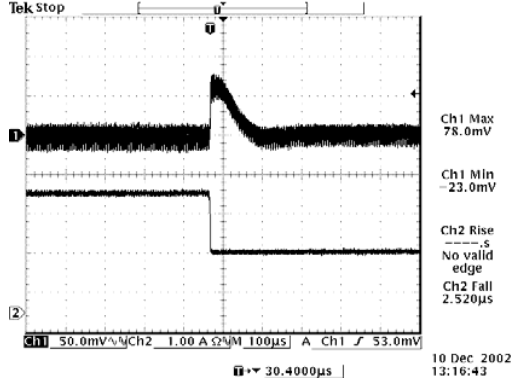

Transients 100% to 50% load 3.3 Vdc output

NON-ISOLATED DC/DC CONVERTERS
 4.5 Vdc - 13.2 Vdc Input 0.9 Vdc - 5.0 Vdc/3 A Output



Transient Response Waveforms (continued)

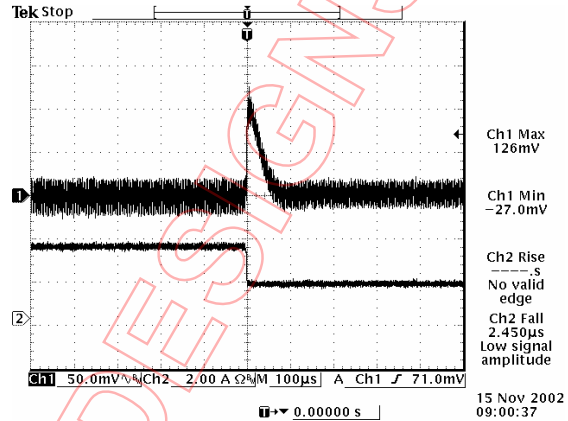
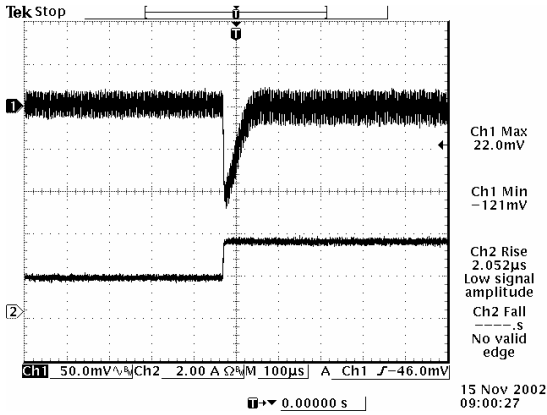

Transients 50% to 100% load 2.5 Vdc output

Transients 100% to 50% load 2.5 Vdc output

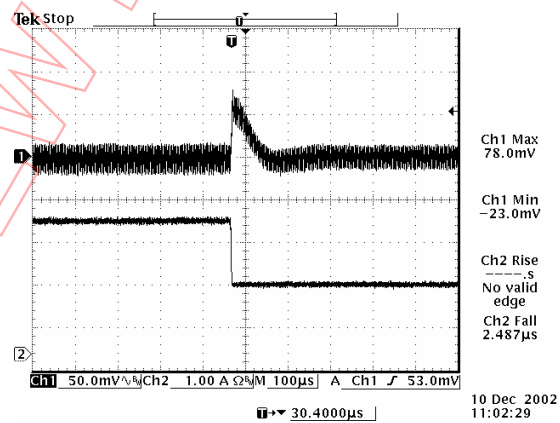
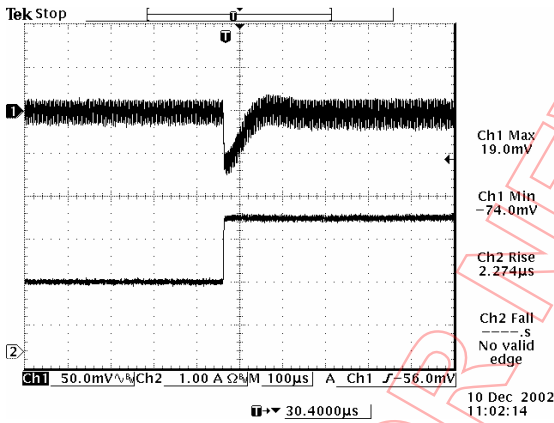

Transients 50% to 100% load 1.8 Vdc output

Transients 100% to 50% load 1.8 Vdc output

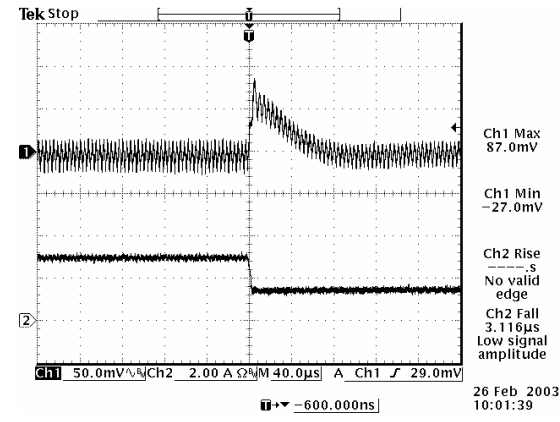
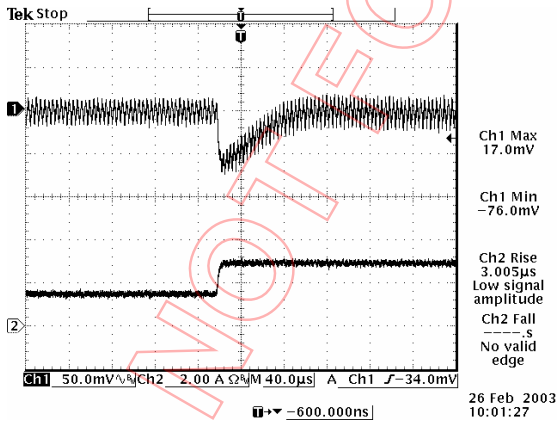

Transients 50% to 100% load 1.5 Vdc output

Transients 100% to 50% load 1.5 Vdc output

NON-ISOLATED DC/DC CONVERTERS

4.5 Vdc - 13.2 Vdc Input 0.9 Vdc - 5.0 Vdc/3 A Output



Transient Response Waveforms (continued)

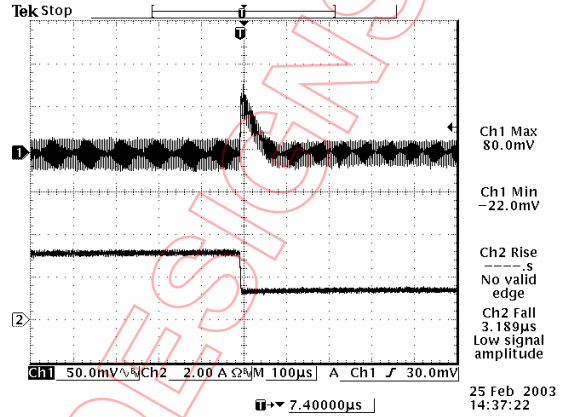
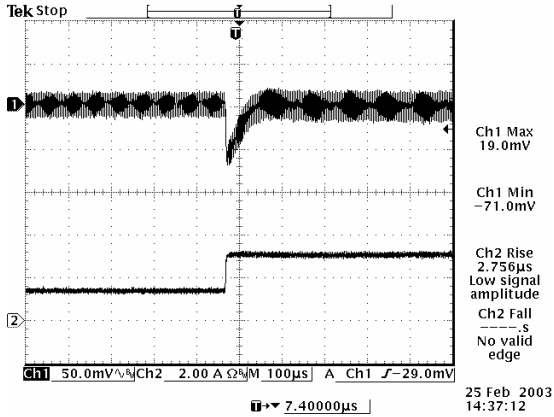

Transients 50% to 100% load 1.2 Vdc output

Transients 100% to 50% load 1.2 Vdc output

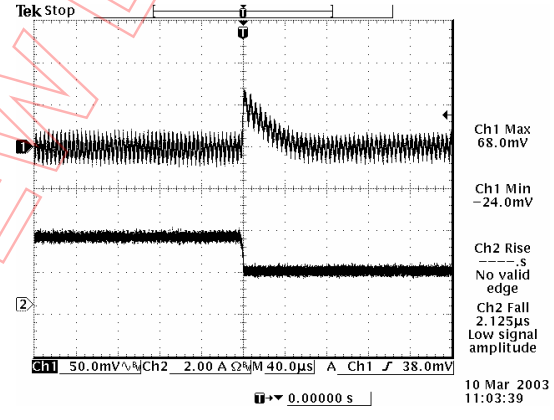
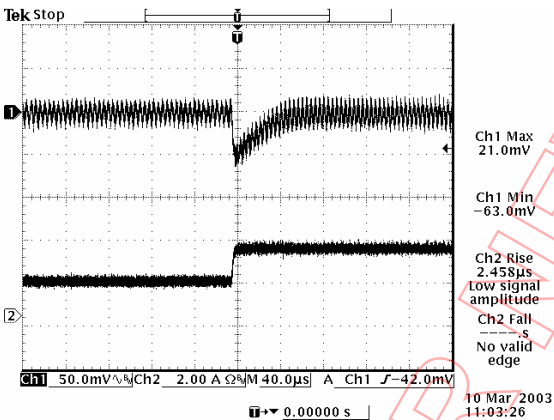

Transients 50% to 100% load 1.0 Vdc output

Transients 100% to 50% load 1.0 Vdc output

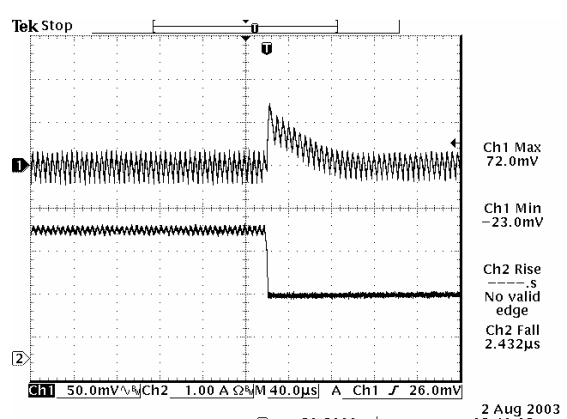
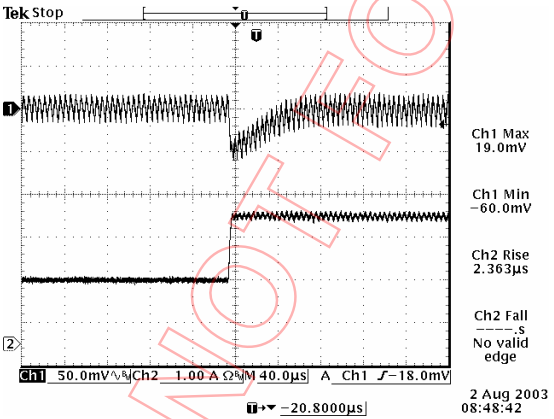

Transients 50% to 100% load 0.9 Vdc output

Transients 100% to 50% load 0.9 Vdc output

Note: Transient Response at 8 V input, di/dt=0.5 A/uS, with 220 uF electric cap at the output.

NON-ISOLATED DC/DC CONVERTERS

4.5 Vdc - 13.2 Vdc Input 0.9 Vdc - 5.0 Vdc/3 A Output



Mechanical Outline

SRAH-03Exx0

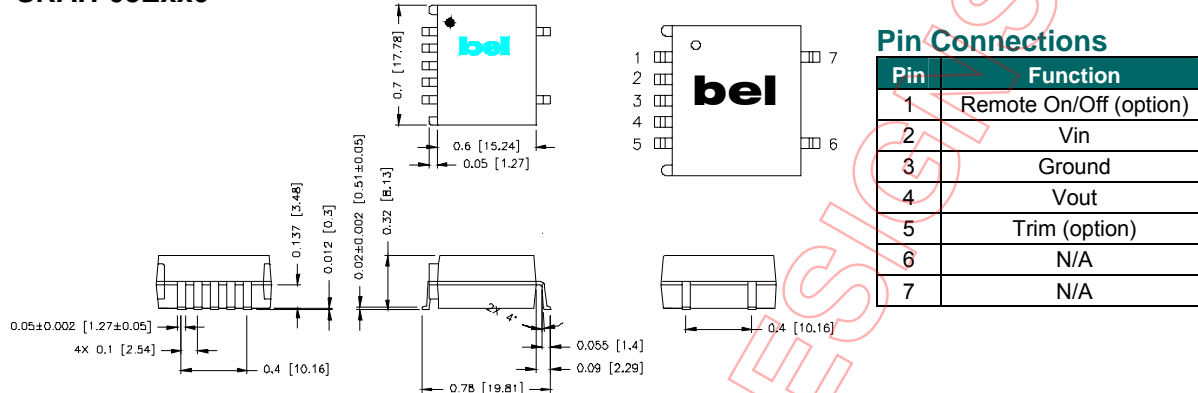

Pin Connections

Pin	Function
1	Remote On/Off (option)
2	Vin
3	Ground
4	Vout
5	Trim (option)
6	N/A
7	N/A

VRAH-03Exx0

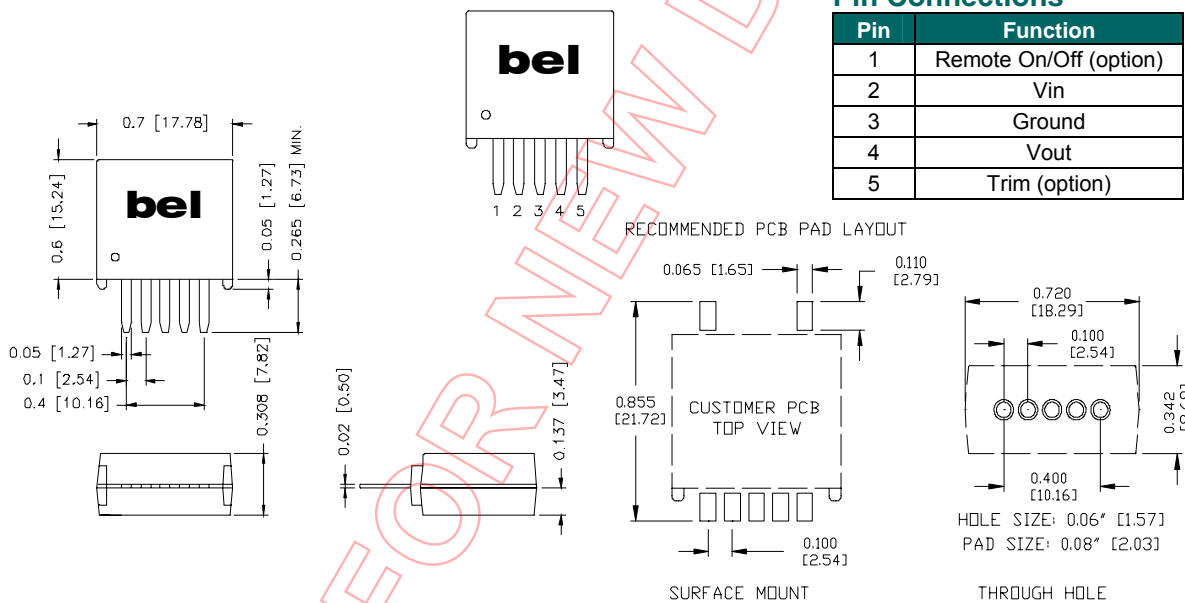

Pin Connections

Pin	Function
1	Remote On/Off (option)
2	Vin
3	Ground
4	Vout
5	Trim (option)

RoHS Compliance

Complies with the European Directive 2002/95/EC, calling for the elimination of lead and other hazardous substances from electronic products. These parts are not however compatible with the higher temperatures associated with lead free solder processes and must be soldered using a reflow profile with a peak temperature of no more than 240 °C.



©2007 Bel Fuse Inc. Specifications subject to change without notice. 010807

CORPORATE

Bel Fuse Inc.
206 Van Vorst Street
Jersey City, NJ 07302
Tel 201-432-0463
Fax 201-432-9542
www.belfuse.com

FAR EAST

Bel Fuse Ltd.
8F/ 8 Luk Hop Street
San Po Kong
Kowloon, Hong Kong
Tel 852-2328-5515
Fax 852-2352-3706
www.belfuse.com

EUROPE

Bel Fuse Europe Ltd.
Preston Technology Management Centre
Marsh Lane, Suite G7, Preston
Lancashire, PR1 8UD, U.K.
Tel 44-1772-556601
Fax 44-1772-888366
www.belfuse.com