

2 mm Square Low-Profile SMT Trimmer Potentiometers (Cermet, Open Frame Type)

Type: **EVM2T**
EVM2N
EVM2W



2T



2N



2W

■ Features

- Low-profile
 - 0.7 mm (0.75 mm max.) EVM2T
 - 0.81 mm (0.95 mm max.) EVM2N
 - 1.05 mm (1.2 mm max.) EVM2W
- Automatic adjustment type (EVM2W)
- High reliability realized by cermet element
- Excellent mountability
- Conforms to JIS C5260-1:1999

■ Recommended Applications

- Audio/visual, office, and communication equipment
- General electronic equipment

■ Explanation of Part Numbers

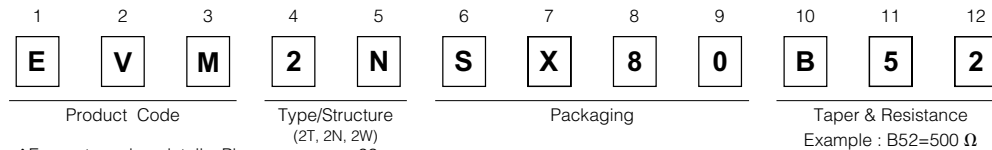

■ Specifications

Total Resistance Value	100 Ω to 1 MΩ
Resistance Tolerance	±25 %
Power Rating	0.15 W
Limiting Element Voltage	50 V
Rotation Torque	EVM2T, EVM2N : 0.5 to 10 mN·m EVM2W : 1 to 15 mN·m
Temperature Coefficient of Resistance	±250 × 10 ⁻⁶ /°C

■ Minimum Quantity/Packing Unit

Part Number	Taping		
	Quantity per reel	Packaging quantity	Dia. of reel (mm)
EVM2T EVM2N EVM2W	3000	15000	φ178

The standard packaging methods for a reel is φ178.

Please contact us, if you would like different packaging methods. (Bulk, Reel of φ330, Reel of φ380)

Design and specifications are each subject to change without notice. Ask factory for the current technical specifications before purchase and/or use. Should a safety concern arise regarding this product, please be sure to contact us immediately.

■ Dimensions in mm (not to scale)

● 3-terminal/Low-profile EVM2T

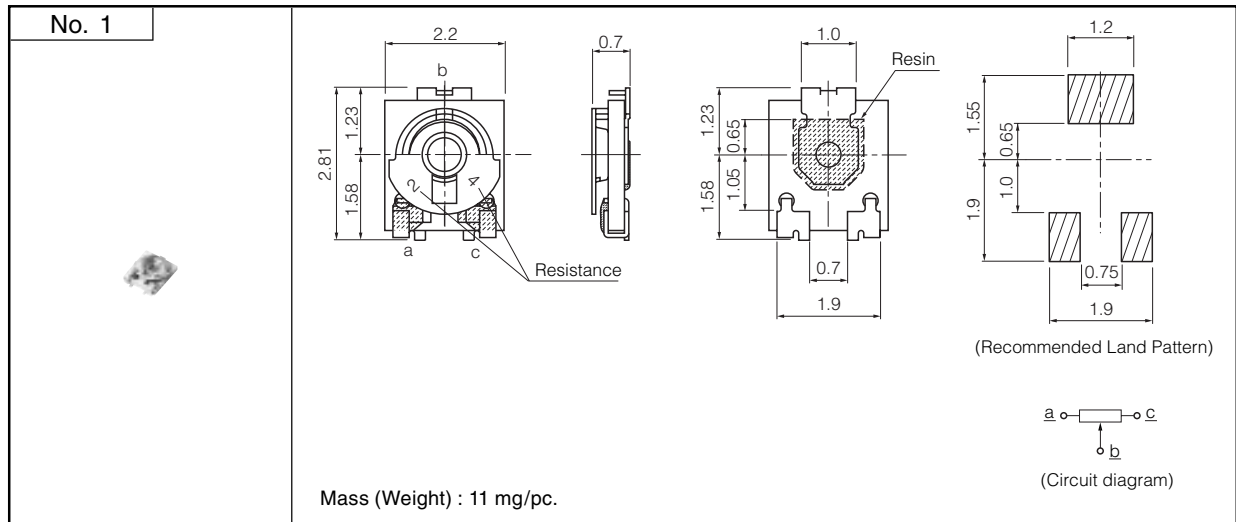

● 3-terminal/Low-profile EVM2N

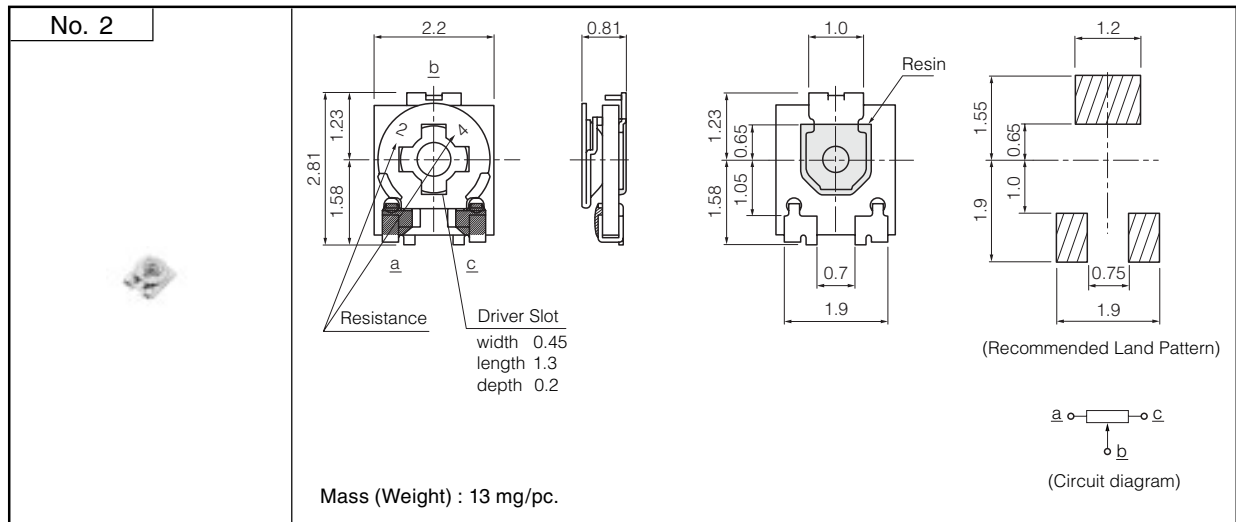

● 3-terminal, for Automatic Trimming Adjustment/Low-profile EVM2W

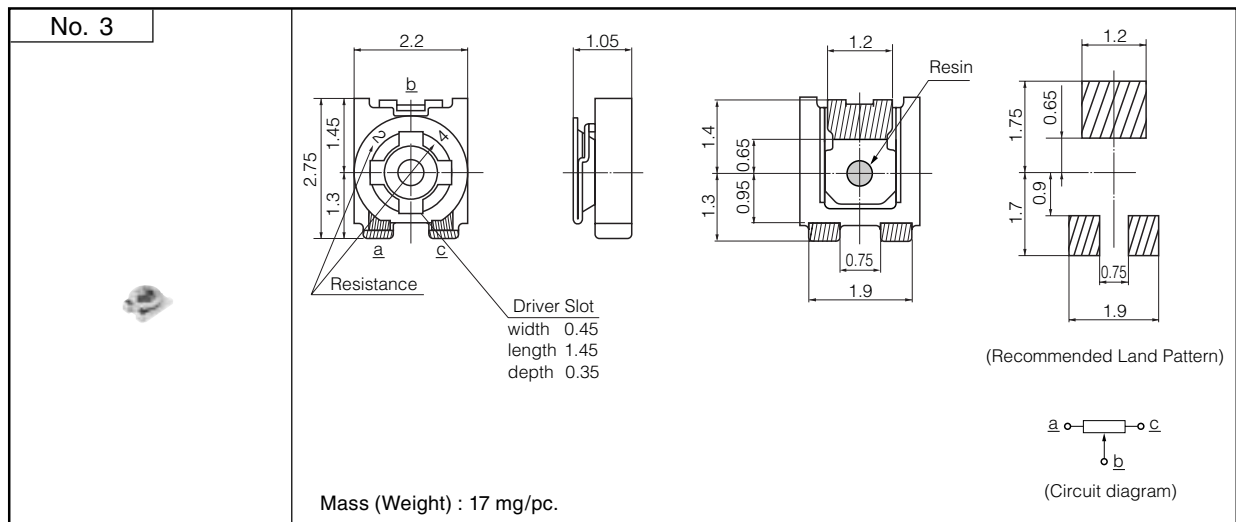

Design and specifications are each subject to change without notice. Ask factory for the current technical specifications before purchase and/or use.
Should a safety concern arise regarding this product, please be sure to contact us immediately.

00 Sep. 2010

■ Explanation of Part Numbers

● SMT Trimmer Potentiometers

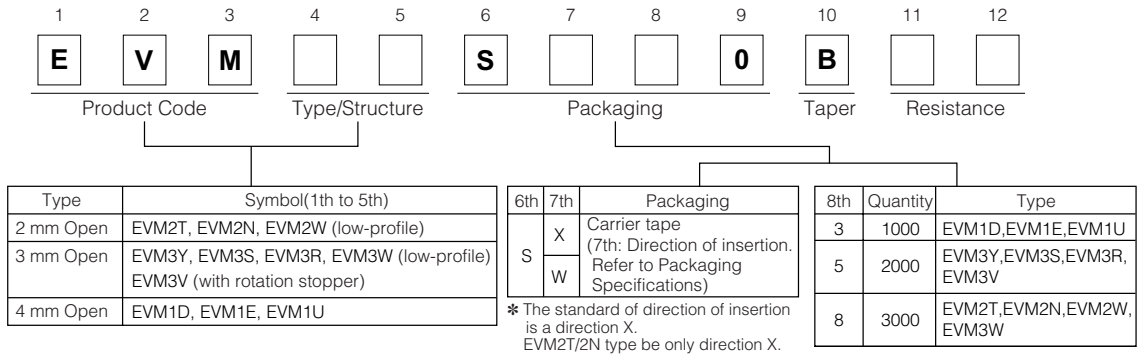

● Ceramic Trimmer Potentiometers

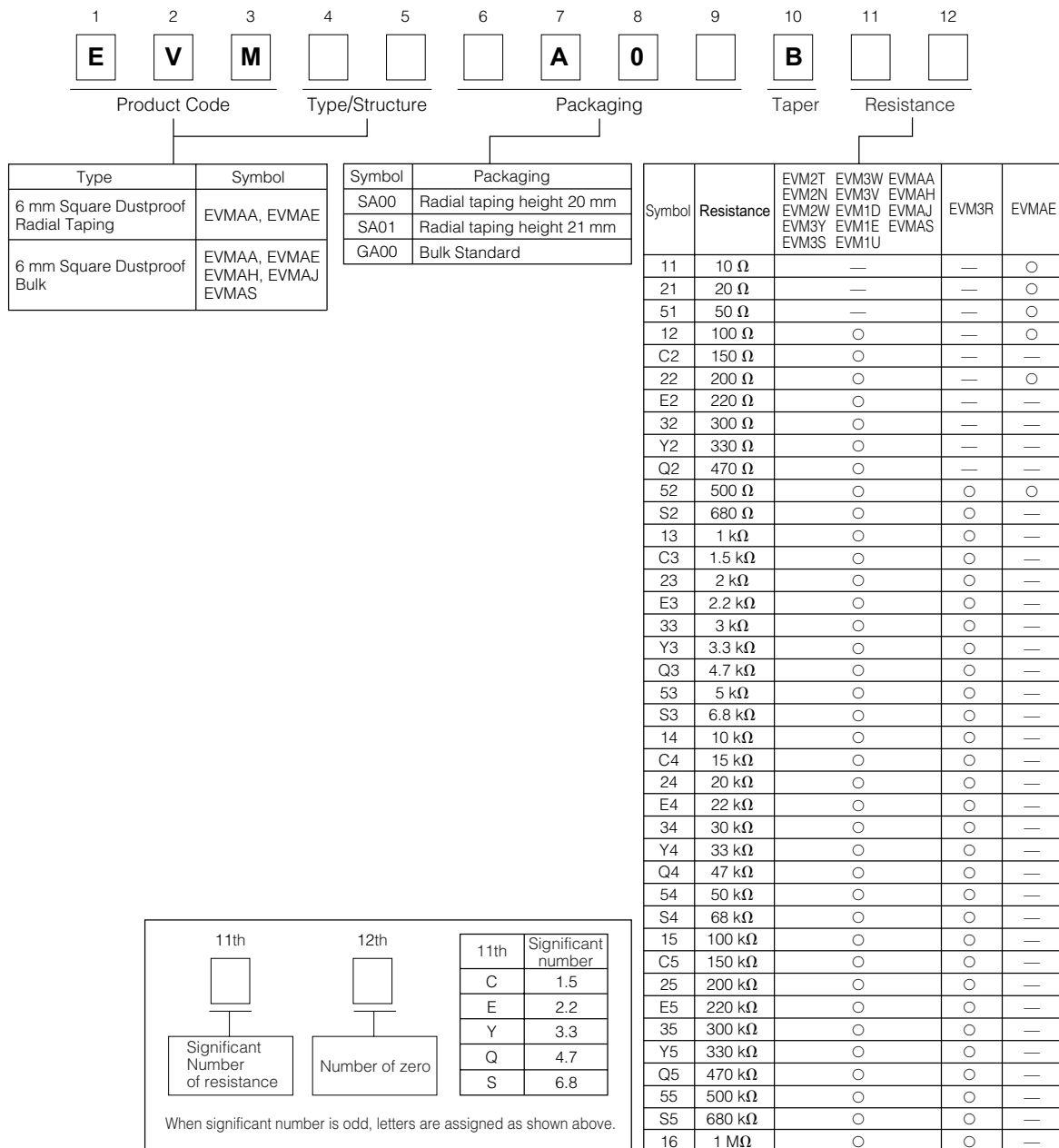

Design and specifications are each subject to change without notice. Ask factory for the current technical specifications before purchase and/or use. Should a safety concern arise regarding this product, please be sure to contact us immediately.