

Features

- Large package size
- For use with precision potentiometers up to 20 turns
- Excellent readability
- Precision feel - no backlash
- Cast housing
- RoHS compliant*

Applications

- Power supplies
- Sensors
- Medical
- Automation
- Test equipment

H-46 Turns-Counting Dial

Mechanical and Physical Characteristics

Number of Turns	0 to 20
Dial Divisions.....	100 per turn
Readability – Over 10 Turns.....	Within 1/100 of a turn
Torque With Brake Engaged	21.18 N-cm (30.0 oz.-in.) maximum
Markings	Black on chrome background
Locking Brake	Yes
Weight.....	73 grams (2.5 oz.)
Set Screw.....	UNC N4-44, one included
Set Screw Tightening Torque.....	16.94 N-cm (1.5 lbs.-in.) minimum
Hex Key Size.....	0.05 in. hex

Shaft and Bushing Requirements

Shaft Diameter Requirements.....	Refer to chart below
Shaft Extension Beyond Panel	17.5 mm (0.689 in.) minimum 23.5 mm (0.925 in.) maximum
Bushing Extension Beyond Panel.....	4.5 mm (0.177 in.) maximum

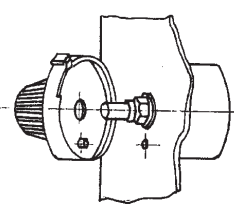

H-46 MOUNTING INSTRUCTIONS

Using the existing Antirotation Lug

1. Drill 3.2 mm (0.125) diameter antirotation pin hole on vertical centerline 14.3 mm (0.562) below center of potentiometer mounting hole.
2. Mount potentiometer shaft counterclockwise to obtain minimum resistance or voltage ratio. This is not necessarily identical with the mechanical stop.
3. Loosen set screws in knob of dial. Set dial to "0.0" reading.
4. While holding outer ring of dial, position unit lightly against panel. Tighten knob set screws to potentiometer shaft.

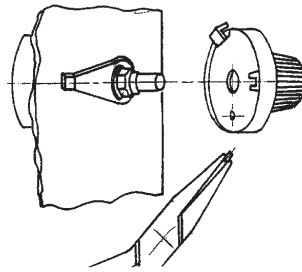

Using the Antirotation Device

1. Remove antirotation lug from dial by using pliers.
2. Mount potentiometer in panel with antirotation device nut (supplied with dial) and lockwasher (supplied with potentiometer).
3. Turn potentiometer shaft counterclockwise to obtain minimum resistance or voltage ratio. This is not necessarily identical with the mechanical stop.
4. Loosen set screws in knob of dial. Set dial to "0.0" reading.
5. While holding outer ring of dial, position unit lightly against panel. Tighten knob set screws to potentiometer shaft.

Dimensional Drawings

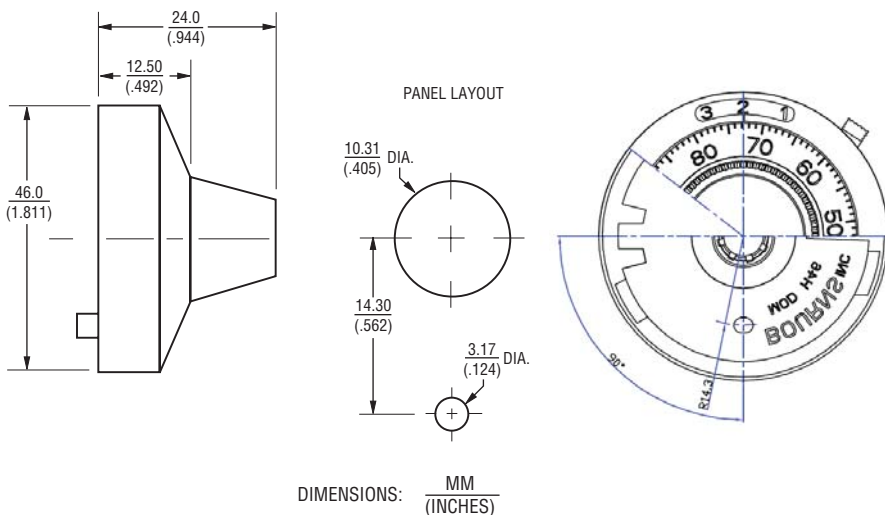

How To Order

Part Number	Accepts Shaft Diameter	Finish
H-46-6A	6.35 mm (.250)	Satin Chrome
H-46-6M	6 mm (.236)	Satin Chrome

REV. 03/09

*RoHS Directive 2002/95/EC Jan 27 2003 including Annex. Specifications are subject to change without notice.

Customers should verify actual device performance in their specific applications