

THIS DRAWING IS UNPUBLISHED. RELEASED FOR PUBLICATION 2008
 COPYRIGHT 2008 BY TYCO ELECTRONICS CORPORATION. ALL RIGHTS RESERVED.

| LOC | DIST | REVISIONS | | | | |
|-----|------|-------------|-------------|-----------|------|------|
| P | LTR | DESCRIPTION | DATE | DWN | APVD | |
| E | B | BA | NEW RELEASE | 30-Jul-08 | SM | ST.P |

- 1 SWITCH TYPE: DPST (4A)
- 2 AVAILABLE IN DIFFERENT SHAFT LENGTHS (L) SEE DATA SHEET
- 3 FOR FURTHER INFORMATION SEE DATA SHEET FOR 23 SERIES-SPINDLE OPERATED POTENTIOMETER

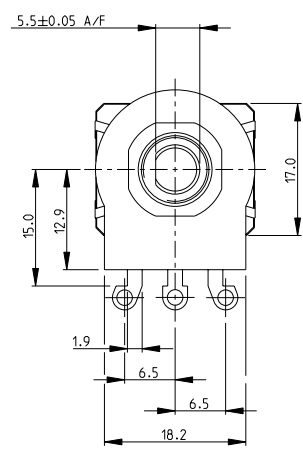
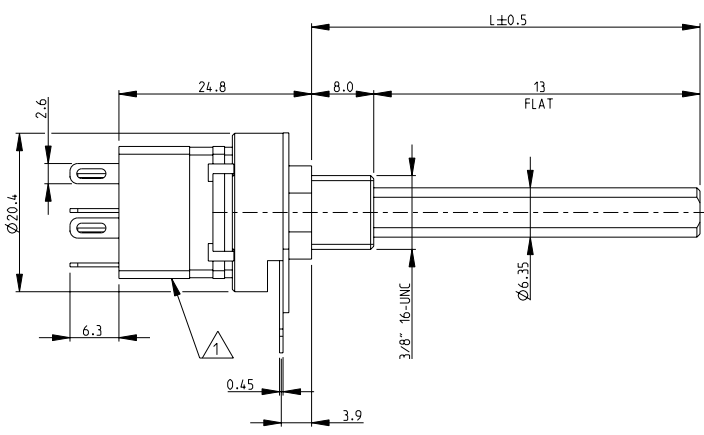

RoHS Compliant

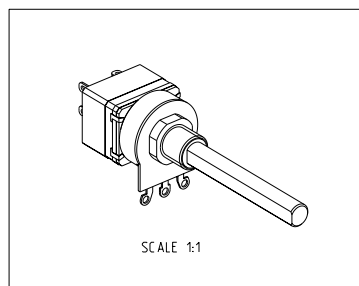

| | | | |
|---|--|--|---|
| <small>THIS DRAWING IS A CONTROLLED DOCUMENT FOR TYCO ELECTRONICS CORPORATION IT IS SUBJECT TO CHANGE AND THE CONTROLLING ENGINEERING ORGANIZATION SHOULD BE CONTACTED FOR THE LATEST REVISION.</small> | | DWN SUBHASH.M 30-Jul-08 CHK PRAKASH.S 30-Jul-08 APVD STEPHEN.P 30-Jul-08 | Tyco Electronics Dorcan, Swindon, SN3 5HH |
| DIMENSIONS: mm | TOLERANCES UNLESS OTHERWISE SPECIFIED: 0 PLC ±0.5 1 PLC ±0.2 2 PLC ±0.1 3 PLC ± 4 PLC ± ANGLES ±5° | NAME SPINDLE OPERATED POTENTIOMETER SERIES 23E PRODUCT SPEC - APPLICATION SPEC - WEIGHT - | SIZE A3 CAGE CODE 00779 DRAWING NO C=1624204 RESTRICTED TO - |
| MATERIAL - | FINISH - | CUSTOMER DRAWING | SCALE 2:1 SHEET 1 OF 1 REV BA |