

Two Axis, Ultra-miniature Joystick With Optional Momentary Switch

Features

- Smallest mini-joystick available (11x11x5 mm)
- Long Life 1 Million Cycles
- Provides excellent electrical accuracy through patented mechanism
- Optional momentary switch is operational at all positions
- RoHS compliant

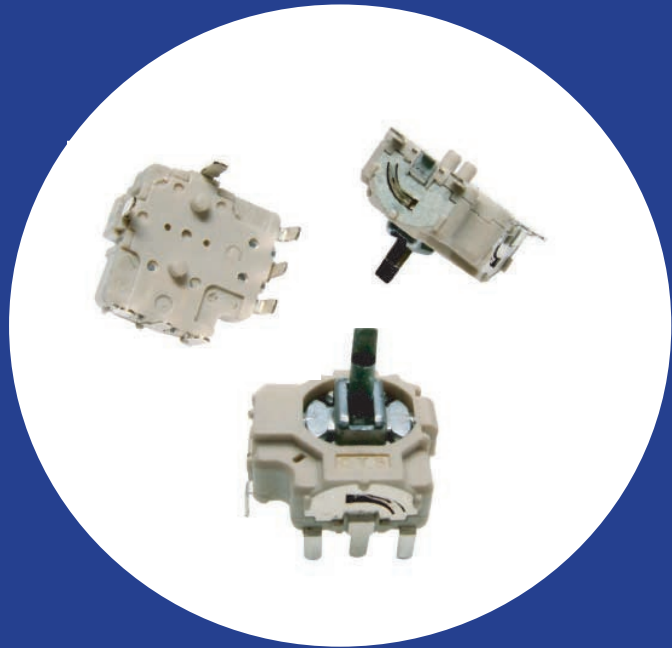

Pat. Nos.: US 7,199,314 , Taiwan 279822, Pat. Pending in China

Electrical and Mechanical Specifications

Potentiometer 1 & 2

Resistance Range

10 K ohms through 100 K ohms

Resistance Tolerance

± 30%, ± 20%, ± 10%

Dielectric Strength

250 VAC 50 / 60 Hz for 1 minute

Insulation Resistance

100 megohms @ 250 VDC for 1 minute

Operational Torque

120 ± 50 gf.cm

Power Rating

0.0125 watt @ 50°C

Maximum Operating Voltage

50 VAC or 5 VDC maximum

Rotational Angle

55°

Life

1,000,000 cycles

Optional Switch

Switch Type

Momentary

Contact Resistance

100 milliohms maximum initially

200 milliohms maximum after 200,000 cycles
switching 5 mA @ 5 VDC

Insulation Resistance

100 megohms minimum @ 100 VDC for 1 minute

Operational Force

650 ± 150 gf

Power Rating

5 VDC, 5 mA maximum

Travel

0.6 ± 0.2mm

Switch Life

200,000 cycles

Electrical and Mechanical Specifications

Potentiometer 1 & 2

Operating Temperature
-10°C to +80°C

Soldering Heat Resistance
260°C for 5 seconds

Mounting Information

Through hole or Surface Mount terminal

CTS Series 254 DIMENSION: mm

Surface Mount Style

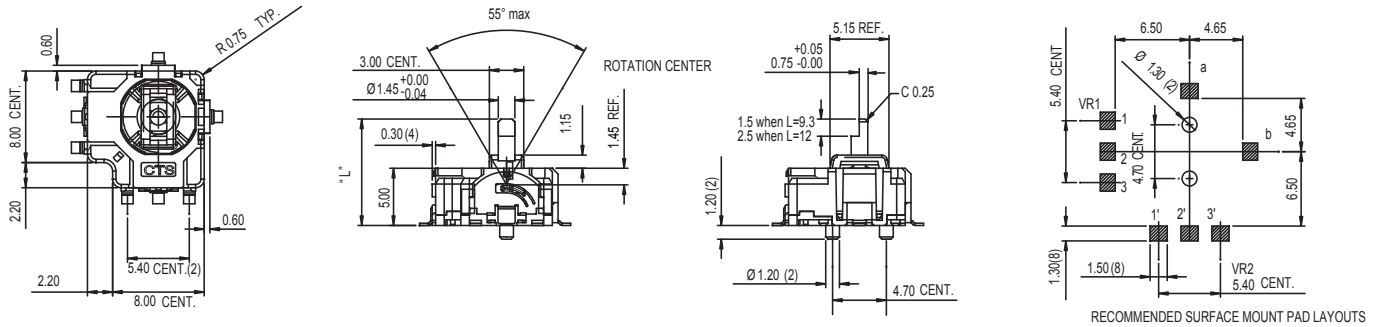

Through Hole Style

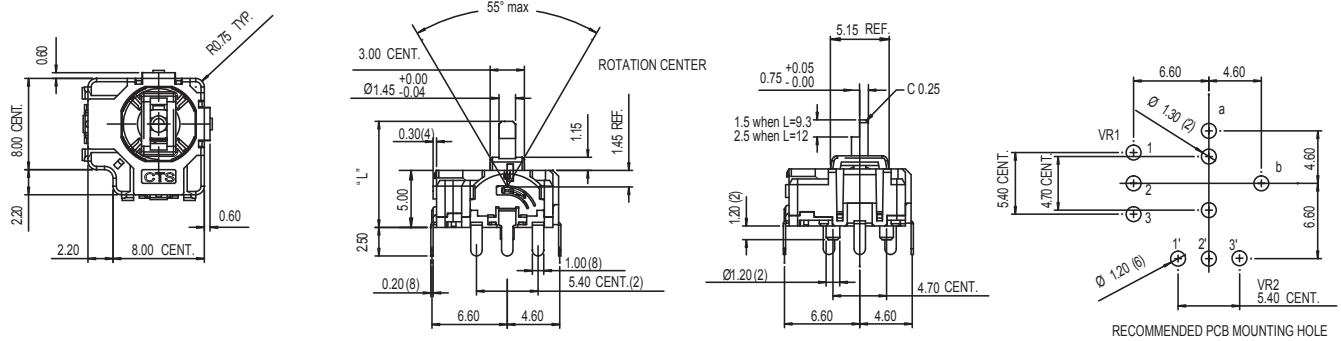

Ordering Information

254

T

B

103

C

50

A

TERMINAL STYLE	DRIVE ARM LENGTH DIM "L"	RESISTANCE CODE EXAMPLES	RESISTANCE TOLERANCE	EFFECTIVE ANGLE	SWITCH CONFIGURATION
S – SURFACE MOUNT T – THROUGH HOLE	LENGTH FROM MOUNTING SURFACE A – 9.3 mm B – 12.0 mm	CODE RESISTANCE 103 10K 104 100K	A – ±10% B – ±20% C – ±30%	50 – 50° 55 – 55°	A – W/O SWITCH B – MOMENTARY SWITCH

STANDARD PART (QUICK DELIVERY) - 254TA103C50A, 254TA103C50B, 254SA103C50A, 254SA103C50B