

### 99-33180 Type Incandescent Subminiature Size T-1

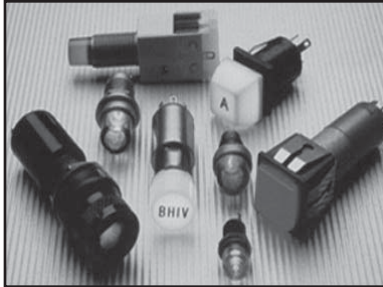

**Material and Finishes**  
Mounting tube, black glass filled nylon per MIL-M-19887. Mounting nut aluminum, black anodized per MIL-A-8625A. Lockwasher, stainless steel or steel, nickel plate. Brass terminals, tin plated per MIL-T-10727A.

**Cap Assembly**  
Lens, high impact-resistant plastic per L-P-349.

**Lamp**  
T-1 sub-midget flange base.

**Mounting**  
Assembly mounts from front of panel. All mounting hardware supplied. Recommended mounting hole .328 in. +.015 in. -.000 in. dia.

**Weight**  
Approx. .12 oz. less lamp

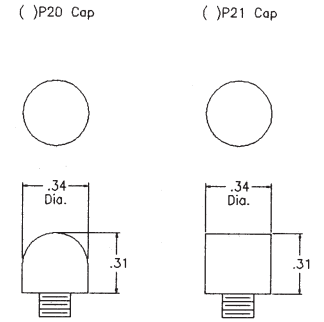
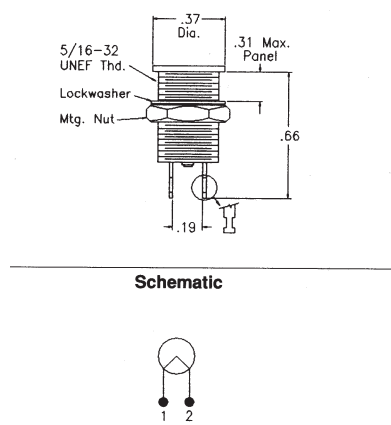

### 11-33480 Type Originally designed to meet MS 25256 Base LH 73/1 Incandescent Miniature Size T-1 3/4

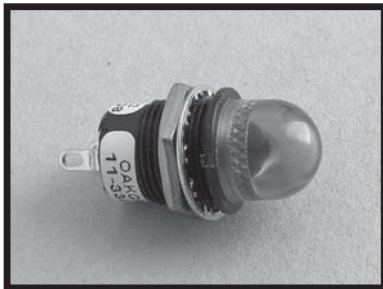

**Material and Finishes**  
Mounting tube and nuts, aluminum, black anodized per MIL-A-8625A. Lockwasher, stainless steel or steel, nickel plate. Brass terminals, tin plated per MIL-T-10727A.

**Cap Assembly**  
Lens, high impact-resistant plastic per L-P-349.

**Lamp**  
T-1 3/4 midget flange base.

**Mounting**  
Assembly mounts from front of panel. All mounting hardware supplied.

**Weight**  
Approximately .2 oz. less lamp.

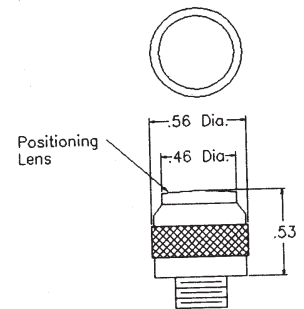
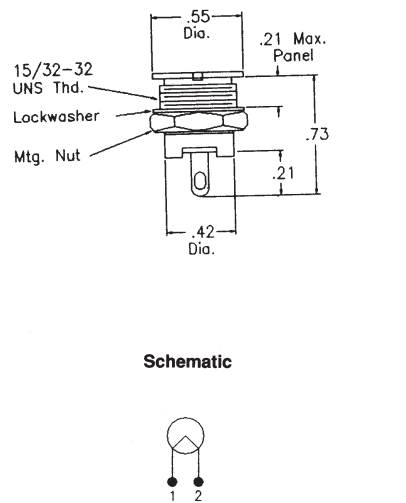

### 14-30080 Type Incandescent Miniature Size T-1 3/4



**Materials and Finishes**  
Mounting tube and nuts, aluminum, black anodized per MIL-A-8625A. Lockwasher, stainless steel or steel, nickel plate. Brass terminals, tin plated per MIL-T-10727A.

**Cap Assembly**  
Lens, high impact-resistant plastic per L-P-349. Lens holders, aluminum, black anodized.

**Lamp**  
T-1 3/4 midget flange base.

**Mounting**  
Assembly mounts from rear of panel. All mounting hardware supplied. Recommended mounting hole .500 in. +/- .015 in. dia.

**Weight**  
Approx. .27 oz. less lamp.

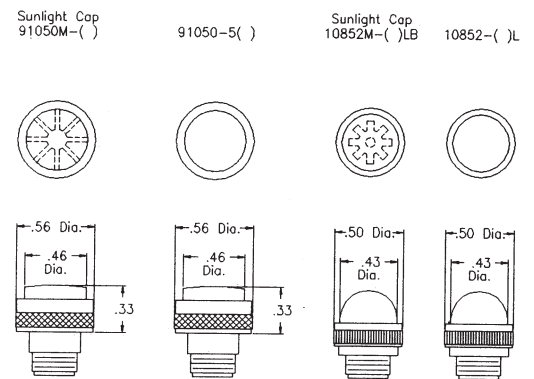
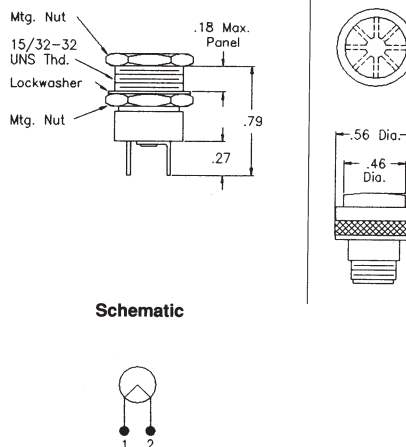

**BASE ASSEMBLY**  
13-30080S

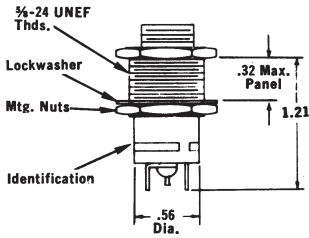

**SCHEMATIC**



**CAP STYLES**

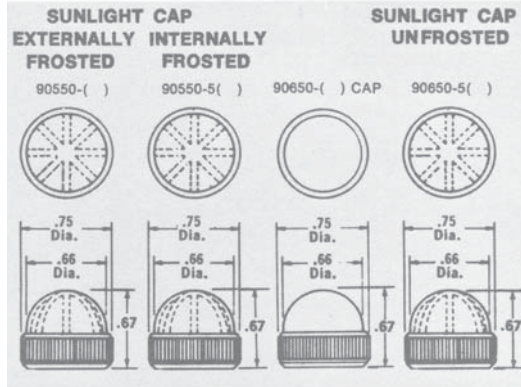

**Materials and Finishes**

Mounting tube and nuts, aluminum, black anodized per MIL-A-8625A. Lockwasher, stainless steel or steel, nickel plate. Brass terminals, tin plated per MIL-T-10727A.

**Cap Assembly**

Lens, high impact-resistant plastic (nylon). Standard colors are semi-diffusing.

**Lamp**

T-3 3/4 miniature bayonet base.

**Mounting**

Assembly mounts from rear of panel. All mounting hardware supplied. Recommended mounting hole .640 in. +/- .015 in. dia.

**13-VM 305 Type**  
**Incandescent General Purpose**  
**Size T-3 3/4**



**BASE ASSEMBLY**  
14-35180

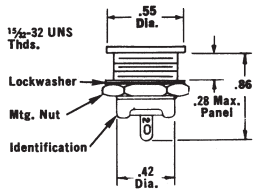

**SCHEMATIC**



**CAP STYLES**

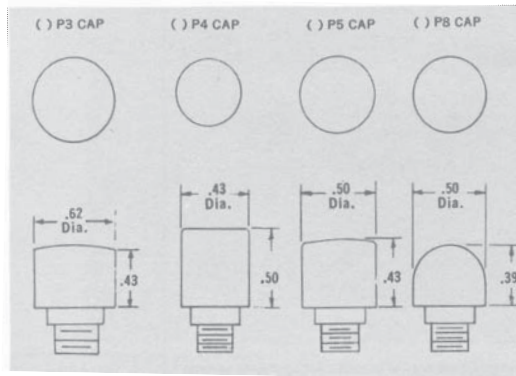

**Materials and Finishes**

Mounting tube and nuts, aluminum, black anodized per MIL-A-8625A. Lockwasher, stainless steel or steel, nickel plate. Brass terminals, tin plated per MIL-T-10727A.

**Cap Assembly**

Lens, high impact-resistant plastic per L-P-349.

**Lamp**

T-1 3/4 midget flange base.

**Mounting**

Assembly mounts from rear of panel. All mounting hardware supplied. Recommended mounting hole .500 in. +/- .015 in. dia.

**Weight**

Approx. .2 oz. less lamp.

**14-35180 Type**  
**Incandescent Miniature**  
**Size T-1 3/4**



**BASE ASSEMBLY**  
14-32280

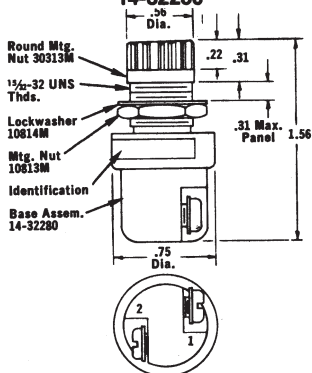

**SCHEMATIC**



**CAP STYLES**

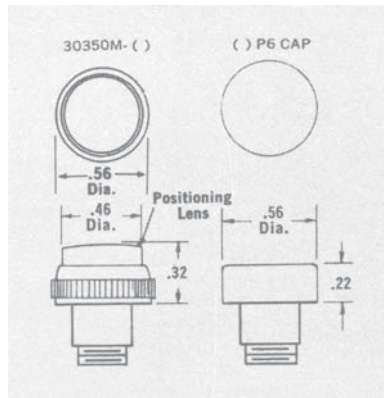

**Materials and Finishes**

Mounting tube and nuts, aluminum, black anodized per MIL-A-8625A. Lockwasher, stainless steel or steel, nickel plate. Terminals 6-32 screws, nickel plate. Round front mounting nut, bright nickel plate.

**Lamp**

T-1 3/4 midget flange base.

**Mounting**

Assembly mounts from rear of panel. All mounting hardware supplied. Recommended mounting hole .500 in. +/- .015 in. dia.

**14-32280 Type**  
**Incandescent Miniature**  
**Size T-1 3/4**



### 59-52480 Type Incandescent Miniature Size T-1 3/4



**Materials and Finishes**  
Mounting tube and nuts, aluminum, black anodized per MIL-A-8625A. Lockwasher, stainless steel or steel, nickel plate. Brass terminals, tin plated per MIL-T-10727A.

**Cap Assembly**  
Lens, high impact-resistant plastic per L-P-349.

**Lamp**  
T-1 3/4 midget flange base.

**Mounting**  
Assembly mounts from rear of panel. All mounting hardware supplied.

**Weight**  
Approx. .2 oz. less lamp.

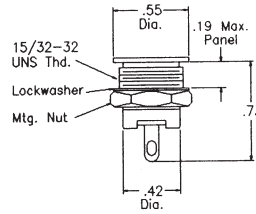

**SCHEMATIC**



Circular



Rectangular



Square

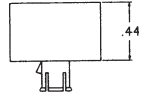
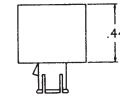
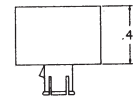
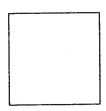

### 33-30881 Type Neon Miniature Size T-2

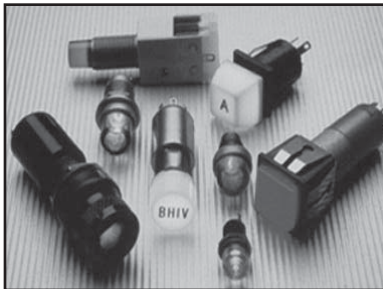

**Materials and Finishes**  
Mounting tube gold anodized, rear mtg. nut aluminum, black anodized per MIL-A-8625A. Lockwasher, stainless steel or steel, nickel plate. Terminals, brass, tin plated per MIL-T-10727A. Round front mtg. nut, bright nickel plate.

**Cap Assembly**  
Lens, high impact-resistant plastic per L-P-349. Standard colors are transparent.

**Lamp**  
A1G (std.) or A1H (high brightness) T-2 neon is furnished with each assembly.

**Mounting**  
Assembly mounts from rear of panel. All mounting hardware supplied. Recommended mounting hole .500 in. +/- .015 in. dia.

**Weight**  
Approx. .35 oz. less lamp.

#### BASE ASSEMBLY

33-30881 (68KΩ Internal Resistor)

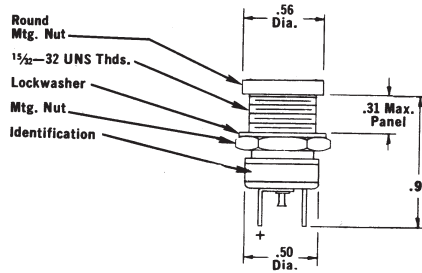

**SCHEMATIC**



#### CAP STYLES

