

**ATTENTION:**  
OBSERVE PRECAUTIONS FOR  
HANDLING ELECTROSTATIC  
SENSITIVE DEVICES

REV	ECN NO	REVISIONS	DRN	CKD	APP	DATE
02	—	PRELIMINARY	KLJ			

NOTES:

1. WIRE LEADS: 18 AWG
2. THIS ASSEMBLY CONTAINS ELECTROSTATIC DISCHARGE SENSITIVE DEVICES (ESDS). MAINTAIN ALL PRECAUTIONARY MEASURES DURING ASSEMBLY, HANDLING, AND STORAGE IN ACCORDANCE WITH IPC-A-610.

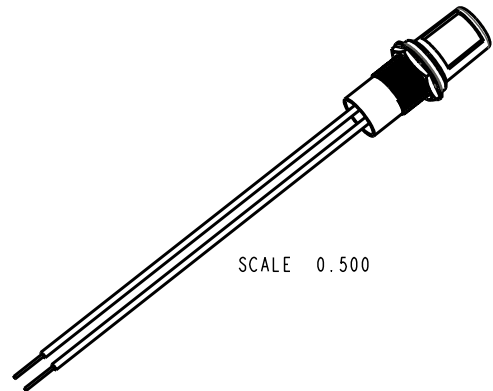
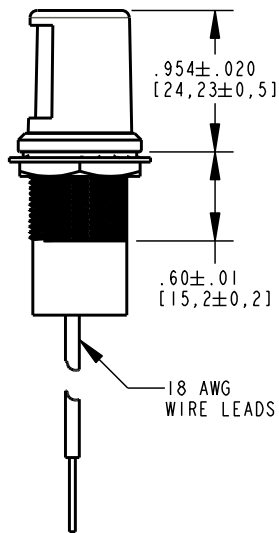
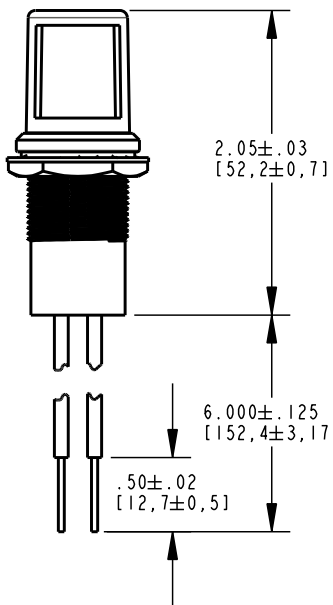

**RoHS COMPLIANT**

Part Numbers with the "F" suffix ending are RoHS Compliant. Packaging is marked with "RoHS Compliant" label or equivalent markings.

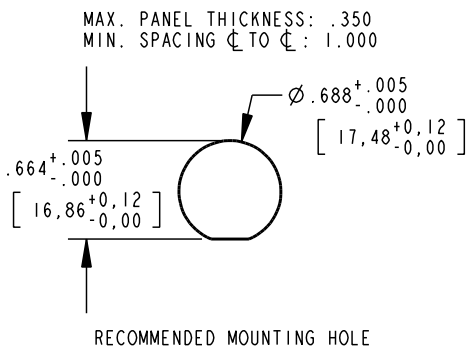
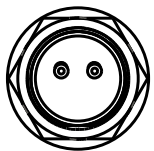

THIS DRAWING AND THE CONTENTS HEREIN ARE CONFIDENTIAL AND THE SOLE PROPERTY OF DIALIGHT. REPRODUCTION OF THIS DRAWING OR CONSTRUCTION OF ANY PARTS WITHIN THIS DRAWING ARE FORBIDDEN WITHOUT THE WRITTEN CONSENT OF DIALIGHT.		
SCALE: 1.000	DRAWING NUMBER	REV
ALL DIM'S IN: INCHES (MM)	C-17624	02
TOLERANCES: UNLESS OTHERWISE SPECIFIED	TITLE	
FRACTIONS: $\pm 1/64$	657 RIGHT ANGLE LENS LED PMI	
DECIMALS (.XX): $\pm .01$	MATERIAL	
DECIMALS (.XXX): $\pm .005$	-	
DECIMALS (.XXXX): $\pm .0005$	-	
ANGLES: $\pm 1^\circ$	-	
FINISH:	-	
FSCM 83330	<b>Dialight</b>	1501 ROUTE 34 SOUTH FARMINGDALE, NJ 07727
	SHEET 1 OF 1	FAMILY TABLE: