

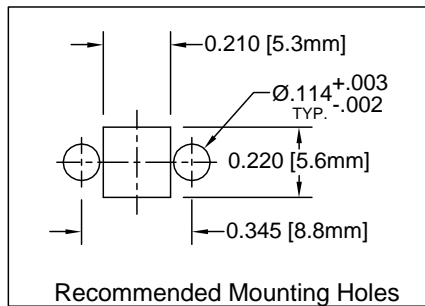

REV.	DESCRIPTION	DATE	APPROVED
C	Engineering Update w/o Changes	03/08/04	M. C.

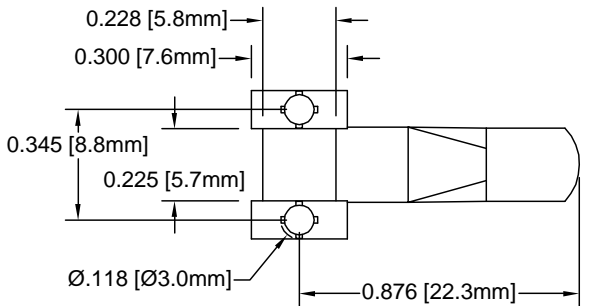
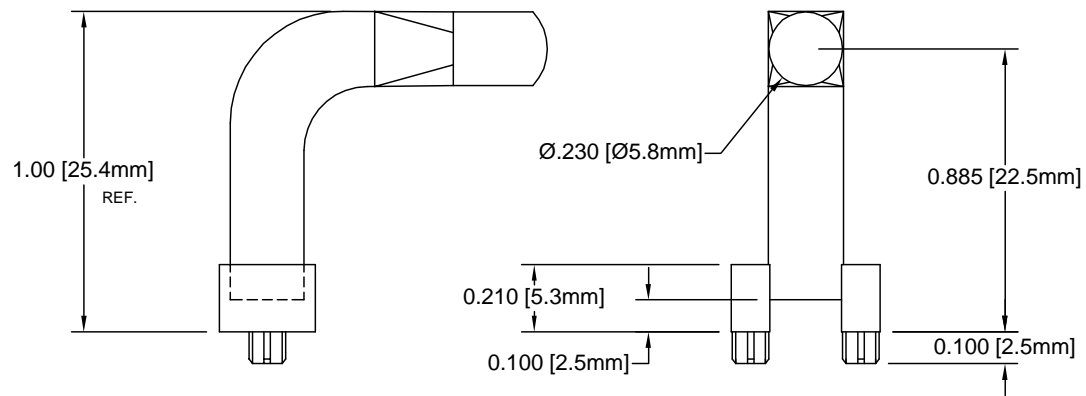

- 2. MATERIAL: POLYCARBONATE 94V-0 CLEAR, BIVAR MATERIAL CODE 47-CR.
SAMYANG CORPORATION POLYCARBONATE 3025N2 CLEAR
- 1. GENERAL SPECIFICATIONS: BIVAR MOLDED COMPONENT SPECIFICATION BV00-E101.

STANDARD TOLERANCE (UNLESS OTHERWISE SPECIFIED)		 4 THOMAS, IRVINE, CA. 92618 TEL: (949) 951-8808 FAX: (949) 951-3974	
DECIMALS	ANGULAR		
.X ± .1	X° ± 1°	 TITLE: LIGHT PIPE, 90° SURFACE MOUNT	REVISION: C
.XX ± .01			
.XXX ± .005		DESIGNED: Shane Irving	DATE: 06/12/00
		CHECKED: M. Chen	DATE: 07/23/01
		CAGE CODE: 32559	SHEET # 1 OF 1
CAD GENERATED DOCUMENT. DO NOT MEASURE DRAWING.			