

REV.	DESCRIPTION	DATE	APPROVED
G	Mounting Hole Tolerance Update	01/14/10	T. Y.

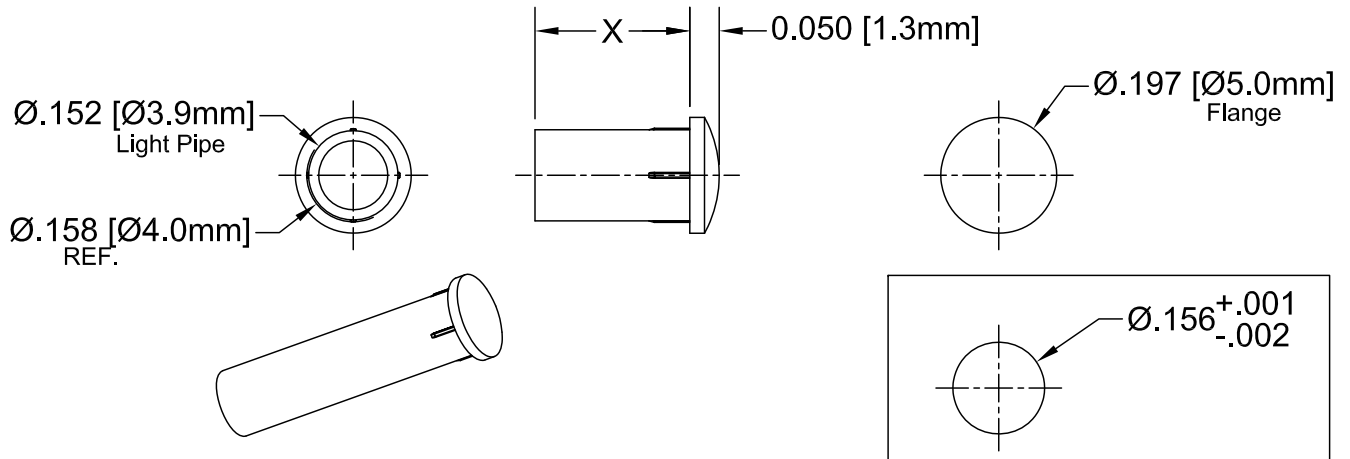

Part No.	X = Body Length
PLP5-2-125	0.125 (3.2mm)
PLP5-2-250	0.250 (6.4mm)
PLP5-2-350	0.350 (8.9mm)
PLP5-2-375	0.375 (9.5mm)
PLP5-2-500	0.500 (12.7mm)
PLP5-2-625	0.625 (15.9mm)
PLP5-2-750	0.750 (19.0mm)
PLP5-2-1000	1.000 (25.4mm)
PLP5-2-1250	1.250 (31.8mm)
PLP5-2-1500	1.500 (38.1mm)

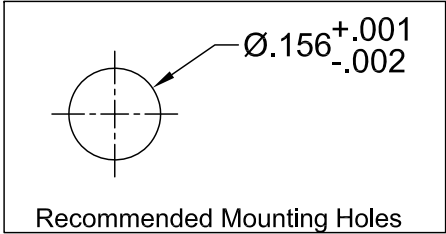

- 2. MATERIAL: POLYCARBONATE, 94V-0, CLEAR. BIVAR MATERIAL CODE 47-CR. SAM YANG CORPORATION POLYCARBONATE 3025N2 CLEAR.
- 1. GENERAL SPECIFICATIONS: BIVAR MOLDED COMPONENT SPECIFICATION BV00-E101.

STANDARD TOLERANCE (UNLESS OTHERWISE SPECIFIED)		 4 THOMAS, IRVINE, CA, 92618 TEL: (949) 951-8808 FAX: (949) 951-3974	
DECIMALS	ANGULAR		
.X ±.1	X° ± 1°	TITLE: PRESS-FIT PANEL MOUNT LIGHT PIPE, LOW PROFILE ROUND, 5mm	
.XX ±.01			
.XXX ±.005			
DESIGNED: Michael Chen	DATE: 03/05/03	PART NO: PLP5-2-XXX	REVISION: G
CHECKED: D. Green	DATE: 03/05/03	CAGE CODE : 32559	SHEET # 1 OF 1
CAD GENERATED DOCUMENT, DO NOT MEASURE DRAWING.			