

UNCONTROLLED DOCUMENT

PART NUMBER
SSP-13MDB152UP12G

REV.
D

REV.	E.C.N. NUMBER AND REVISION COMMENTS	DATE
A	E.C.N. #10950.	1.28.03
B	E.C.N. #10993.	5.21.03
C	E.C.N. #11260.	7.18.05
D	E.C.N. #11148.	11.30.06

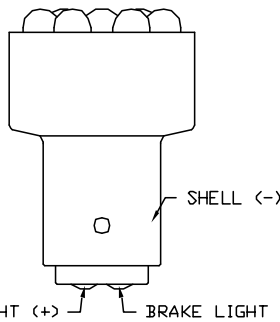
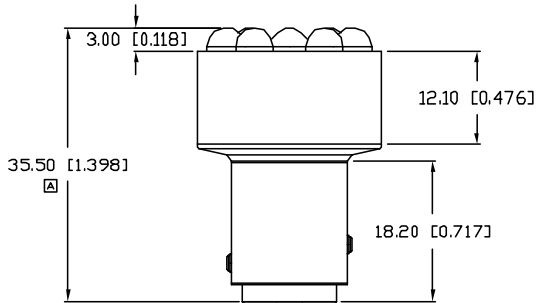
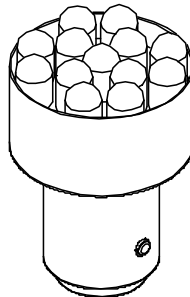
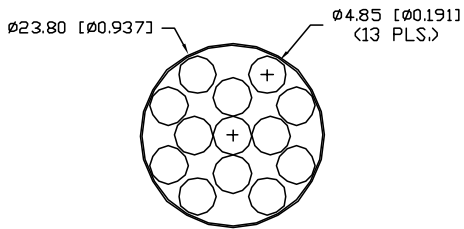

⊠ ELECTRO-OPTICAL CHARACTERISTICS $T_A=25^\circ\text{C}$ $V_f=12\text{V}$

PARAMETER	MIN	TYP	MAX	UNITS	TEST COND
PEAK WAVELENGTH		525		nm	
FORWARD VOLTAGE		12.0		V_f	
REVERSE VOLTAGE	5.0			V_r	$I_f=100\mu\text{A}$
AXIAL INTENSITY *	99,100/33,000			mcd	$V_f=12\text{V}$
VIEWING ANGLE		30		2x theta	

EMITTED COLOR: GREEN
EPOXY LENS FINISH: WATER CLEAR
*STOP/RUN

LIMITS OF SAFE OPERATION AT 25°C

PARAMETER	MAX	UNITS
PEAK FORWARD VOLTAGE	14.0	V
STEADY CURRENT	90	mA
POWER DISSIPATION	1,260	mW
DERATE FROM 25°C	-1.2	$\text{mW}/^\circ\text{C}$
OPERATING, STORAGE TEMP.	-40 TO +85	$^\circ\text{C}$

*UNLESS OTHERWISE SPECIFIED TOLERANCES PER DECIMAL PRECISION ARE: X=±1 (±0.039), XX=±0.5 (±0.020), XXX=±0.25 (±0.010), XXXX=±0.127 (±0.005). LEAD SIZE=±0.05 (±0.002), LEAD LENGTH=±0.75 (±0.030). MIN= +DECIMAL PRECISION -0.00, MAX.= -DECIMAL PRECISION

REV. D	PART NUMBER SSP-13MDB152UP12G
0.94" CIRCULAR, 13 LAMP POLYLED, GREEN, 1157 BASE, DOUBLE CONTACT AUTO BAYONET.	

CONFIDENTIAL INFORMATION
THE INFORMATION CONTAINED IN THIS DOCUMENT IS THE PROPERTY OF SUNBRITE LEDS. EXCEPT AS SPECIFICALLY AUTHORIZED IN WRITING BY SUNBRITE LEDS, THE HOLDER OF THIS DOCUMENT SHALL KEEP ALL INFORMATION CONTAINED HEREIN CONFIDENTIAL AND SHALL PROTECT SAME IN WHOLE OR IN PART FROM DISCLOSURE AND DISSEMINATION TO ALL THIRD PARTIES.

RELIABILITY NOTE
OUR MANY YEARS OF EXPERIENCE DATA ACCUMULATION INDICATE THAT SOLDER HEAT IS A MAJOR CAUSE OF EARLY AND FUTURE FAILURE. PLEASE PAY ATTENTION TO YOUR SOLDERING PROCESS.

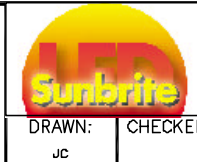

286 E. HELEN ROAD
PALATINE, IL 60067-6976
PHONE: +1.847.348.3116
FAX: +1.847.359.2867
WEB: www.sunbriteleds.com

DRAWN: jc	CHECKED:	APPROVED:	DATE: 11.30.06 PAGE: 1 OF 1
--------------	----------	-----------	--------------------------------

UNCONTROLLED DOCUMENT

