

UNCONTROLLED DOCUMENT

CAUTION: STATIC SENSITIVE DEVICE
FOLLOW PROPER E.S.D. HANDLING PROCEDURES
WHEN WORKING WITH THIS PART.

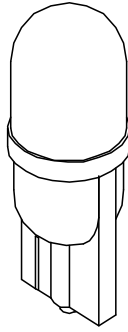
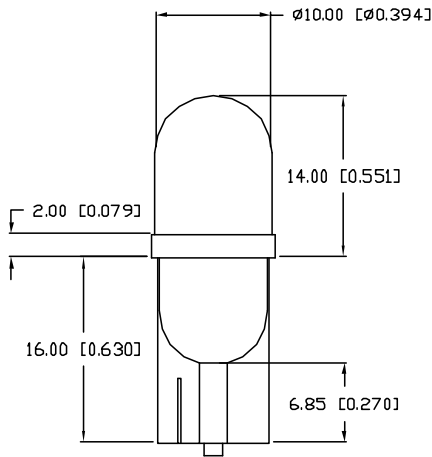

PART NUMBER		REV.
SSP-01TWB7UW12		B
REV.	E.C.N. NUMBER AND REVISION COMMENTS	DATE
A	E.C.N. #10897.	7.30.02
B	E.C.N. #11148	11.16.06

ELECTRO-OPTICAL CHARACTERISTICS $T_A=25^{\circ}\text{C}$ $V_f=12\text{V}$

PARAMETER	MIN	TYP	MAX	UNITS	TEST COND
PEAK WAVELENGTH		470		nm	
FORWARD VOLTAGE		12	14.0	V_f	
REVERSE VOLTAGE	5.0			V_r	$I_r=100\mu\text{A}$
AXIAL INTENSITY		1600		mcd	$V_f=12\text{V}$
VIEWING ANGLE		60		2x theta	
EMITTED COLOR:	SUPER BLUE				
EPOXY LENS FINISH:	MILKY WHITE DIFFUSED				

LIMITS OF SAFE OPERATION AT 25°C PER DIE

PARAMETER	MAX	UNITS
PEAK FORWARD VOLTAGE	14	V
STEADY CURRENT	20	mA
POWER DISSIPATION	105	mW
DERATE FROM 25°C	-1.2	mW/°C
OPERATING, STORAGE TEMP.	-40 TO +85	°C



UNCONTROLLED DOCUMENT

*UNLESS OTHERWISE SPECIFIED TOLERANCES PER DECIMAL PRECISION ARE: X=#1 (±0.039), XX=#0.5 (±0.020), XXX=#0.25 (±0.010), XXXX=#0.127 (±0.005). LEAD SIZE=#0.05 (±0.002), LEAD LENGTH=#0.75 (±0.030). MIN= +DECIMAL PRECISION -0.00 MAX.= +0.00 -DECIMAL PRECISION

REV. B	PART NUMBER SSP-01TWB7UW12	<p>CONFIDENTIAL INFORMATION THE INFORMATION CONTAINED IN THIS DOCUMENT IS THE PROPERTY OF SUNBRITE LEDS. EXCEPT AS SPECIFICALLY AUTHORIZED IN WRITING BY SUNBRITE LEDS, THE HOLDER OF THIS DOCUMENT SHALL KEEP ALL INFORMATION CONTAINED HEREIN CONFIDENTIAL AND SHALL PROTECT SAME IN WHOLE OR IN PART FROM DISCLOSURE AND DISSEMINATION TO ALL THIRD PARTIES.</p> <p>RELIABILITY NOTE OUR MANY YEARS OF EXPERIENCE DATA ACCUMULATION INDICATE THAT SOLDER HEAT IS A MAJOR CAUSE OF EARLY AND FUTURE FAILURE. PLEASE PAY ATTENTION TO YOUR SOLDERING PROCESS.</p>	<p>286 E. HELEN ROAD PALATINE, IL 60067-6976 PHONE: +1.847.359.2790 FAX: +1.847.359.2867 WEB: www.sunbriteleds.com</p>
LED MINATURE WEDGE BASE, BLUE, MILKY WHITE DIFFUSED.		DRAWN: JC CHECKED: APPROVED: DATE: 11.16.06 PAGE: 1 OF 1	