

Data Sheet



Description

The ACPL-824 is an AC-input dual channel full-pitch phototransistor optocoupler which contains four light emitting diode optically coupled to two separate phototransistor. It is packaged in a 8-pin DIP package.

Likewise, the ACPL-844 is an AC-input quad channel full-pitch phototransistor optocoupler which contains eight light emitting diode optically coupled to four separate phototransistor. It is packaged in a 16-pin DIP package

For both types, it is also available in wide-lead spacing option and lead bend SMD option with input-output isolation voltage at $5000 V_{rms}$. Response time, t_r , is typically $4 \mu s$ and CTR is 20% to 300%.

ACPL-824 pin layout

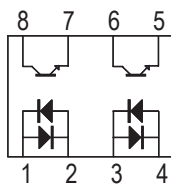

- Pin 1, 3 Anode or Cathode
- Pin 2, 4 Cathode or Anode
- Pin 5, 7 Emitter
- Pin 6, 8 Collector

ACPL-844 pin layout

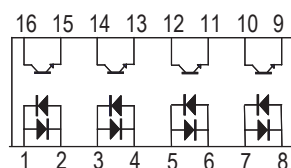

- Pin 1, 3, 5, 7 Anode or Cathode
- Pin 2, 4, 6, 8 Cathode or Anode
- Pin 9, 11, 13, 15 Emitter
- Pin 10, 12, 14, 16 Collector

Features

- Current transfer ratio (CTR: min. 20% at $I_F = \pm 1 mA$, $V_{CE} = 5V$)
- High input-output isolation voltage ($V_{ISO} = 5,000V_{RMS}$)
- Response time (t_r : typ. $4 \mu s$ at $V_{CE} = 2V$, $I_C = 2mA$, $R_L = 100 \Omega$)
- Compact dual-in-line package
- Safety and regulatory approvals
 - CSA
 - UL 1577
 - IEC/EN/DIN EN 60747-5-2
- Options available:
 - Leads with 0.4" (10.16 mm) spacing (W00)
 - Lead bend for surface mounting (300)
 - Tape and reel for SMD (500) – (ACPL-824 only)
 - IEC/EN/DIN EN 60747-5-2 approved (060)
 - Lead-Free (000E)

Applications

- I/O Interface for Programmable controllers, computers
- Sequence controllers
- System appliances, measuring instruments
- Signal transmission between circuits of different potentials and impedances.

Ordering Information

ACPL-8x4 is UL Recognized with 5000 Vrms for 1 minute per UL1577 and is approved under CSA Component Acceptance Notice #5, File CA 88324.

Part number	RoHS Compliant Option		No. of Channels	Surface Mount	Gull Wing	Tape & Reel	IEC/EN/DIN EN 60747-5-2	Quantity
	Rank '0'	Package						
ACPL-824	-000E	300mil DIP-8	Dual					50 pcs per tube
	-300E	300mil DIP-8		x	X			50 pcs per tube
	-500E	300mil DIP-8		X	X	X		1000 pcs per reel
	-060E	300mil DIP-8					X	50 pcs per tube
	-360E	300mil DIP-8		x	x		X	50 pcs per tube
	-560E	300mil DIP-8		x	X	X	X	1000 pcs per reel
	-W00E	400mil DIP-8						50 pcs per tube
	-W60E	400mil DIP-8					X	50 pcs per tube
ACPL-844	-000E	300mil DIP-16	Quad					25 pcs per tube
	-300E	300mil DIP-16		x	X			25 pcs per tube
	-060E	300mil DIP-16					X	25 pcs per tube
	-360E	300mil DIP-16		x	X		X	25 pcs per tube
	-W00E	400mil DIP-16						25 pcs per tube
	-W60E	400mil DIP-16					X	25 pcs per tube

To order, choose a part number from the part number column and combine with the desired option from the option column to form an order entry.

Example 1:

ACPL-824-360E to order product of 300mil DIP-8 Dual Channel AC Gull Wing Surface Mount package in Tube packaging with 20%<CTR<300%, IEC/EN/DIN EN 60767-5-2 Safety Approval and RoHS compliant.

Example 2:

ACPL-844-W00E to order product of 400mil DIP-16 Quad Channel AC package in Tube packaging with 20%<CTR<300% and RoHS compliant.

Option datasheets are available. Contact your Avago sales representative or authorized distributor for information.

Package Outline Drawings

ACPL-824 Package Outline

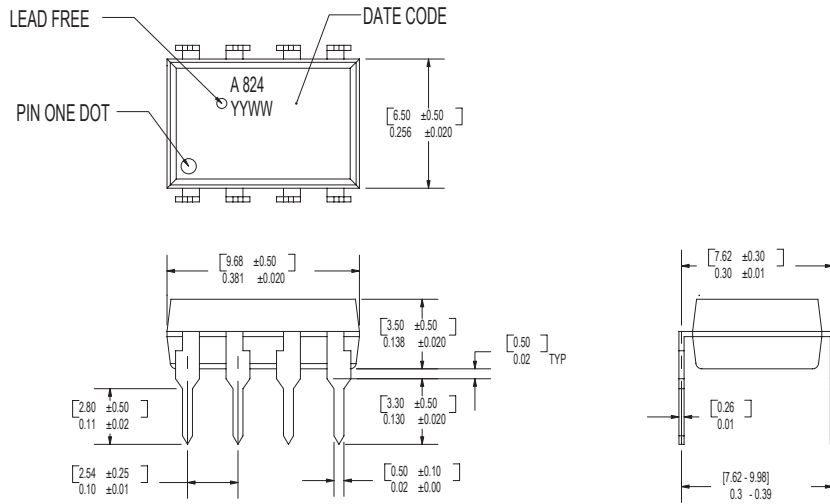

DIMENSIONS IN [MILLIMETERS] AND INCHES

ACPL-824 Package Outline – Option 060

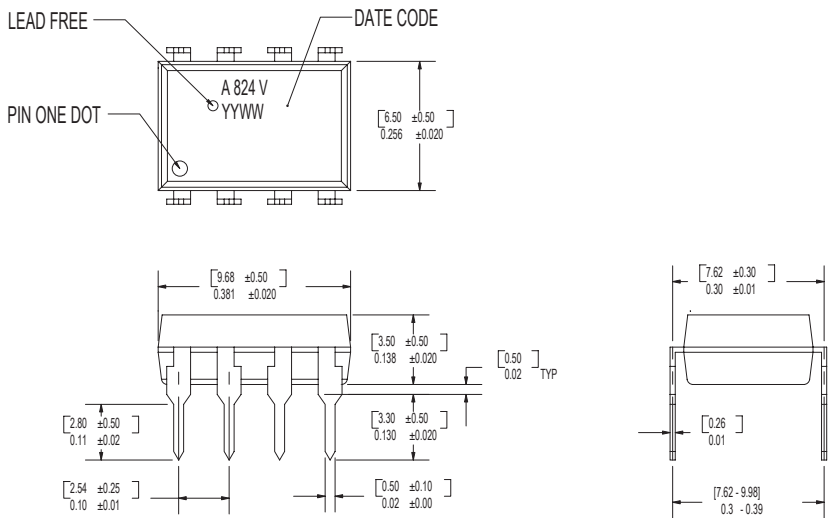

DIMENSIONS IN [MILLIMETERS] AND INCHES

ACPL-824 Package Outline – Option W00

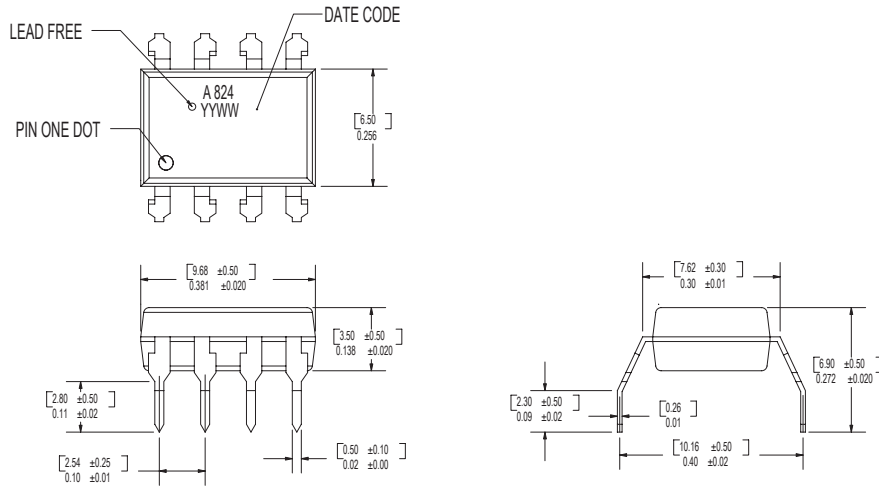

DIMENSIONS IN [MILLIMETERS] AND INCHES

ACPL-824 Package Outline – Option 300

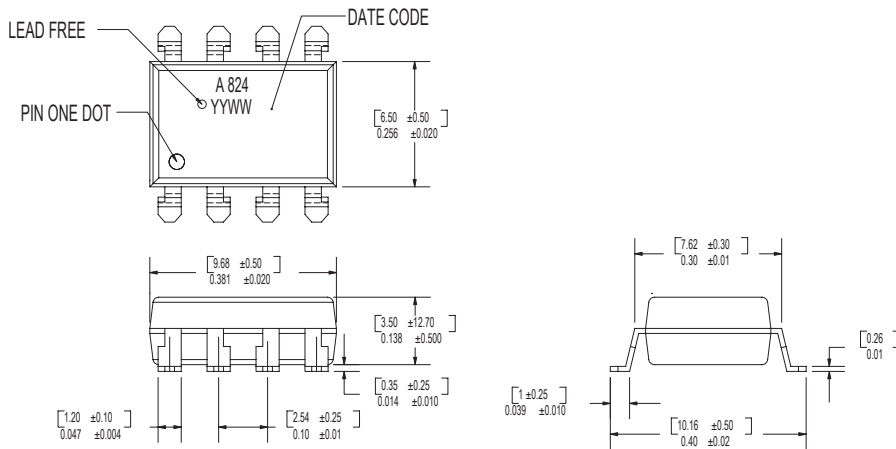

DIMENSIONS IN [MILLIMETERS] AND INCHES

ACPL-844 Package Outline

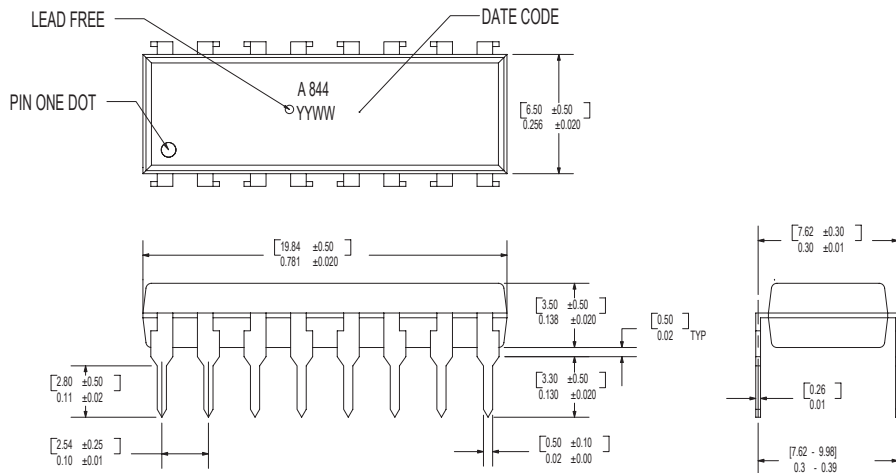

DIMENSIONS IN [MILLIMETERS] AND INCHES

ACPL-844 Package Outline - Option 060

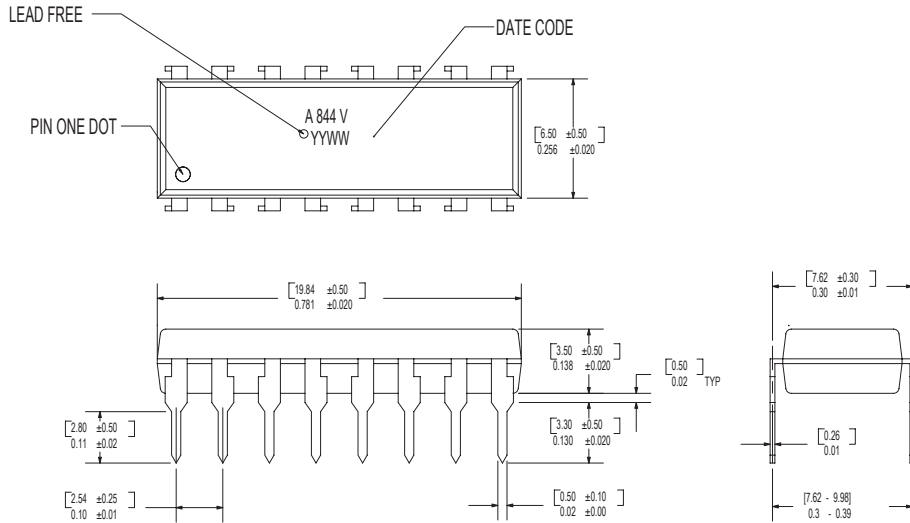

DIMENSIONS IN [MILLIMETERS] AND INCHES

ACPL-844 Package Outline - Option W00

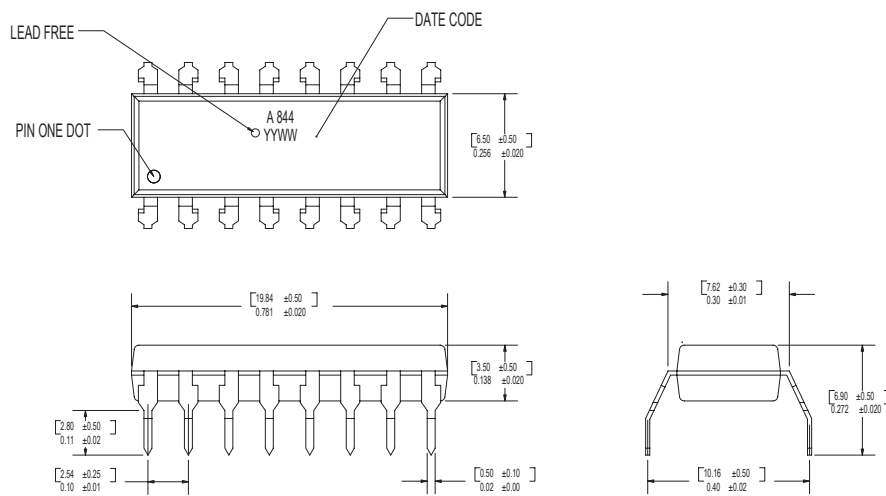

DIMENSIONS IN [MILLIMETERS] AND INCHES

ACPL-844 Package Outline - Option 300

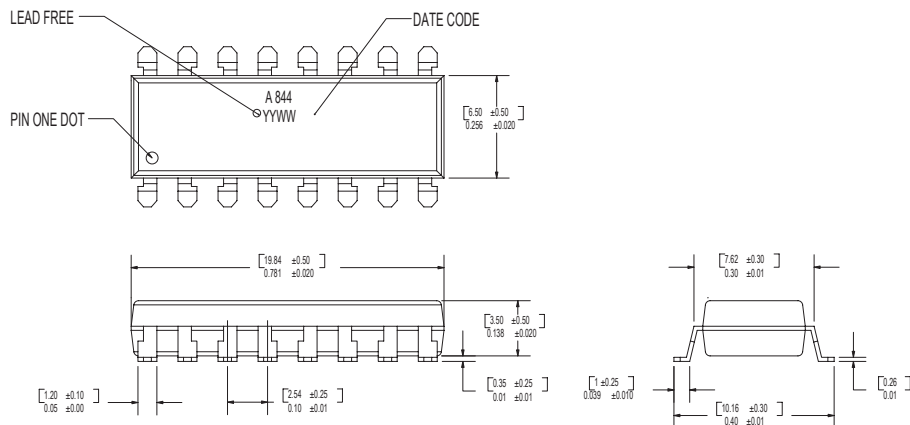

DIMENSIONS IN [MILLIMETERS] AND INCHES

Solder Reflow Temperature Profile

1. One-time soldering reflow is recommended within the condition of temperature and time profile shown at right.
2. When using another soldering method such as infrared ray lamp, the temperature may rise partially in the mold of the device. Keep the temperature on the package of the device within the condition of (1) above.

Note: Non-halide flux should be used

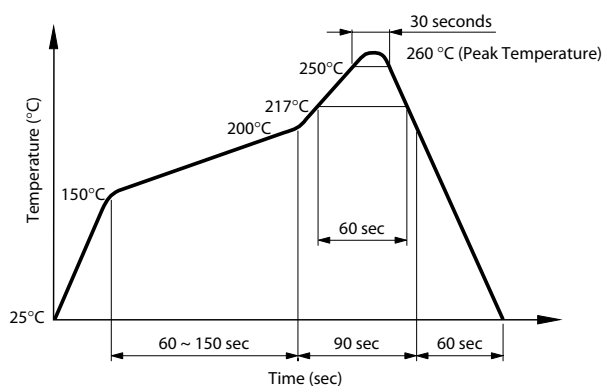

Absolute Maximum Ratings

Parameter	Symbol	Min.	Max.	Units	Note
Storage Temperature	T_S	-55	125	°C	
Operating Temperature	T_A	-30	100	°C	
Average Forward Current	$I_{F(AVG)}$	-	±50	mA	
Input Power Dissipation	P_I	-	70	mW	
Collector Current	I_C	-	50	mA	
Collector-Emitter Voltage	V_{CEO}	-	70	V	
Emitter-Collector Voltage	V_{ECO}	-	6	V	
Isolation Voltage (AC for 1min, R.H. 40~60%)	V_{ISO}	-	5000	V_{RMS}	
Collector Power Dissipation	P_C	-	150	mW	
Total Power Dissipation	P_{TOT}	-	200	mW	
Lead Solder Temperature			260°C for 10 sec., 1.6 mm below seating plane		

Electrical Specifications (DC)

Over recommended operating conditions unless otherwise specified.

Parameter	Symbol	Min.	Typ.	Max.	Units	Test Conditions	Note
Forward Voltage	V_F	-	1.2	1.4	V	$I_F = \pm 20\text{mA}$	
Terminal Capacitance	C_t		50	250	pF	$V = 0, f = 1\text{KHz}$	
Collector Dark Current	I_{CEO}		-	100	nA	$V_{CE} = 20\text{V}, I_F = 0\text{mA}$	
Collector-Emitter Breakdown Voltage	$B_{V_{CEO}}$	70	-	-	V	$I_C = 0.1\text{mA}, I_F = 0\text{mA}$	
Emitter-Collector Breakdown Voltage	$B_{V_{ECO}}$	6	-	-	V	$I_E = 10\ \mu\text{A}, I_F = 0\text{mA}$	
Collector Current	I_C	0.2	-	3	mA	$I_F = \pm 1\text{mA}, V_{CE} = 5\text{V}$	$CTR = (I_C/I_F) * 100\%$
Current Transfer Ratio	CTR	20	-	300	%		
Collector-Emitter Saturation Voltage	$V_{CE(sat)}$	-	0.1	0.2	V	$I_F = \pm 20\text{mA}, I_C = 1\text{mA}$	
Isolation Resistance	R_{ISO}	5×10^{10}	1×10^{11}	-	Ω	DC500V, R.H. 40~60%	
Floating Capacitance	C_F	-	0.6	1	pF	$V = 0, f = 1\text{MHz}$	
Cut-off Frequency (-3dB)	F_C	15	80	-	KHz	$V_{CE} = 5\text{V}, I_C = 2\text{mA}, R_L = 100\Omega$	See fig 13
Response Time (Rise)	t_r	-	4	18	μs	$V_{CE} = 2\text{V}, I_C = 2\text{mA}, R_L = 100\Omega$	See fig 12
Response Time (Fall)	t_f	-	3	18	μs		

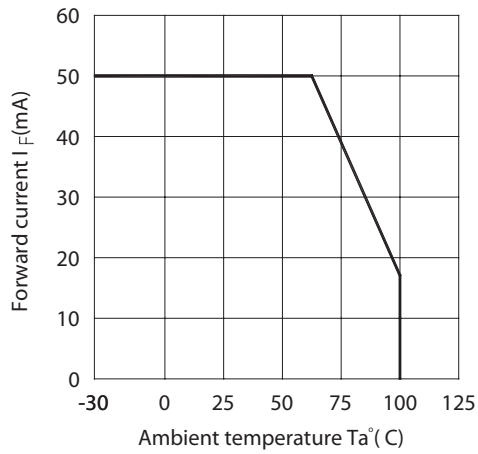

Figure 1. Forward Current vs. Ambient Temperature.

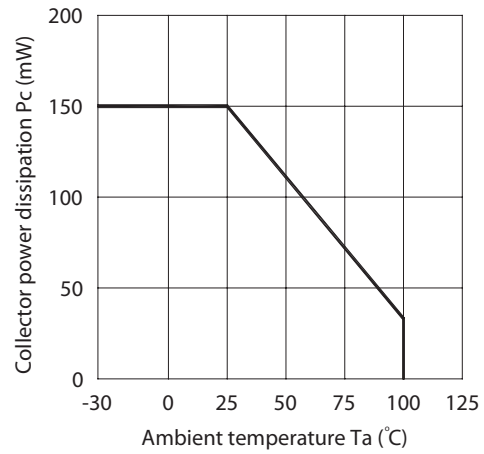

Figure 2. Collector Power Dissipation vs. Ambient Temperature

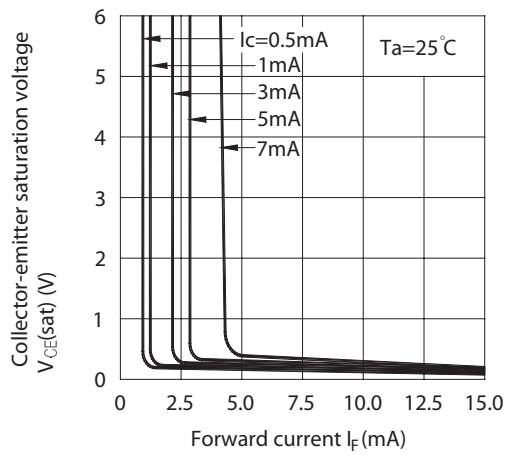

Figure 3. Collector-emitter Saturation Voltage vs. Forward Current

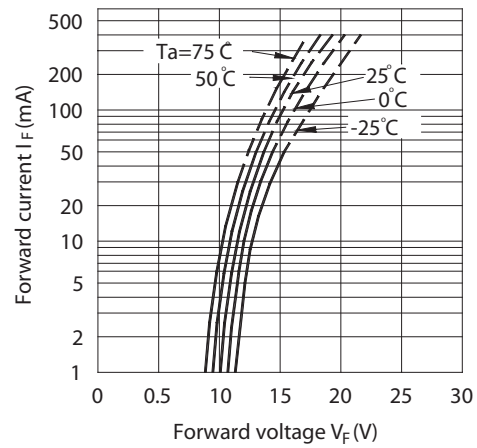

Figure 4. Forward Current vs. Forward Voltage

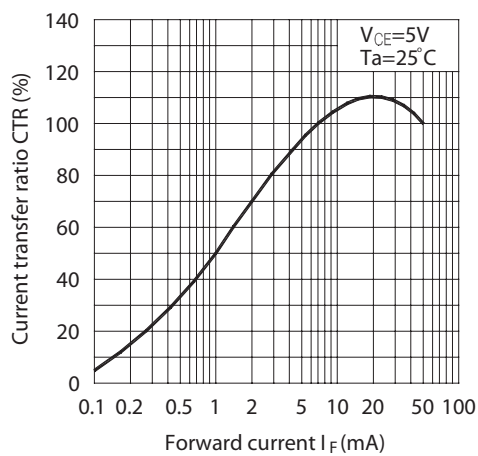

Figure 5. Current Transfer Ratio vs. Forward Current

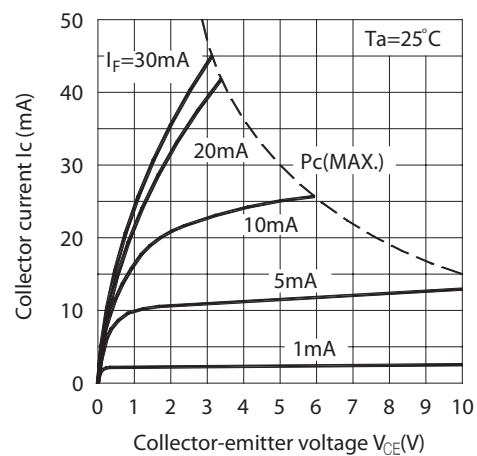

Figure 6. Collector Current vs. Collector-emitter Voltage.

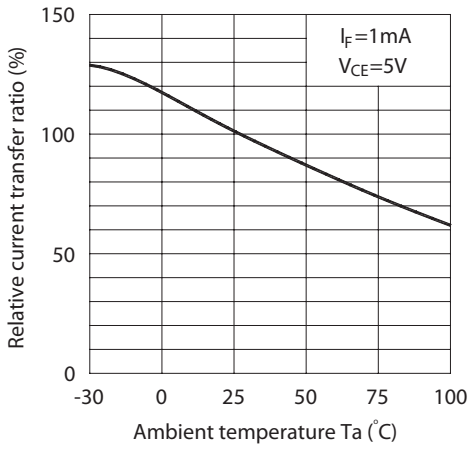

Figure 7. Relative Current Transfer Ratio vs. Ambient Temperature

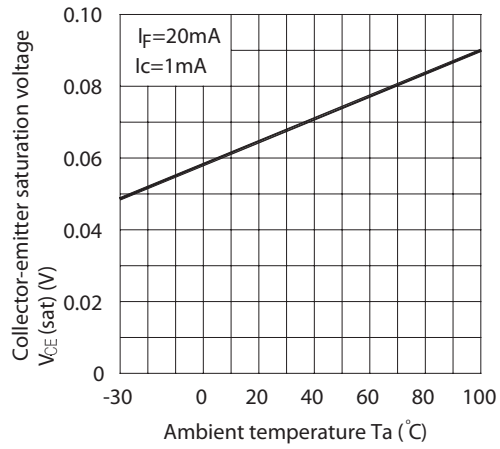

Figure 8. Collector-emitter Saturation Voltage vs. Ambient Temperature

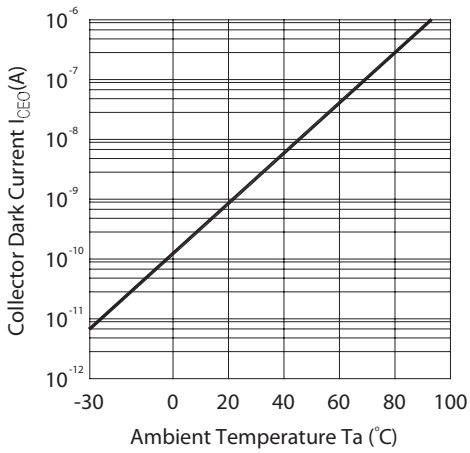

Figure 9. Collector Dark Current vs. Ambient Temperature

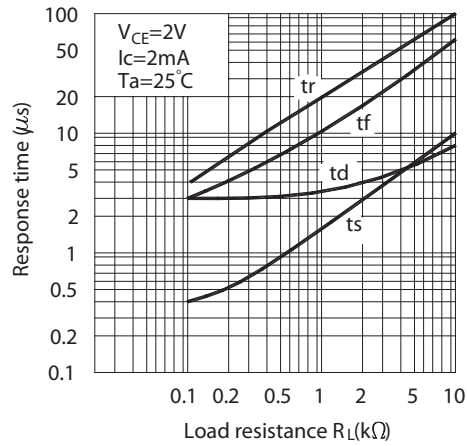

Figure 10. Response Time vs. Load Resistance

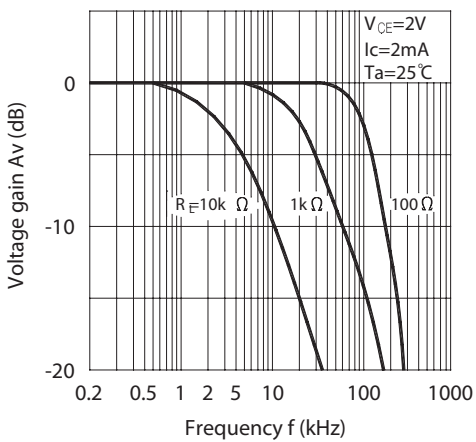

Figure 11. Frequency Response

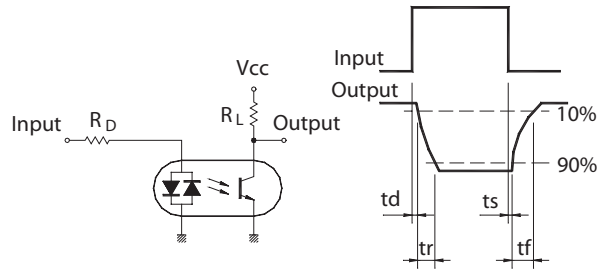

Figure 12. Test Circuit for Response Time

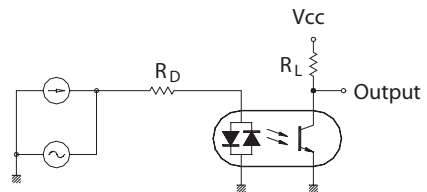

Figure 13. Test Circuit for Frequency Response

For product information and a complete list of distributors, please go to our web site: www.avagotech.com

Avago, Avago Technologies, and the A logo are trademarks of Avago Technologies Limited. in the United States and other countries.
Data subject to change. Copyright © 2006 Avago Technologies Limited. All rights reserved.
AV01-0475EN - May 22, 2007

