

UNCONTROLLED DOCUMENT

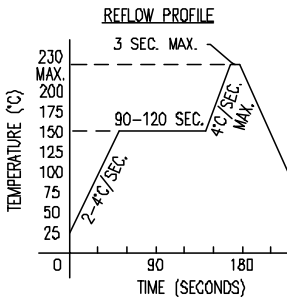

RECOMMENDED SOLDER PAD LAYOUT

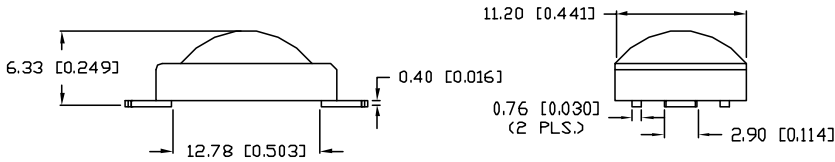
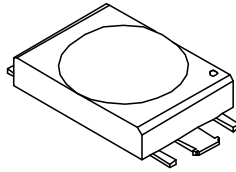
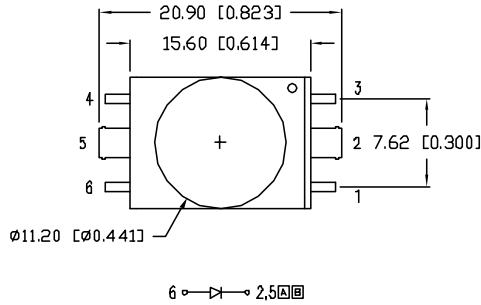
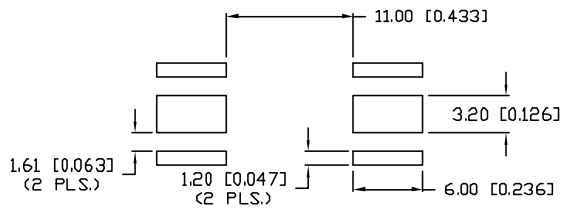

\*UNLESS OTHERWISE SPECIFIED TOLERANCES PER DECIMAL PRECISION ARE: X=±1 (±0.038), XX=±0.5 (±0.020), XXX=±0.25 (±0.010), XXXX=±0.127 (±0.005). LEAD SIZE=±0.05 (±0.002), LEAD LENGTH=±0.75 (±0.030). MIN= <sup>+0.00</sup>/<sub>-0.00</sub> DECIMAL PRECISION, MAX= <sup>+0.00</sup>/<sub>-0.00</sub> DECIMAL PRECISION

PART NUMBER		REV.
SSP-LX6144D6UC		B
REV.	E.C.N. NUMBER AND REVISION COMMENTS	DATE
A	E.C.N. #11073.	12.31.03
B	E.C.N. #11102.	2.27.04

ELECTRO-OPTICAL CHARACTERISTICS T <sub>A</sub> =25°C I <sub>f</sub> =120mA					
PARAMETER	MIN	TYP	MAX	UNITS	TEST COND
PEAK WAVELENGTH		626		nm	
FORWARD VOLTAGE		2.4	2.8	V <sub>f</sub>	
REVERSE VOLTAGE	5.0			V <sub>r</sub>	I <sub>f</sub> =100µA
AXIAL INTENSITY		3.2		cd	I <sub>f</sub> =120mA
TOTAL FLUX		2.5		Lm	I <sub>f</sub> =120mA
VIEWING ANGLE		100		2x theta	
EMITTED COLOR:	RED				
EPOXY LENS FINISH:	WATER CLEAR				

LIMITS OF SAFE OPERATION AT 25°C		
PARAMETER	MAX	UNITS
PEAK FORWARD CURRENT*	250	mA
STEADY CURRENT	120	mA
POWER DISSIPATION	320	mW
DERATE FROM 25°C	-1.2	mW/°C
OPERATING TEMP.	-20 TO +80	°C
STORAGE TEMP.	-35 TO +85	°C

\* t < 10µS

NOTES:  
1. PARTS ARE PACKAGED IN ANTI-STATIC TUBES.

UNCONTROLLED DOCUMENT

REV.	PART NUMBER
B	SSP-LX6144D6UC
LOW PROFILE SMT, 100° VIEWING LuxLED,™ 626nm RED, WATER CLEAR LENS.	

**CONFIDENTIAL INFORMATION**  
THE INFORMATION CONTAINED IN THIS DOCUMENT IS THE PROPERTY OF SUNBRITE LEDS. EXCEPT AS SPECIFICALLY AUTHORIZED IN WRITING BY SUNBRITE LEDS, THE HOLDER OF THIS DOCUMENT SHALL KEEP ALL INFORMATION CONTAINED HEREIN CONFIDENTIAL AND SHALL PROTECT SAME IN WHOLE OR IN PART FROM DISCLOSURE AND DISSEMINATION TO ALL THIRD PARTIES.

**RELIABILITY NOTE**  
OUR MANY YEARS OF EXPERIENCE DATA ACCUMULATION INDICATE THAT SOLDER HEAT IS A MAJOR CAUSE OF EARLY AND FUTURE FAILURE. PLEASE PAY ATTENTION TO YOUR SOLDERING PROCESS.



286 E. HELEN ROAD PALATINE, IL 60067-6976 PHONE: +1.847.348.3116 FAX: +1.847.359.2867 WEB: www.sunbriteleds.com	
DRAWN: BC	CHECKED:
APPROVED:	DATE: 7.18.03 PAGE: 1 OF 1