

## PRELIMINARY SPEC



**ATTENTION**  
OBSERVE PRECAUTIONS  
FOR HANDLING  
ELECTROSTATIC  
DISCHARGE  
SENSITIVE

Part Number: AAD1-9090BRGC-01/3

Blue  
Reddish-Orange  
Green



## Features

- Super high flux output and high luminance.
- Designed for high current operation.
- Low thermal resistance.
- Low voltage DC operated.
- Superior ESD protection.
- Not reflow compatible.
- The component is internally protected with silicone gel.
- RoHS compliant.

## Application Note

Static electricity and surge damage the LEDs.  
It is recommended to use a wrist band or anti-electrostatic glove when handling the LEDs.  
All devices, equipment and machinery must be electrically grounded.

## Applications

- traffic signaling.
- backlighting (illuminated advertising, general lighting).
- interior and exterior automotive lighting.
- substitution of micro incandescent lamps.
- portable light source (e.g. bicycle flashlight).
- signal and symbol luminaire for orientation.
- marker lights (e.g. steps, exit ways, etc).
- decorative and entertainment lighting.
- indoor and outdoor commercial and residential architectural lighting.

## Package Dimensions

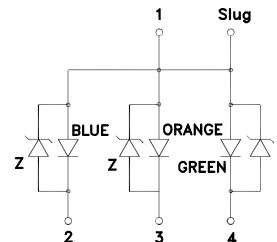
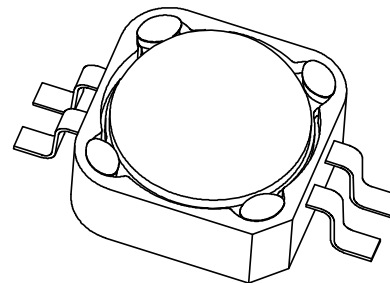
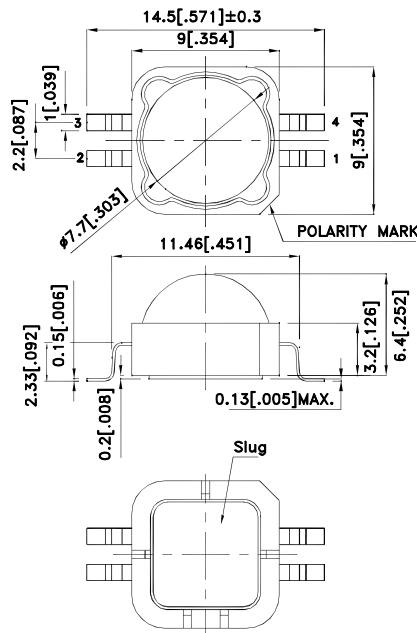

### Notes:

1. All dimensions are in millimeters (inches).
2. Tolerance is ±0.25(0.01") unless otherwise noted.
3. Specifications are subject to change without notice.
4. The device has a single mounting surface. The device must be mounted according to the specifications.



## Selection Guide

Part No.	Dice	Lens Type	luminous Intensity [2] lv(cd)@ 350mA		$\Phi_v$ (lm) [2] @ 350mA		Viewing Angle [1]
			Min.	Typ.	Min.	Typ.	
AAD1-9090BRGC-01/3	BLUE (AlGaInN)	WATER CLEAR	2.5	3.5	15	20	135°
	Reddish-Orange (AlGaInP)		6.7	8	25	30	
	Green (AlGaInN)		10	16	32	50	

Notes:

1.  $\theta_{1/2}$  is the angle from optical centerline where the luminous intensity is 1/2 the optical centerline value.
2. Luminous intensity / luminous Flux: +/-15%.

## Absolute Maximum Ratings at $T_A=25^\circ\text{C}$

Parameter	Symbol	Device	Value	Unit
Power dissipation	$P_t$	Blue	1.25	W
		Reddish-Orange	1.05	
		Green	1.33	
Junction temperature	$T_J$	Blue	110	°C
		Reddish-Orange	110	
		Green	110	
Operating Temperature	Top	Blue	-40 To +100	°C
		Reddish-Orange		
		Green		
Storage Temperature	$T_{stg}$	Blue	-40 To +100	°C
		Reddish-Orange		
		Green		
DC Forward Current [1]	$I_F$	Blue	350	mA
		Reddish-Orange	350	
		Green	350	
Peak Forward Current [2]	$I_{FM}$	Blue	500	mA
		Reddish-Orange	500	
		Green	500	
Thermal resistance [1]	$R_{th j-slug}$	Blue	9	°C/W
		Reddish-Orange	12	
		Green	9	
Electrostatic Discharge Threshold (HBM)		Blue	8000	V
		Reddish-Orange		
		Green		
Iron Soldering [3]		Blue	350°C For 3 Seconds	
		Reddish-Orange		
		Green		

Notes:

1. Results from mounting on MCPCB.
2. 1/10 Duty Cycle, 0.1ms Pulse Width.
3. 1.29mm distance from solder joint to package.

## Electrical / Optical Characteristics at T<sub>A</sub>=25°C

Parameter	Symbol	Device	Value			Unit
			Min.	Typ.	Max.	
Wavelength at peak emission I <sub>F</sub> =350mA	λ <sub>peak</sub>	Blue		452		nm
		Reddish-Orange		640		
		Green		520		
Dominant Wavelength I <sub>F</sub> =350mA	λ <sub>dom</sub> [1]	Blue		458		nm
		Reddish-Orange		625		
		Green		530		
Spectral bandwidth at 50%Φ <sub>REL MAX</sub> I <sub>F</sub> =350mA	Δλ	Blue		20		nm
		Reddish-Orange		30		
		Green		35		
Forward Voltage I <sub>F</sub> =350mA	V <sub>F</sub> [2]	Blue	2.8	3.2	3.6	V
		Reddish-Orange	2.0	2.5	3.0	
		Green	2.7	3.3	3.8	
Temperature coefficient of λ <sub>peak</sub> I <sub>F</sub> =350mA, -10°C ≤ T ≤ 100°C	TC <sub>λ<sub>peak</sub></sub>	Blue		0.2		nm/°C
		Reddish-Orange		0.12		
		Green		0.16		
Temperature coefficient of λ <sub>dom</sub> I <sub>F</sub> =350mA, -10°C ≤ T ≤ 100°C	TC <sub>λ<sub>dom</sub></sub>	Blue		0.1		nm/°C
		Reddish-Orange		0.05		
		Green		0.14		
Temperature coefficient of V <sub>F</sub> I <sub>F</sub> =350mA, -10°C ≤ T ≤ 100°C	TC <sub>V</sub>	Blue		-3.2		mV/°C
		Reddish-Orange		-2.6		
		Green		-2.26		

Notes:

1. Wavelength: +/-1nm.
2. Forward Voltage: +/-0.1V.

# Kingbright

## AAD1-9090BRGC-01/3 Blue

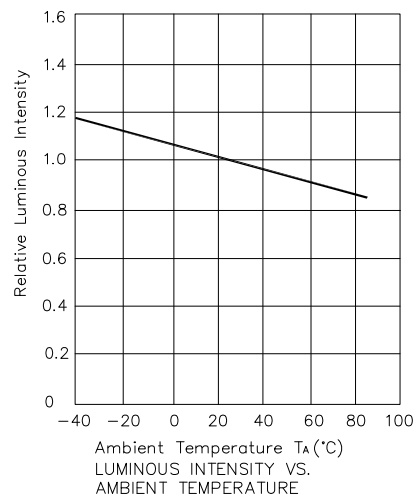
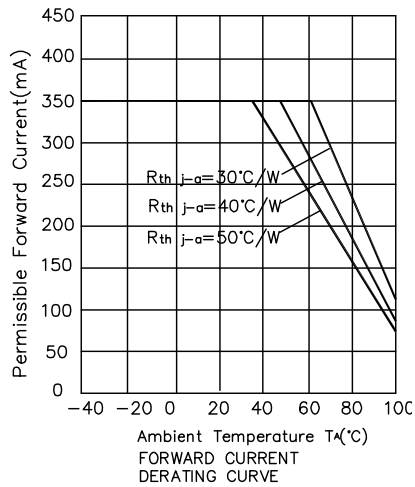
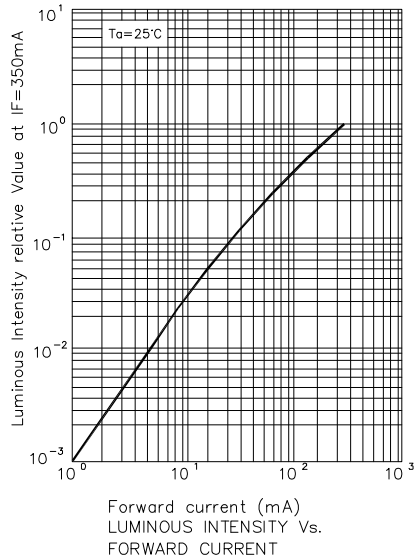
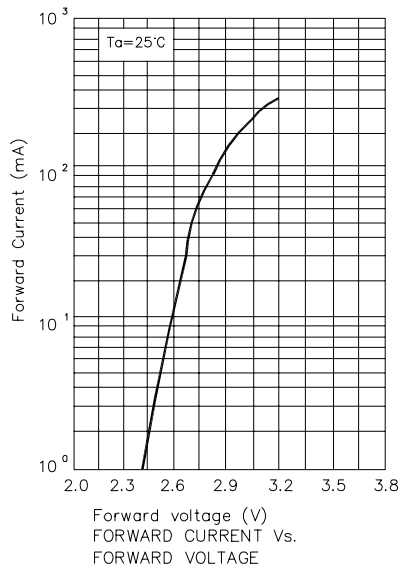
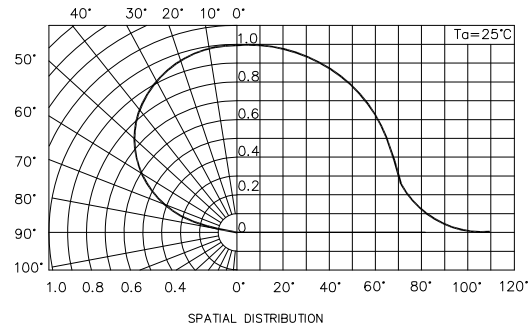
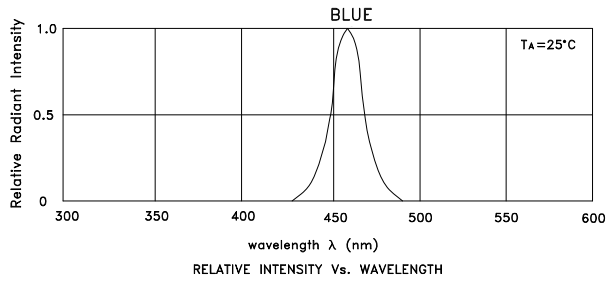

# Kingbright

## Reddish-Orange

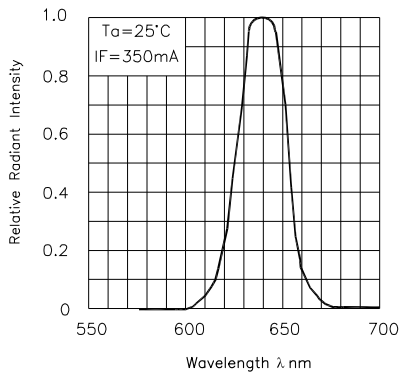

RELATIVE INTENSITY Vs. WAVELENGTH

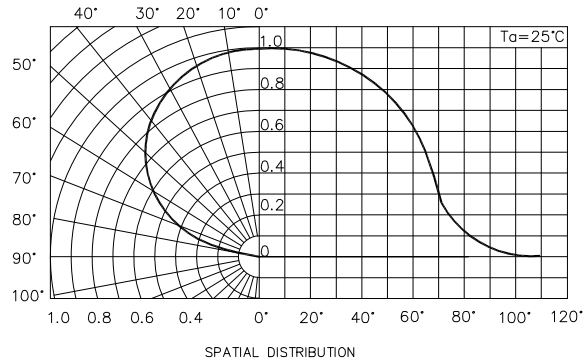

SPATIAL DISTRIBUTION

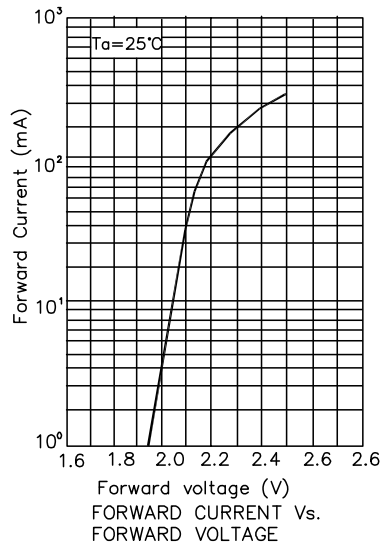

FORWARD CURRENT Vs. FORWARD VOLTAGE

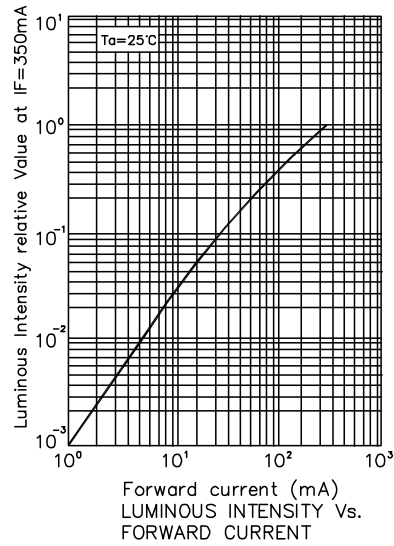

LUMINOUS INTENSITY Vs. FORWARD CURRENT

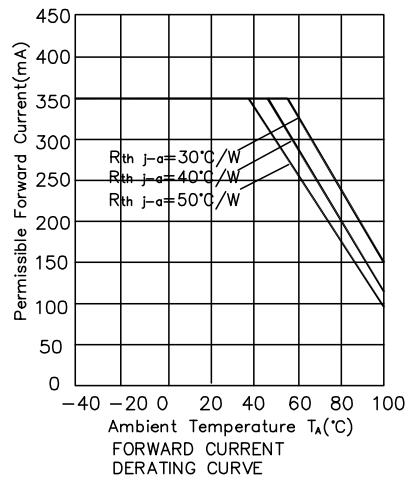

FORWARD CURRENT DERATING CURVE

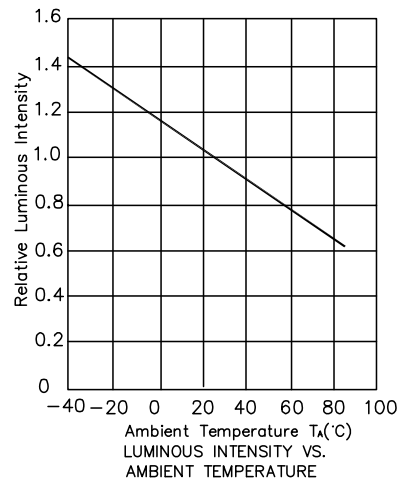

LUMINOUS INTENSITY Vs. AMBIENT TEMPERATURE

# Kingbright

## Green

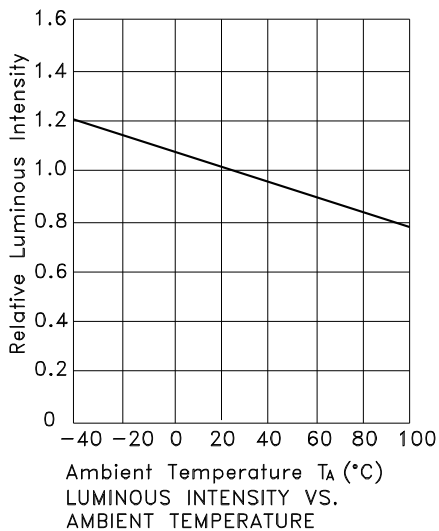
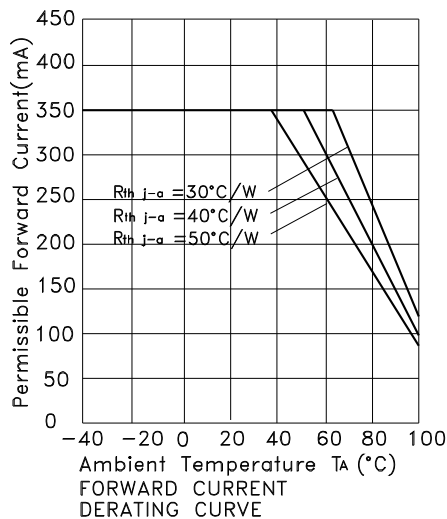
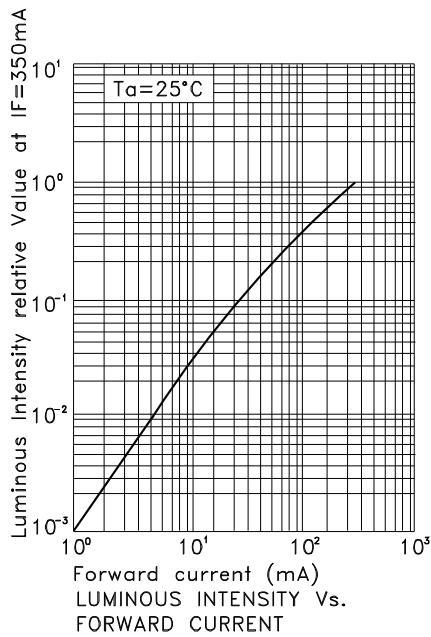
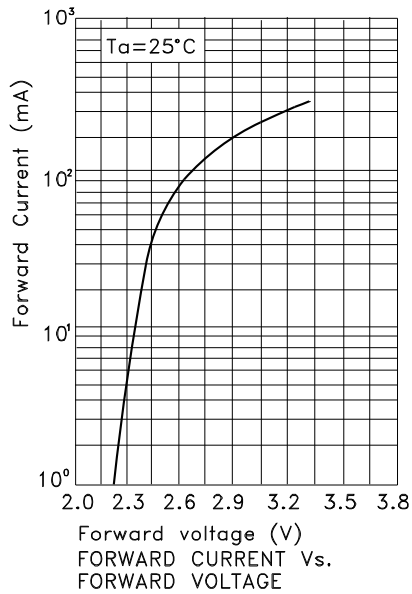
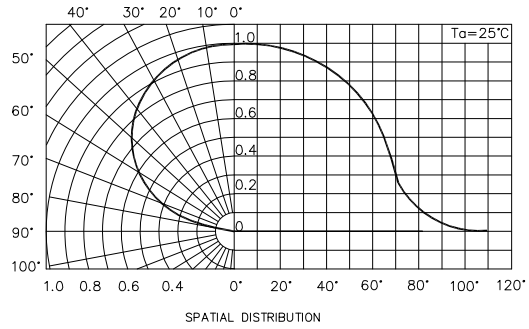
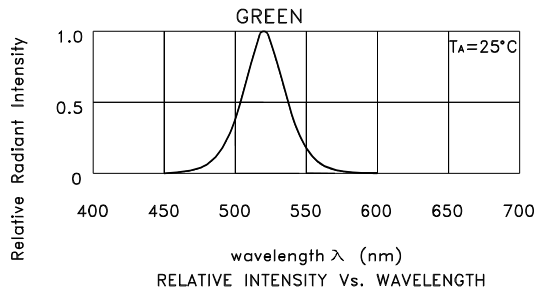

**AAD1-9090BRGC-01/3**  
**Recommended Soldering Pattern**  
 (Units : mm; Tolerance:  $\pm 0.1$ )

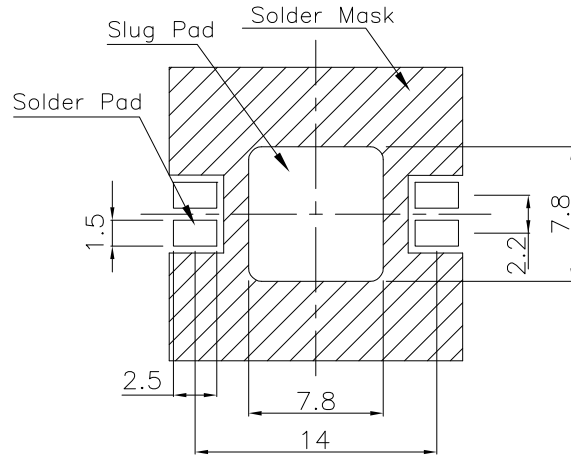

**Tape Specifications**  
 (Units : mm)

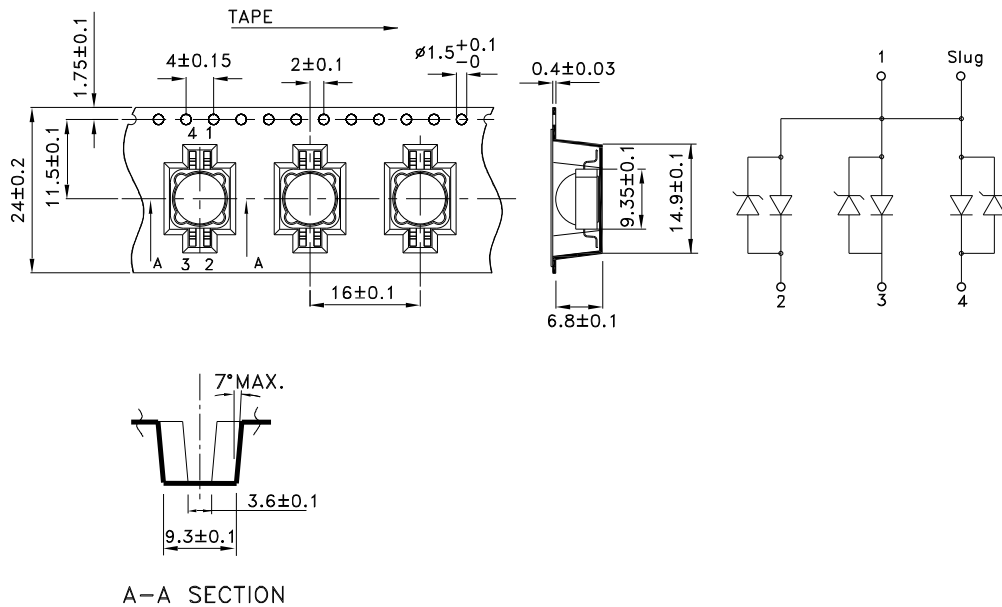

AAD1-9090BRGC-01/3

## Recommended Solder Steps

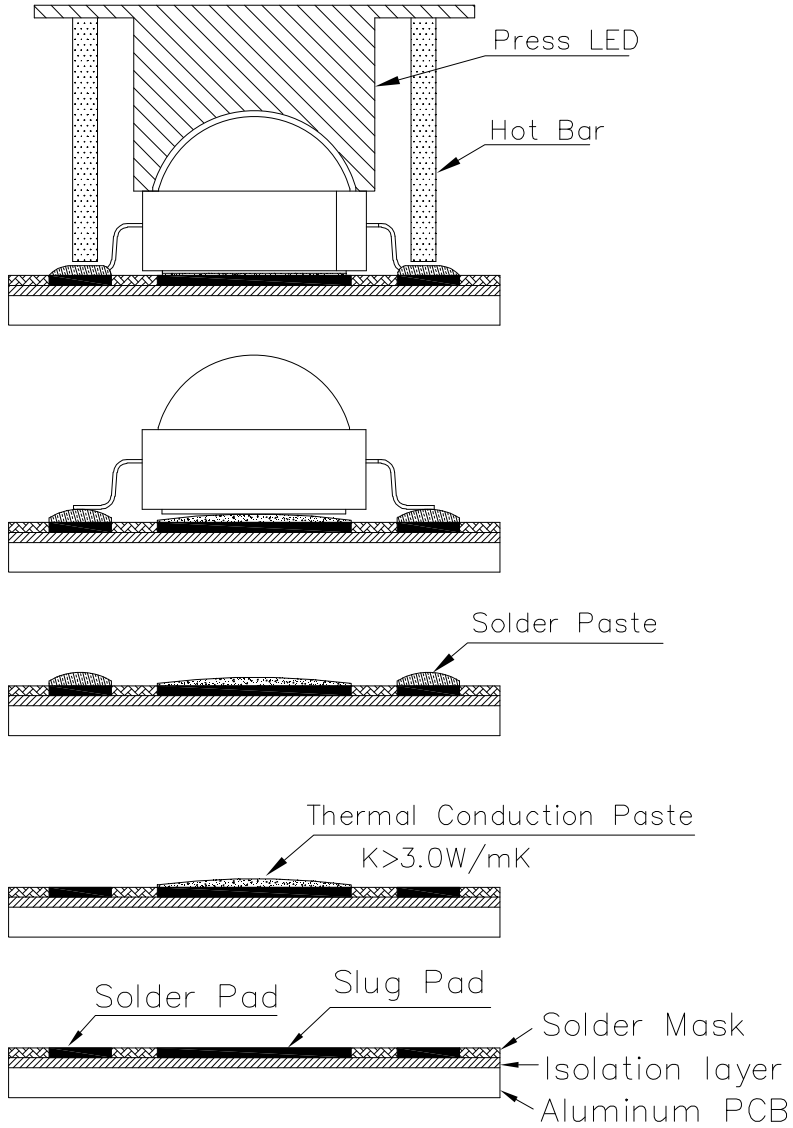



**PACKING & LABEL SPECIFICATIONS**

**AAD1-9090BRGC-01/3**

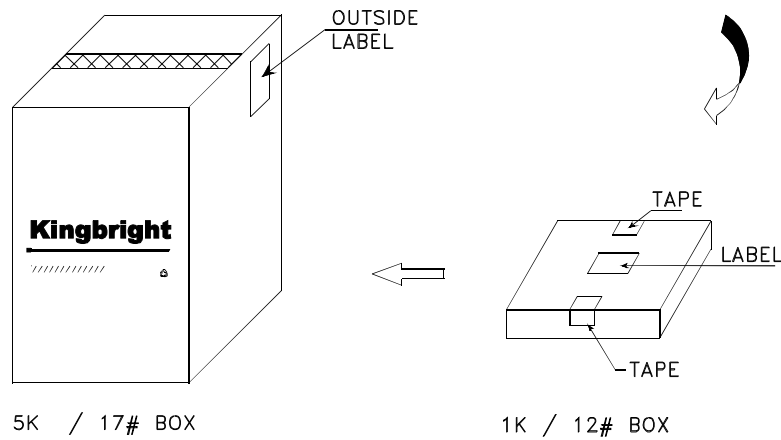
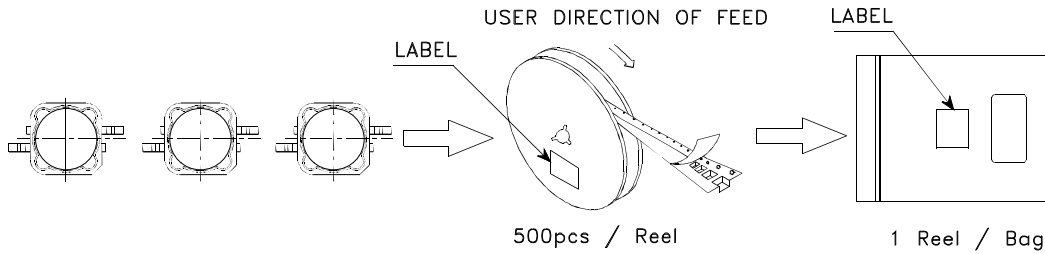

<h1>Kingbright</h1>	
P/NO: AAD1-9090xxx	
QTY: 500 pcs	Q.C. <span style="border: 1px solid black; border-radius: 50%; padding: 2px;">Q C XX XX XXXX PASSED</span>
S/N: XXXX	
CODE: XXX	
LOT NO:	
 XXXXXXXXXXXXXXXXXXXXXXXXXXXX	
RoHS Compliant	