



# Kingbright

## Handling Precautions

Compare to epoxy encapsulant that is hard and brittle, silicone is softer and flexible. Although its characteristic significantly reduces thermal stress, it is more susceptible to damage by external mechanical force.

As a result, special handling precautions need to be observed during assembly using silicone encapsulated LED products. Failure to comply might lead to damage and premature failure of the LED.

1. Handle the component along the side surfaces by using forceps or appropriate tools.

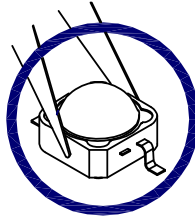

2. Do not directly touch or handle the silicone lens surface. It may damage the internal circuitry.



3. Do not stack together assembled PCBs containing exposed LEDs. Impact may scratch the silicone lens or damage the internal circuitry.

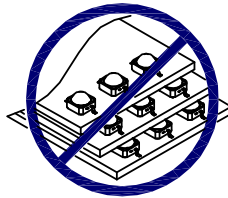

- 4.1. The outer diameter of the SMD pickup nozzle should not exceed the size of the LED to prevent air leaks. The inner diameter of the nozzle should be as large as possible.
- 4.2. A pliable material is suggested for the nozzle tip to avoid scratching or damaging the LED surface during pickup.
- 4.3. The dimensions of the component must be accurately programmed in the pick-and-place machine to insure precise pickup and avoid damage during production.

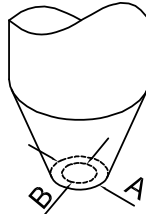

5. As silicone encapsulation is permeable to gases, some corrosive substances such as  $H_2S$  might corrode silver plating of leadframe. Special care should be taken if an LED with silicone encapsulation is to be used near such substances.

## Selection Guide

Part No.	Dice	Lens Type	luminous Intensity Iv (cd)@ 500 mA [2]		Φv (lm) @ 500 mA [2]		Viewing Angle [1]
			Min.	Typ.	Min.	Typ.	2θ1/2
AAD1-9090SE9ZC/2	REDDISH-ORANGE (AlGaInP)	Water Clear	12	20	35	50	100°

Notes:

1. θ1/2 is the angle from optical centerline where the luminous intensity is 1/2 of the optical peak value.
2. Luminous intensity/ luminous Flux: +/-15%.

## Absolute Maximum Ratings at TA=25°C

Parameter	Symbol	Value	Unit
Power dissipation	P <sub>D</sub>	1.65	W
Junction temperature	T <sub>J</sub>	110	°C
Reverse Voltage	V <sub>R</sub>	5	V
Operating Temperature	T <sub>op</sub>	-40 To +100	°C
Storage Temperature	T <sub>stg</sub>	-40 To +100	°C
DC Forward Current [1]	I <sub>F</sub>	500	mA
Peak Forward Current [2]	I <sub>FM</sub>	700	mA
Thermal resistance [1]	R <sub>th j-slug</sub>	12	°C/W
Electrostatic Discharge Threshold (HBM)		8000	V
Iron Soldering [3]		350°C For 3 Seconds	

Notes:

1. Results from mounting on MCPCB.
2. 1/10 Duty Cycle, 0.1ms Pulse Width.
3. 1.29mm distance from solder joint to package.

## Electrical / Optical Characteristics at TA=25°C

Parameter	Symbol	Value	Unit
Wavelength at peak emission I <sub>F</sub> =500mA [Typ.]	λ <sub>peak</sub>	635	nm
Dominant Wavelength I <sub>F</sub> =500mA [Typ.]	λ <sub>dom</sub> [1]	623	nm
Spectral bandwidth at 50%Φ <sub>REL MAX</sub> I <sub>F</sub> =500mA [Typ.]	Δλ	22	nm
Allowable Reverse Current [Max.]	I <sub>R</sub>	85	mA
Forward Voltage I <sub>F</sub> =500mA [Min.]	V <sub>F</sub> [2]	-	V
Forward Voltage I <sub>F</sub> =500mA [Typ.]		2.7	
Forward Voltage I <sub>F</sub> =500mA [Max.]		3.3	
Temperature coefficient of λ <sub>peak</sub> I <sub>F</sub> =500mA, -10°C ≤ T ≤ 100°C [Typ.]	TC <sub>λ,peak</sub>	0.08	nm/°C
Temperature coefficient of λ <sub>dom</sub> I <sub>F</sub> =500mA, -10°C ≤ T ≤ 100°C [Typ.]	TC <sub>λ,dom</sub>	0.03	nm/°C
Temperature coefficient of V <sub>F</sub> I <sub>F</sub> =500mA, -10°C ≤ T ≤ 100°C [Typ.]	TC <sub>V</sub>	-2.8	mV/°C

Notes:

1. Wavelength: +/-1nm.
2. Forward Voltage: +/-0.1V.

# Kingbright

## AAD1-9090SE9ZC/2

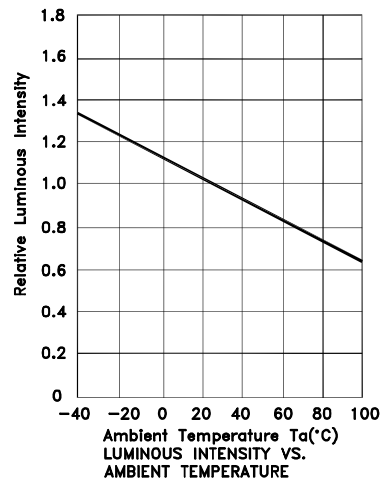
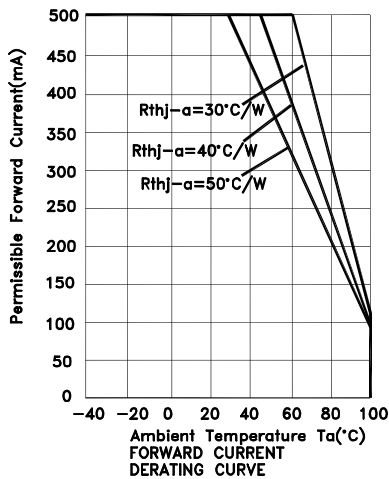
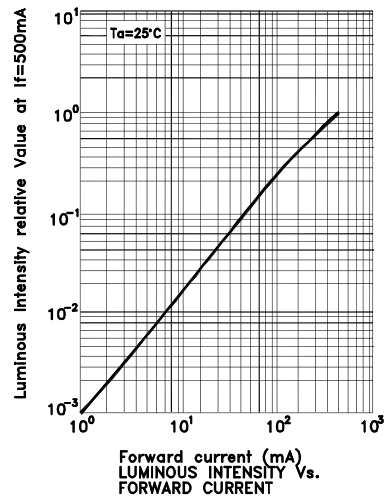
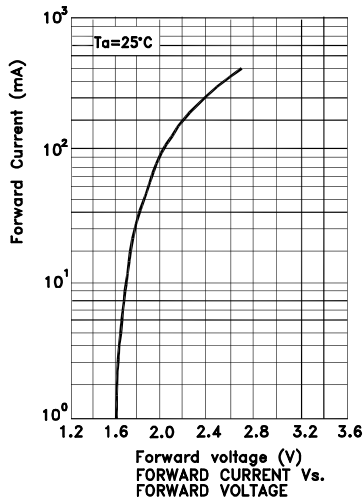
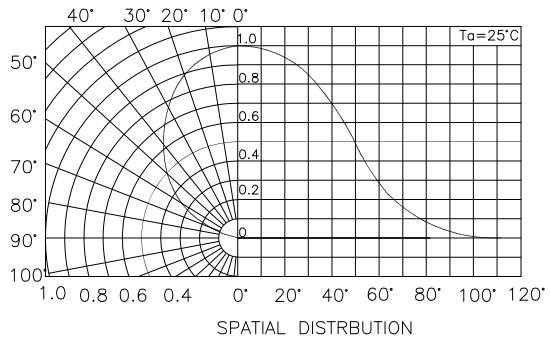
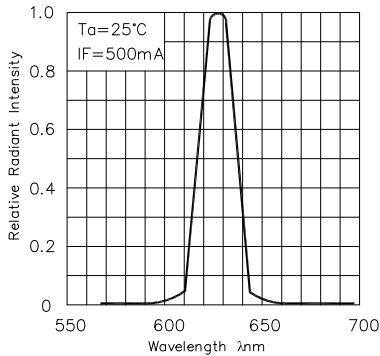



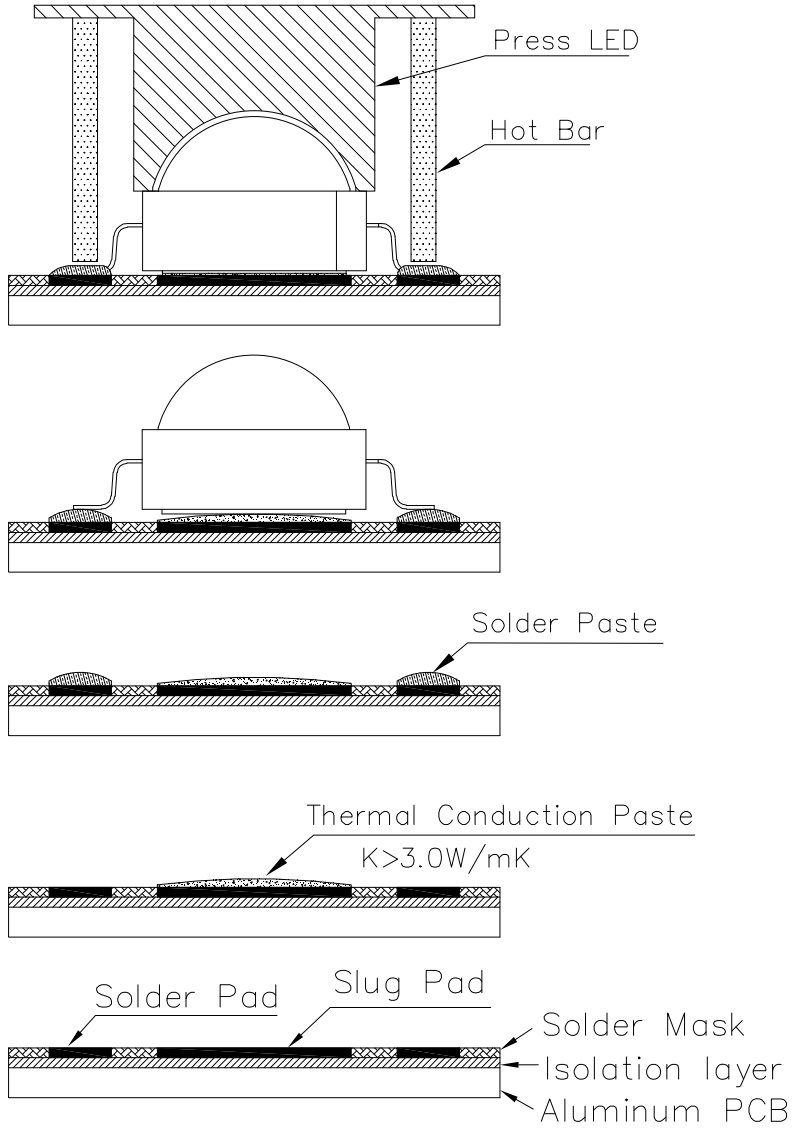

**AAD1-9090SE9ZC/2**  
**Recommended Solder Steps**

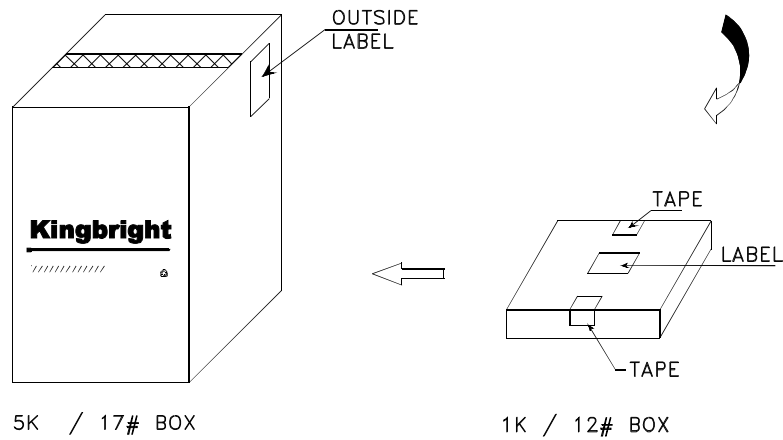
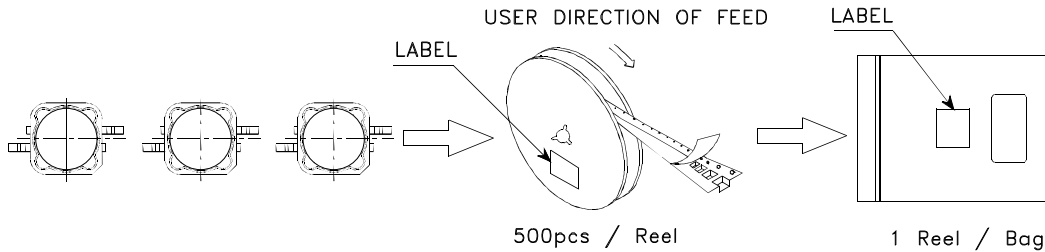

**PACKING & LABEL SPECIFICATIONS**

**AAD1-9090SE9ZC/2**



<h1>Kingbright</h1>	
P/NO: AAD1-9090xxx	
QTY: 500 pcs	Q.C. <span style="border: 1px solid black; border-radius: 50%; padding: 2px;">Q C XX XX XXXX PASSED</span>
S/N: XXXX	
CODE: XXX	
LOT NO:	
 XXXXXXXXXXXXXXXXXXXXXXXXXXXX	
RoHS Compliant	