

Preliminary
August 19, 2009



Cree® XLamp® XP-E Royal Blue LEDs

Data Sheet

The XLamp color XP-E LED combines the proven performance and reliability of the XLamp XR color LED in a package with 80% smaller footprint. The XLamp XP-E LED continues Cree's history of innovation in LEDs for lighting applications with wide viewing angle, symmetrical package, unlimited floor life and electrically neutral thermal path.

Cree XLamp LEDs bring high performance to a wide range of lighting applications, including color-changing, architectural, stage and studio, transportation, commercial and emergency-vehicle lighting.

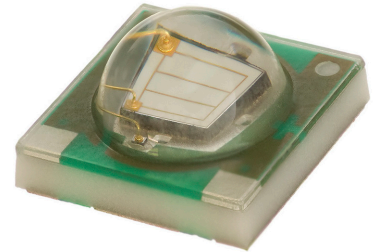

FEATURES

- Guaranteed minimum flux order codes
- Maximum drive current: 1000 mA
- Industry's lowest thermal resistance: 9°C/W
- Unlimited floor life at $\leq 30^\circ/85\%$ Rh
- Wide viewing angle
- Reflow solderable – JEDEC J-STD-020C compatible
- Electrically neutral thermal path
- RoHS-compliant

Table of Contents

Flux Characteristics ($T_j = 25^\circ\text{C}$) - Color	2
Characteristics	2
Relative Spectral Power Distribution	3
Relative Flux vs. Junction Temperature ($I_f = 350\text{ mA}$).....	3
Electrical Characteristics ($T_j = 25^\circ\text{C}$)	4
Thermal Design	4
Relative Flux vs. Current ($T_j = 25^\circ\text{C}$)	5
Typical Spatial Distribution	5
Reflow Soldering Characteristics	6
Notes.....	6
Mechanical Dimensions ($T_A = 25^\circ\text{C}$)	7
Tape and Reel	8
Packaging.....	9
Bin- and Order-Code Format	10
Performance Groups – Brightness	10
Performance Groups – Dominant Wavelength	10
Standard Order Codes and Bins	11

This is a preliminary, non-binding product specification provided for informational purposes only and is subject to change without notice. This product is unreleased and is provided "as is" without warranty.
www.cree.com/xlamp



Preliminary August 19, 2009

Flux Characteristics (T_j = 25°C) - Color

The following table provides the base order code for XLamp XP-E Royal Blue LEDs. It is important to note that the base order codes listed here are a subset of the total available order codes for the product family. For more order codes, as well as a complete description of the order-code nomenclature, please consult the XP-E & XP-C Binning and Labeling document.

Color	Dominant Wavelength Range				Base Order Codes Min Radiant Flux (mW)		Order Code
	Min.		Max.		Group	Flux (mW)	
	Group	DWL (nm)	Group	DWL (nm)			
Royal Blue	D3	450	D5	465	14	350	XPEROY-L1-0000-00901
					15	425	XPEROY-L1-0000-00A01

Note: Cree maintains a tolerance of +/- 7% on flux and power measurements.

Characteristics

Characteristics	Unit	Minimum	Typical	Maximum
Thermal Resistance, junction to solder point - royal blue	°C/W		9	
Viewing Angle (FWHM)	degrees		130	
Temperature coefficient of voltage - royal blue	mV/°C		-4.0	
ESD Classification (HBM per Mil-Std-883D)			Class 2	
DC Forward Current - royal blue	mA			1000
Reverse Voltage	V			5
Forward Voltage (@ 350 mA) - royal blue	V		3.2	3.9
Forward Voltage (@ 1000 mA) - royal blue	V		3.5	
LED Junction Temperature	°C			150

Relative Spectral Power Distribution

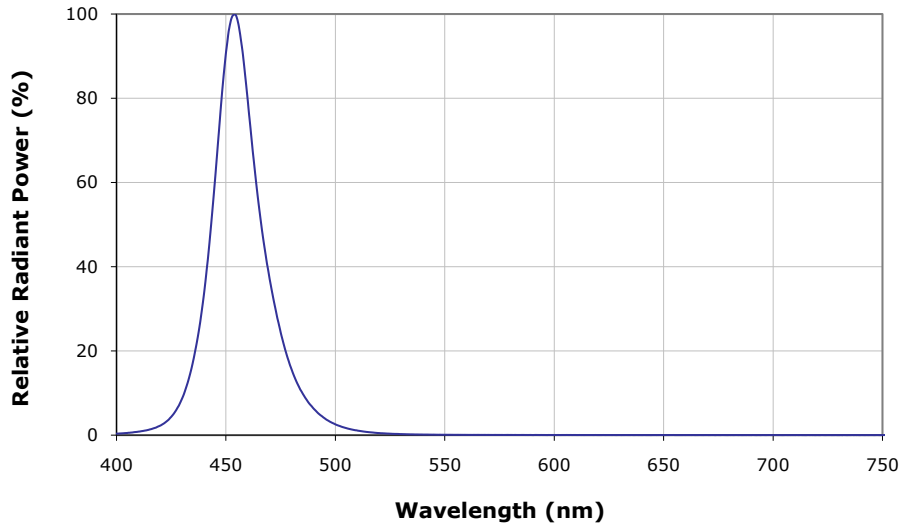

Relative Flux vs. Junction Temperature ($I_F = 350$ mA)

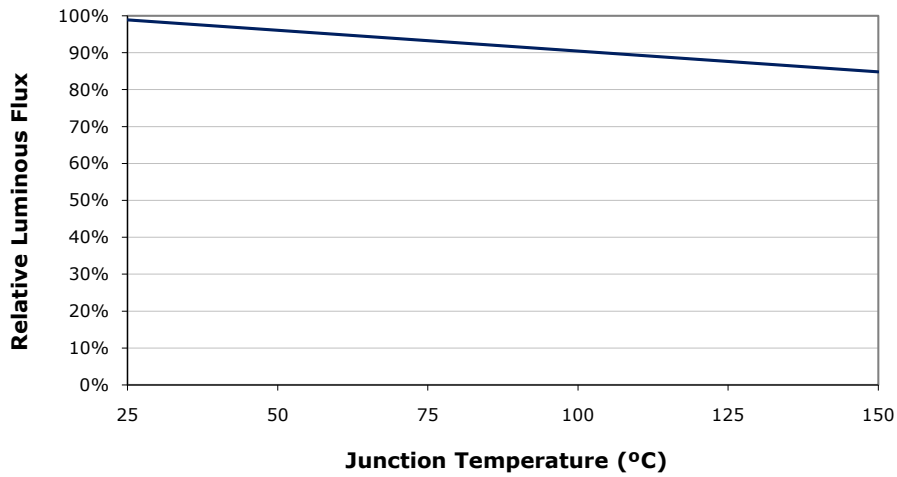

Electrical Characteristics ($T_j = 25^\circ\text{C}$)

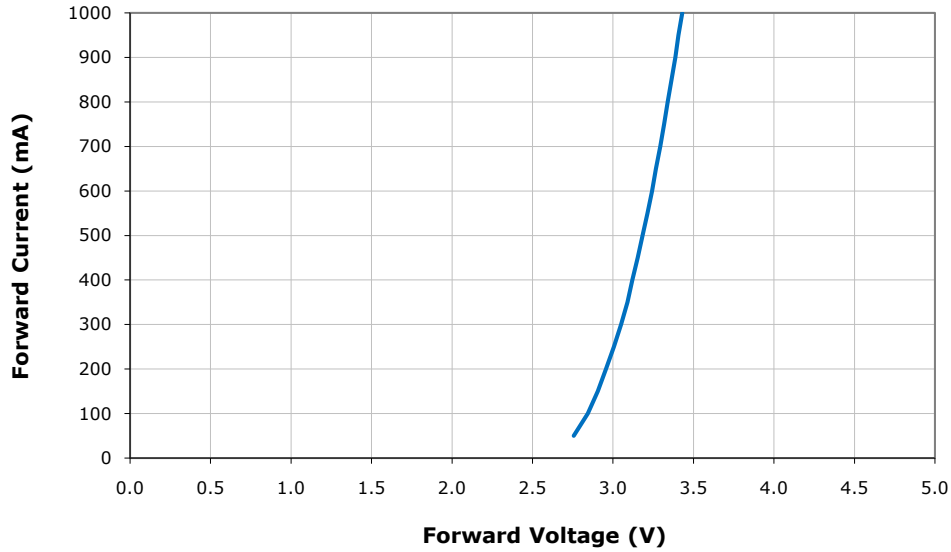

Thermal Design

The maximum forward current is determined by the thermal resistance between the LED junction and ambient. It is crucial for the end product to be designed in a manner that minimizes the thermal resistance from the solder point to ambient in order to optimize lamp life and optical characteristics.

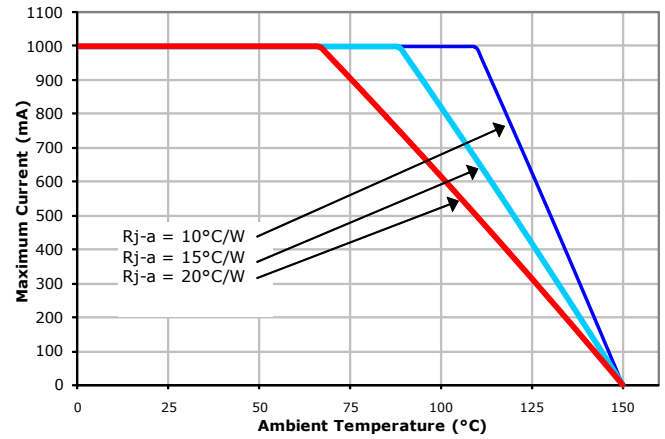

Relative Flux vs. Current ($T_1 = 25^\circ\text{C}$)

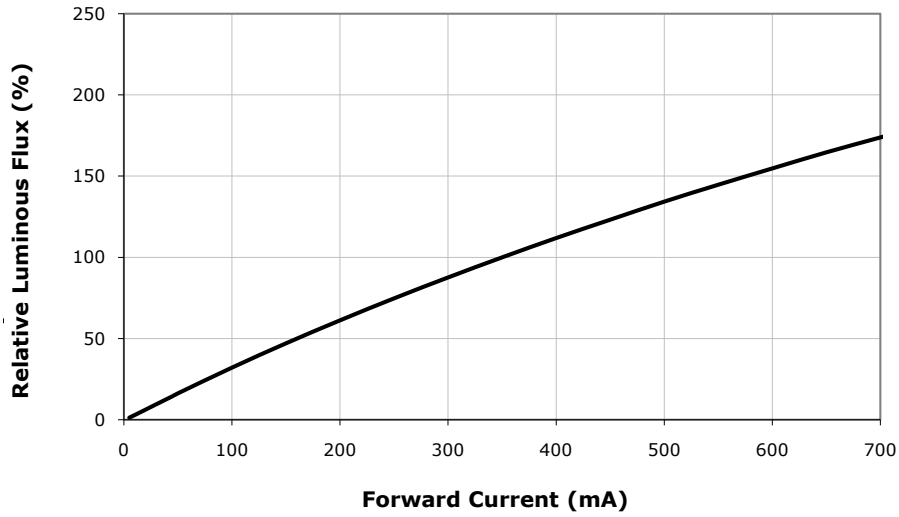

Typical Spatial Distribution

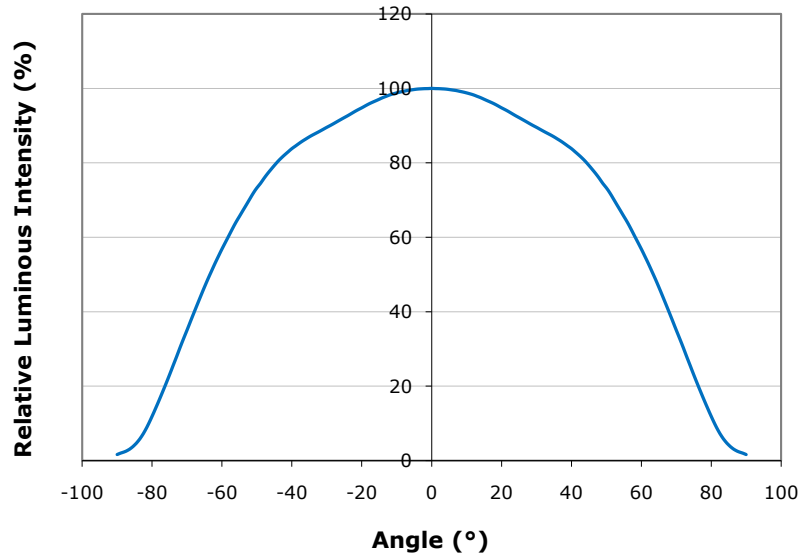

Reflow Soldering Characteristics

In testing, Cree has found XLamp XP-E LEDs to be compatible with JEDEC J-STD-020C, using the parameters listed below. As a general guideline, Cree recommends that users follow the recommended soldering profile provided by the manufacturer of solder paste used.

Note that this general guideline may not apply to all PCB designs and configurations of reflow soldering equipment.

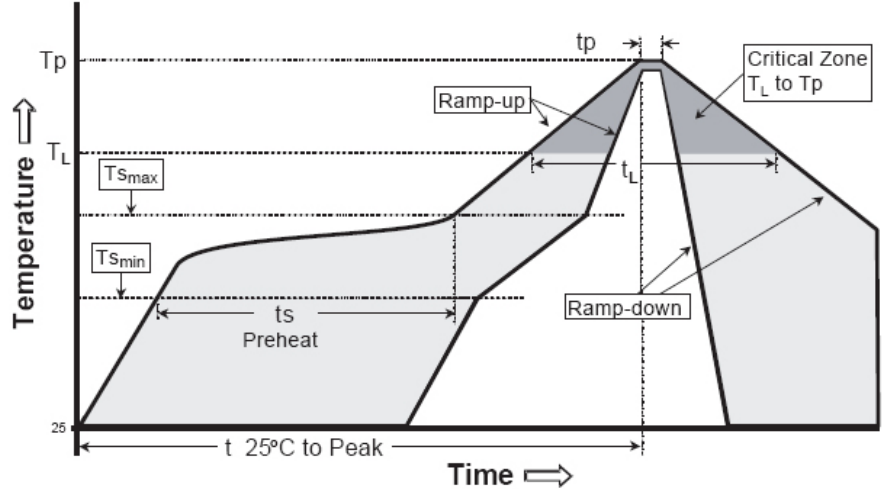

IPC/JEDEC J-STD-020C

Profile Feature	Lead-Based Solder	Lead-Free Solder
Average Ramp-Up Rate ($T_{S_{max}}$ to T_p)	3°C/second max.	3°C/second max.
Preheat: Temperature Min ($T_{S_{min}}$)	100°C	150°C
Preheat: Temperature Max ($T_{S_{max}}$)	150°C	200°C
Preheat: Time ($t_{S_{min}}$ to $t_{S_{max}}$)	60-120 seconds	60-180 seconds
Time Maintained Above: Temperature (T_L)	183°C	217°C
Time Maintained Above: Time (t_L)	60-150 seconds	60-150 seconds
Peak/Classification Temperature (T_p)	215°C	260°C
Time Within 5°C of Actual Peak Temperature (t_p)	10-30 seconds	20-40 seconds
Ramp-Down Rate	6°C/second max.	6°C/second max.
Time 25°C to Peak Temperature	6 minutes max.	8 minutes max.

Note: All temperatures refer to topside of the package, measured on the package body surface.

Notes

RoHS Compliance

The levels of environmentally sensitive, persistent biologically toxic (PBT), persistent organic pollutants (POP), or otherwise restricted materials in this product are below the maximum concentration values (also referred to as the threshold limits) permitted for such substances, or are used in an exempted application, in accordance with EU Directive 2002/95/EC on the restriction of the use of certain hazardous substances in electrical and electronic equipment (RoHS), as amended through April 21, 2006.

Vision Advisory Claim

Users should be cautioned not to stare at the light of this LED product. The bright light can damage the eye.

Mechanical Dimensions (T_A = 25°C)

All measurements are ±.13 mm unless otherwise indicated.

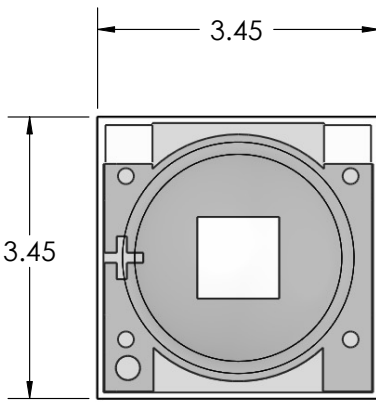
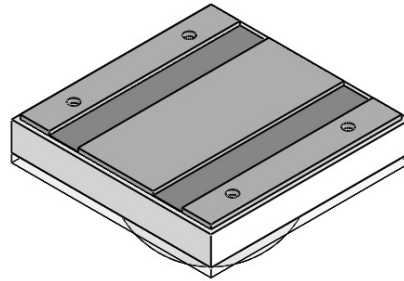
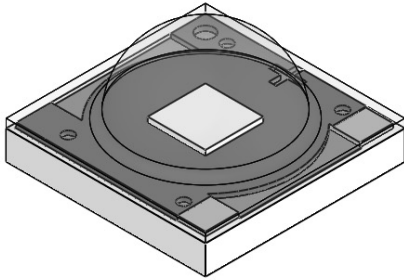

Top View

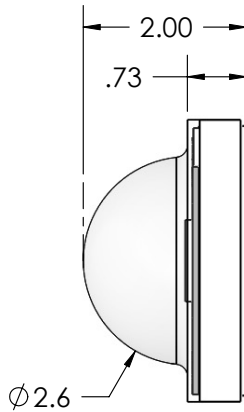

Side View

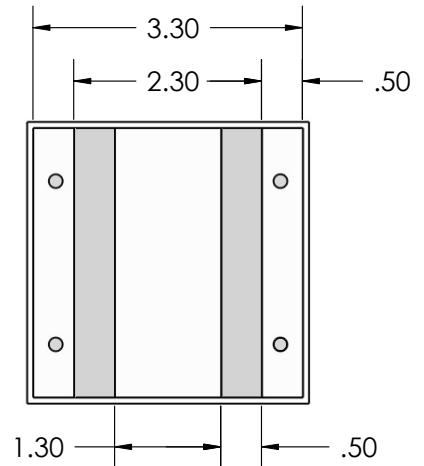

Bottom View

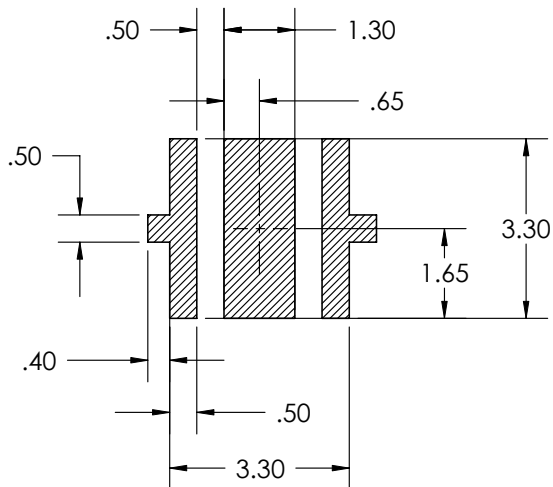

RECOMMENDED PCB SOLDER PAD

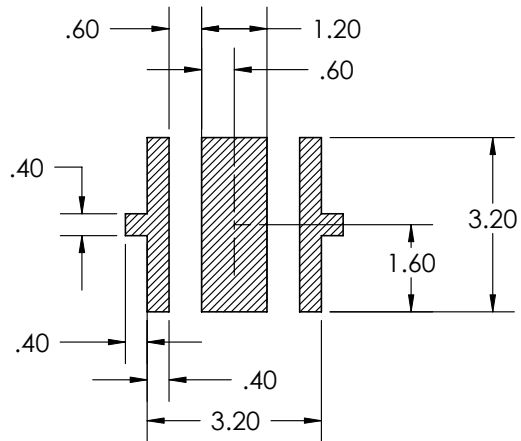

**RECOMMENDED STENCIL PATTERN
(HATCHED AREA IS OPENING)**

Tape and Reel

All dimensions in mm.

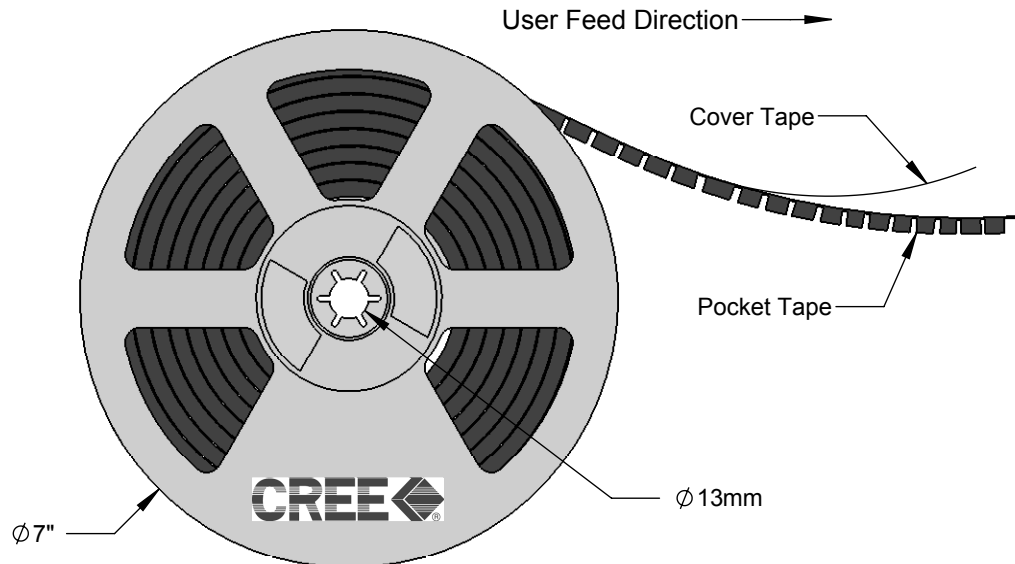
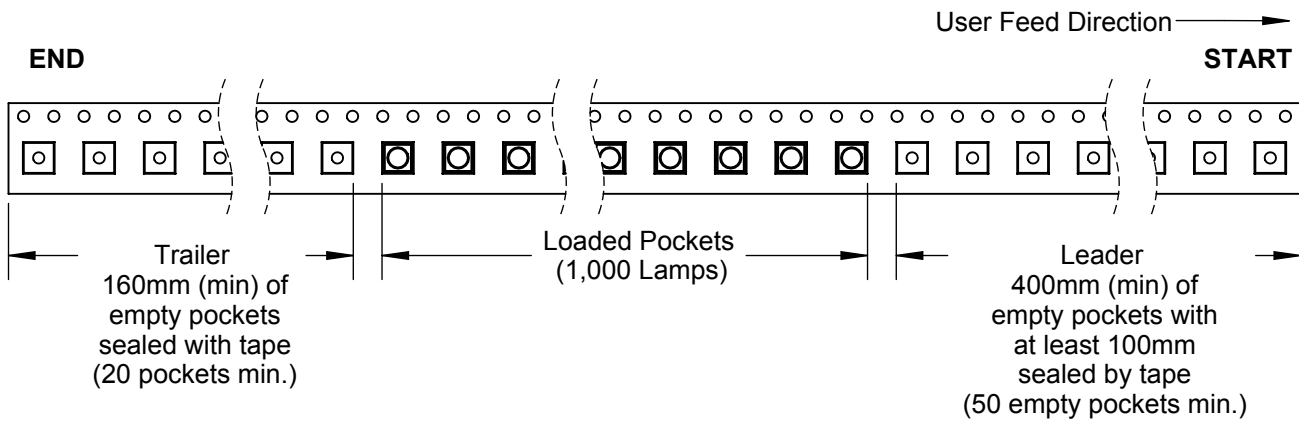
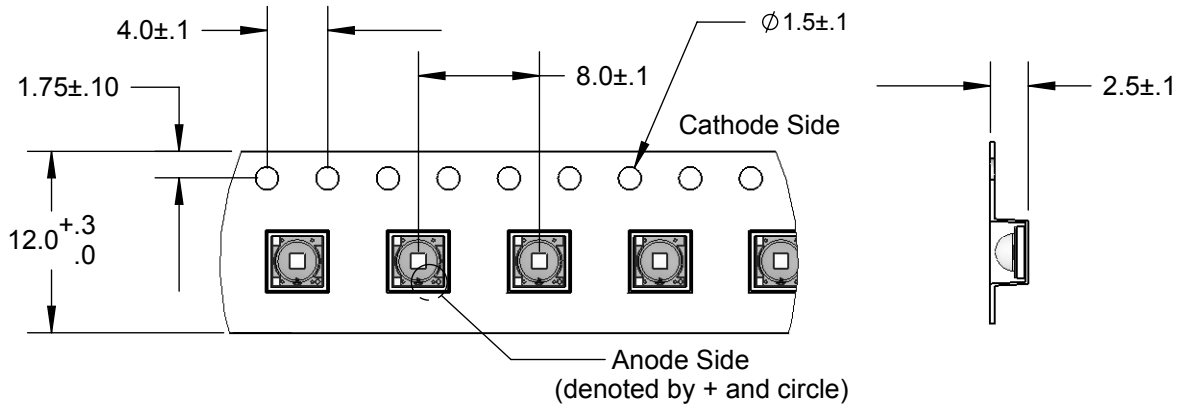

Packaging

All dimensions in mm.

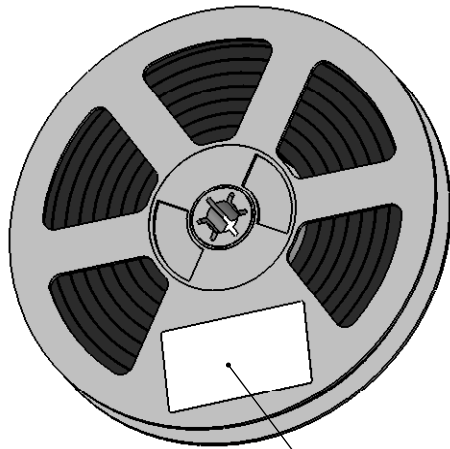

Label with Cree Bin Code, Qty, Lot #

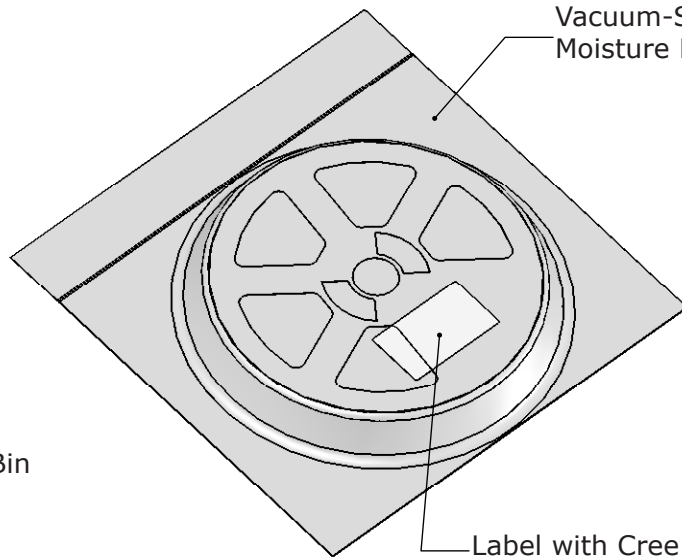

Vacuum-Sealed Moisture Barrier Bag

Label with Cree Bin Code, Qty, Lot #

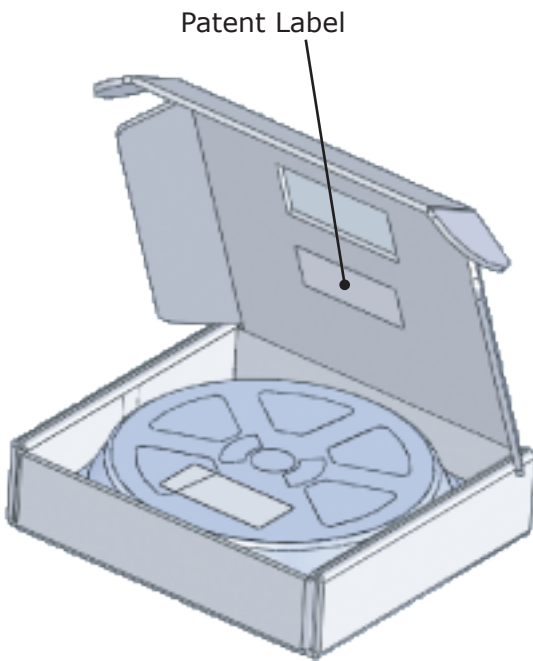

Patent Label

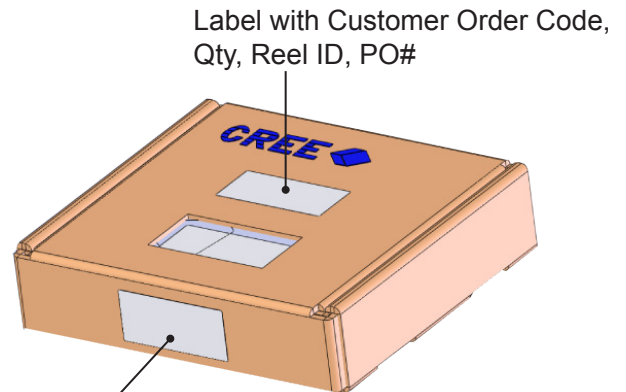

Label with Customer Order Code, Qty, Reel ID, PO#

Label with Cree Bin Code, Qty, Lot #

Bin- and Order-Code Format

Bin codes and order codes are configured in the following manner:

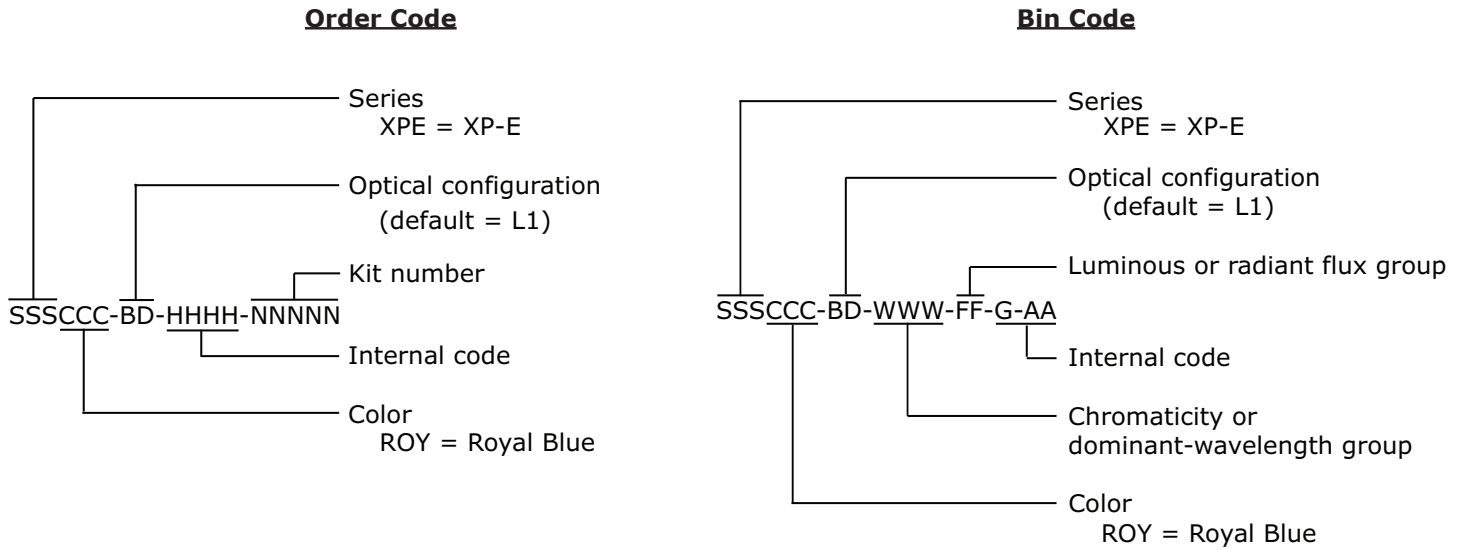

Performance Groups – Brightness

Royal-blue XLamp XP-E LEDs are tested for radiant flux and sorted into one of the following radiant-flux bins:

Group	Min. Radiant Flux (mW) @ 350 mA	Max. Radiant Flux (mW) @ 350 mA
14	350	425
15	425	500

Performance Groups – Dominant Wavelength

Color XLamp LEDs are tested for dominant wavelength (DWL) and sorted into one of the DWL bins defined below.

DWL Group	Min. DWL (nm) @ 350 mA	Max. DWL (nm) @ 350 mA
D3	450	455
D4	455	460
D5	460	465



Preliminary August 19, 2009

Standard Order Codes and Bins

The following tables list standard kit numbers and performance bins. Kit numbers completely describe an order code's dominant-wavelength range and or radiant-flux range.

Min. Radiant Flux (mW) @ 350 mA*		Dominant Wavelength (nm)				Kit Number
Group	Flux (mW)	Min.		Max.		
		Group	DWL (nm)	Group	DWL (nm)	
14	350	D3	450	D5	465	00901
		D3	450	D4	460	00902
		D4	455	D5	465	00903
15	425	D3	450	D5	465	00A01
		D3	450	D4	460	00A02
		D4	455	D5	465	00A03