

Features

- High brightness (InGaN/SiC) die material
- Available in green (525nm), bluish-green (505nm) and blue (470nm) colors
- Reflow and dip soldering compatible
- Available for both standard and reverse mounting
- 1000V minimum ESD protection

Applications

- Automotive indicator display
- Various other backlight uses

Outline Dimensions

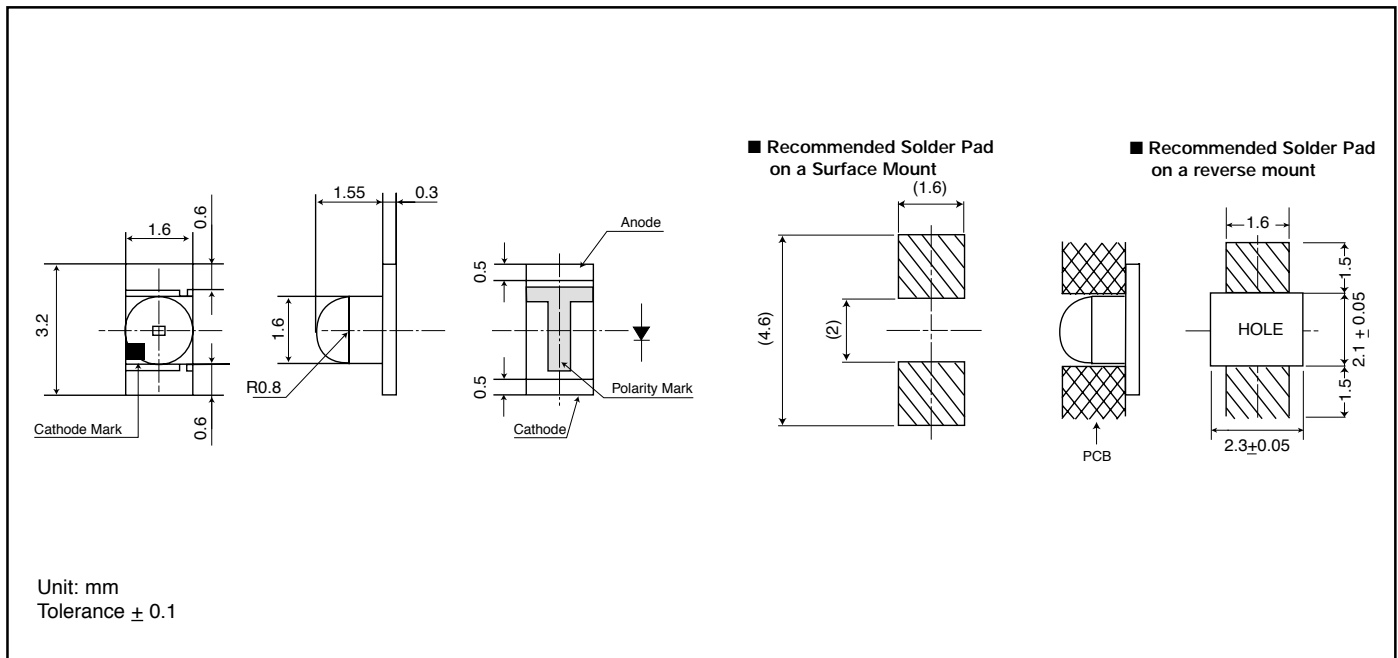

Electro-Optical Characteristics

(Ta=25°C)

Part No.	Material	Emitted Color	Lens Color	Luminous Intensity I _v			Wavelength				Forward Voltage v _f			Reverse Current I _r		Viewing Angle (2 θ 1/2)
				MIN.	TYP.	I _f	Peak λ _p TYP.	Dominant λ _d TYP.	Spectral Line Half Width Δλ TYP.	I _f	TYP.	MAX.	I _f	MAX.	V _r	
HDG1105W	InGaN/SiC	Green	Water Clear	70	140	10	522	525	30	10	3.3	3.8	10	100	5	40°
HDC1105W	InGaN/SiC	Bluish-Green		70	140	10	502	505	30	10	3.3	3.8	10	100	5	
HDB1105W	InGaN/SiC	Blue		35	70	10	467	470	26	10	3.3	3.8	10	100	5	
Units				mcd	mA		nm			mA		V		μA	V	Deg.

Absolute Maximum Ratings

(Ta=25°C)

Item	Symbol	Green	Bluish-Green	Blue	Units
		HDG	HDC	HDB	
Power Dissipation	Pd	76	76	76	mW
Forward Current	I _F	20	20	20	mA
Peak Forward Current	I _{FM}	48	48	48	mA
Reverse Voltage	V _R	5	5	5	V
Operating Temperature	Topr	-40 to +85			°C
Storage Temperature	Tstg	-40 to +100			°C
Derating*	ΔI _F	0.28 (DC) 0.69 (Pulse)			mA/°C

* Ta=25°C, I_{FM} applies for the pulse width ≤ 1msec. and duty cycle ≤ 1/20.

Taping Specifications for Reverse Mount Type

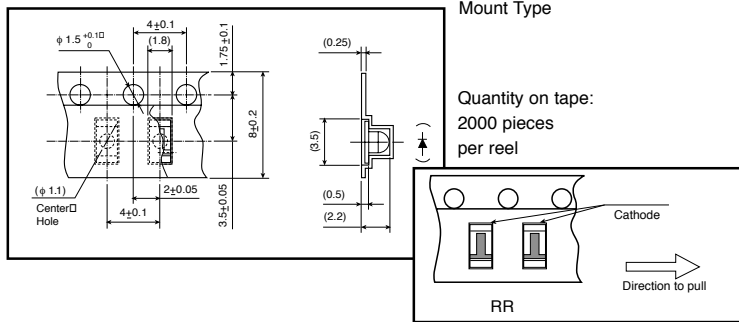

Taping Specifications for Standard Mount Type

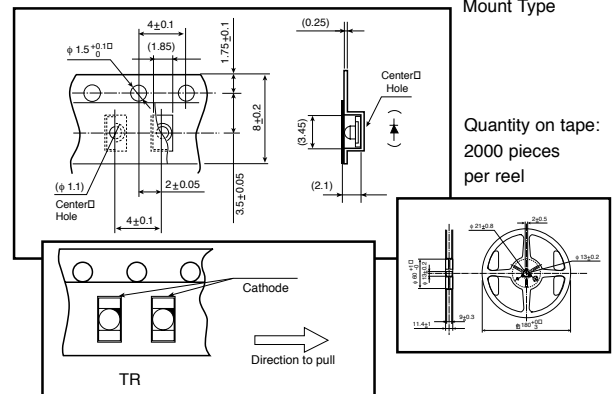

Operation Current Derating Chart (DC)

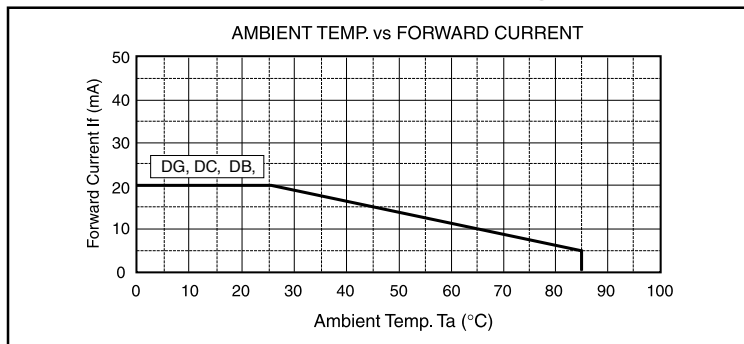

Spatial Distribution

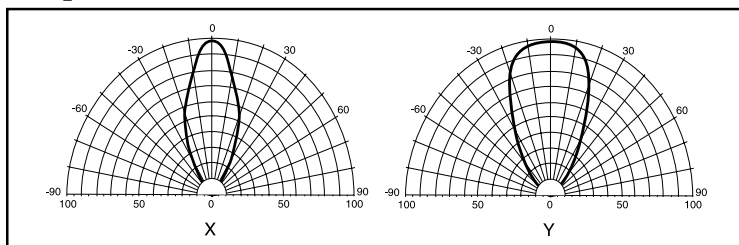

Precautions

Please follow these handling precautions to prevent damage to the chip and ensure its reliability.

1. Soldering conditions:

- **Soldering iron:** Temperature at tip of iron: 280°C max. (30W max.) Soldering time: 3 sec. max.
- **Dip soldering:** Preheating: 120 ~ 150°C max. (resin surface temp.) 60 ~ 120 sec. max. Bath temperature: 260°C max. Dipping Time: 5 sec. max.
- **Reflow Soldering:**

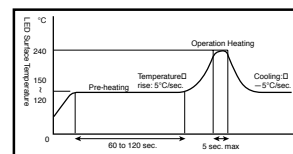

2. Cleaning:

- If cleaning is required, use the following solutions for less than 1 minute, at less than 40°C.
- Appropriate chemicals: Ethyl alcohol and isopropyl alcohol.
- Effect of ultrasonic cleaning on the LED resin body differs depending on such factors as the oscillator output, size of PCB and LED mounting method. The use of ultrasonic cleaning should be enforced at proper output after confirming there is no problem.

Product specifications subject to change without notice. PGHD1105W-0301

Stanley Electric Sales of America, Inc.

2660 Barranca Parkway, Irvine, CA 92606 • Tel: 800-LED-LCD1 (533-5231) • Fax: 949-222-0555
Website: www.stanley-electric.com

