

UNCONTROLLED DOCUMENT

PART NUMBER
SML-LXIL3333SIC-TR

REV.

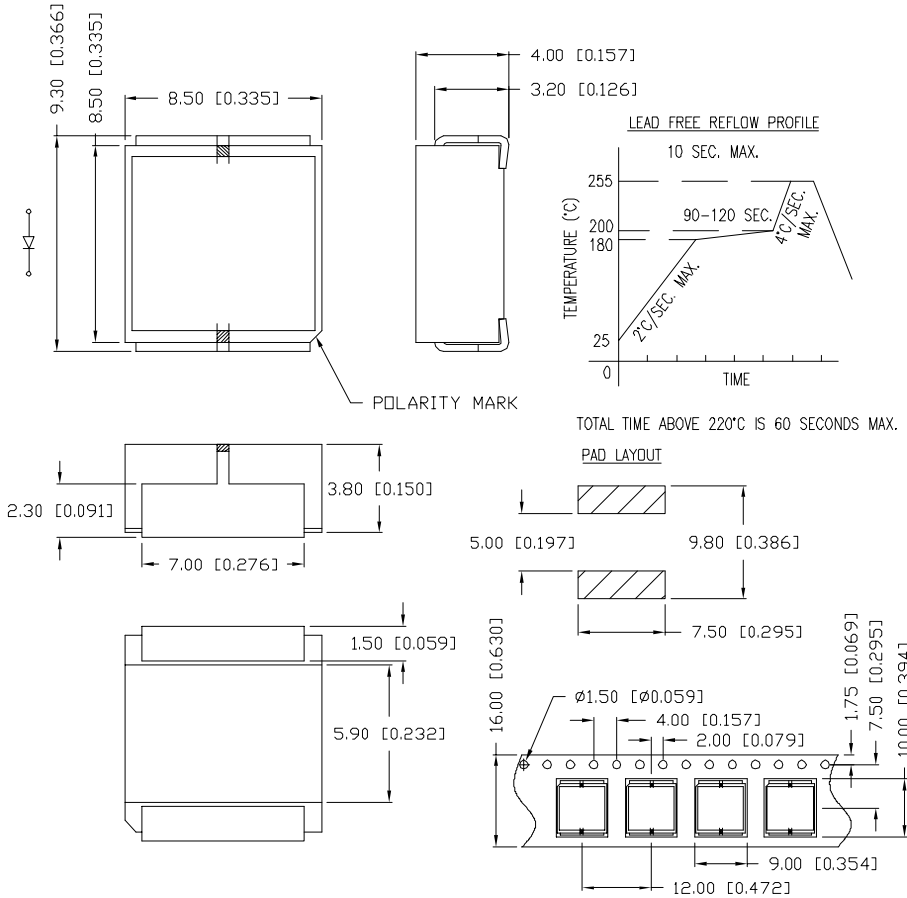

ELECTRO-OPTICAL CHARACTERISTICS $T_A=25^\circ\text{C}$ $I_f=20\text{mA}$

PARAMETER	SYMBOL	MIN	TYP	MAX	UNITS	TEST COND
PEAK WAVELENGTH			625		nm	
FORWARD VOLTAGE	V_f		2.2		V	$I_f=20\text{mA}$
REVERSE VOLTAGE	V_r	5			V	$I_r=10\mu\text{A}$
AXIAL INTENSITY	I_v		50000		mcd	$I_f=20\text{mA}$
VIEWING ANGLE			14		$2x$ theta	
EMITTED COLOR:	RED					
EPOXY LENS FINISH:	WATER CLEAR					

LIMITS OF SAFE OPERATION AT 25°C

PARAMETER	SYMBOL	MAX	UNITS
PULSE FORWARD CURRENT*	I_p	100	mA
STEADY CURRENT	I_f	30	mA
POWER DISSIPATION	P_D	130	W
OPERATING TEMP.	T_{OPR}	-20 TO +85	$^\circ\text{C}$
STORAGE TEMP.	T_{STG}	-30 TO +90	$^\circ\text{C}$

*DUTY 1/10 PULSE WIDTH 10ms

NOTES:

CATHODE IS ORIENTED TOWARDS THE TAPE SPOCKET HOLE.

CAUTION: MOISTURE SENSITIVE DEVICE
PER JEDEC LEVEL 4 STANDARDS



UNCONTROLLED DOCUMENT

*UNLESS OTHERWISE SPECIFIED TOLERANCES PER DECIMAL PRECISION ARE: X=±1 (±0.039), X.X=±0.5 (±0.020), X.XX=±0.25 (±0.010), X.XXX=±0.127 (±0.005). LEAD SIZE=±0.05 (±0.002), LEAD LENGTH=±0.75 (±0.030), MIN.=+DECIMAL PRECISION -0.00, MAX.=+0.00 -DECIMAL PRECISION

REV.	PART NUMBER SML-LXIL3333SIC-TR
NARROW BEAM 8mm STM LED, 625nm RED LED, WATER CLEAR LENS.	

CONFIDENTIAL INFORMATION
THE INFORMATION CONTAINED IN THIS DOCUMENT IS THE PROPERTY OF LUMEX INC. EXCEPT AS SPECIFICALLY AUTHORIZED IN WRITING BY LUMEX INC., THE HOLDER OF THIS DOCUMENT SHALL KEEP ALL INFORMATION CONTAINED HEREIN CONFIDENTIAL AND SHALL PROTECT SAME IN WHOLE OR IN PART FROM DISCLOSURE AND DISSEMINATION TO ALL THIRD PARTIES.

RELIABILITY NOTE
OUR MANY YEARS OF EXPERIENCE DATA ACCUMULATION INDICATE THAT SOLDER HEAT IS A MAJOR CAUSE OF EARLY AND FUTURE FAILURE. PLEASE PAY ATTENTION TO YOUR SOLDERING PROCESS.

LUMEX An ITW Company		290 E. HELEN ROAD PALATINE, IL 60067-6976 PHONE: +1.847.359.2790 US WEB: www.lumex.com TW WEB: www.lumex.com.tw	
DRAWN BY: JN	CHECKED BY:	APPROVED BY:	DATE: 01.28.09 PAGE: 1 OF 1 SCALE: N/A