

Agilent HLMP-CW18, HLMP-CW19, HLMP-CW28, HLMP-CW29, HLMP-CW38, HLMP-CW39 T-1 3/4 Precision Optical Performance White LED Data Sheet

Description

These Super Bright Precision Optical Performance LED lamps are based on flip chip InGaN material, which is the brightest and most efficient technology for LEDs. A blue LED die is coated by a phosphor to produce white.

Package Dimension A

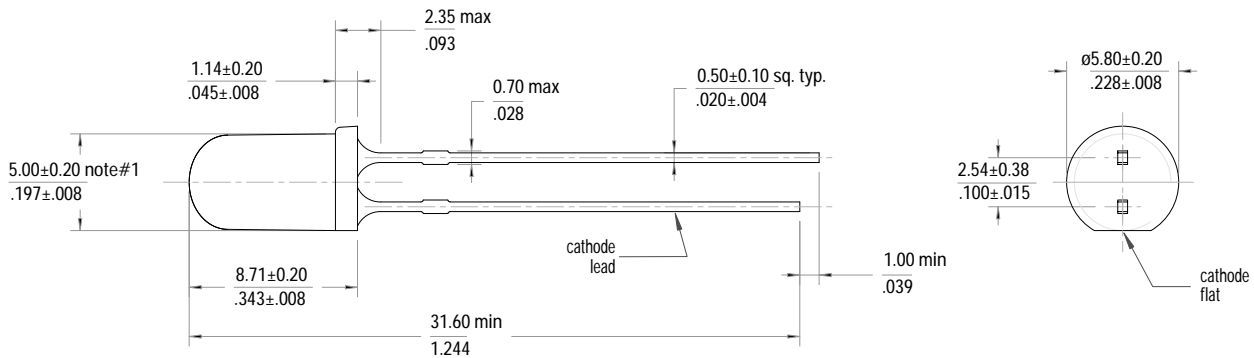

Package Dimension B

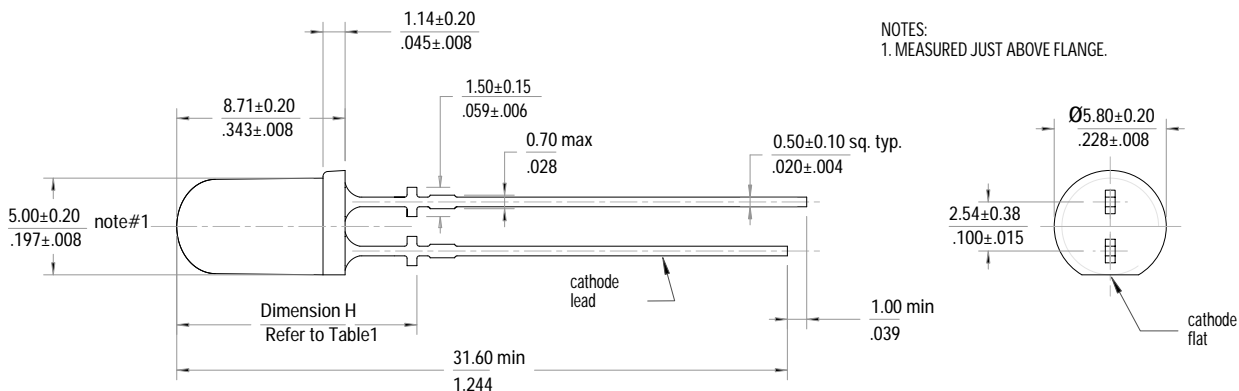

Features

- Highly Luminous White Emission
- 15° , 23° , and 30° viewing angle
- New InGaN flip chip die technology with protective diode.
- ESD class 3

Applications

- Electronic Signs and Signals
- Small Area Illumination
- Legend Backlighting
- General Purpose Indicators

These T-1 3/4 lamps incorporate precise optics producing well-defined spatial radiation patterns at specific viewing cone angle.

Benefit

- Reduced Power Consumption, Higher Reliability, and Increased Optical/Mechanical Design Flexibility Compared to Incandescent Bulbs and Other Alternative White Light Sources

NOTES:
1. MEASURED JUST ABOVE FLANGE.

Dimension H:

- 23 & 30 Degree = $12.67 \pm 0.25 \text{ mm}$ ($0.499 \pm 0.01 \text{ inch}$)
- 15 Degree = $12.93 \pm 0.25 \text{ mm}$ ($0.509 \pm 0.01 \text{ inch}$)

Notes :

1. All dimensions are in millimetres /inches.
2. Epoxy meniscus may extend about 1mm (0.040") down the leads.



Device Selection Guide

Part Number	Typ. Viewing Angle	Iv (cd) @ 20mA		Standoff Leads	Package Dimension
		Min.	Typ.		
HLMP-CW18-VY0xx	15°	4.20	6.40	No	A
HLMP-CW19-VY0xx	15°	4.20	6.40	Yes	B
HLMP-CW28-TW0xx	23°	2.50	3.80	No	A
HLMP-CW29-TW0xx	23°	2.50	3.80	Yes	B
HLMP-CW38-SV0xx	30°	1.90	3.00	No	A
HLMP-CW39-SV0xx	30°	1.90	3.00	Yes	B

Notes:

1. Tolerance for luminous intensity measurement is +/- 15%
2. The luminous intensity is measured on the mechanical axis of the lamp package.
3. The optical axis is closely aligned with the package mechanical axis.
4. LED light output is bright enough to cause injuries to the eyes. Precautions must be taken to prevent looking directly at the LED with unprotected eyes.

Part Numbering System

LM P - C W XX - X X X XX

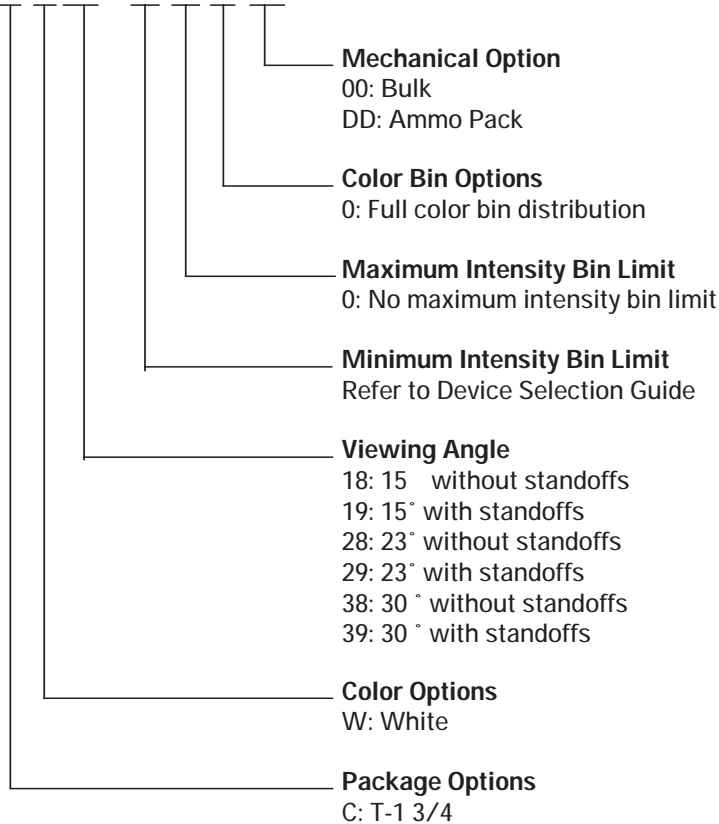

Absolute Maximum Ratings ($T_A = 25^\circ\text{C}$)

Parameter	Value	Units
DC Forward Current ^[1]	30	mA
Peak Forward Current ^[2]	100	mA
Average Forward Current	30	mA
Power Dissipation	120	mW
LED Junction Temperature	130	°C
Operating Temperature Range	-40 to +85	°C
Storage Temperature Range	-40 to +100	°C

Notes:

1. Derate linearly as shown in Figure 4.
2. Duty Factor 30%, 1 KHz

Electrical/Optical Characteristics ($T_A = 25^\circ\text{C}$)

Parameters	Symbol	Minimum	Typical	Maximum	Units	Test Condition
Forward voltage	V_F		3.4	4.0	V	$I_F = 20\text{ mA}$
Capacitance	C		53		pF	$V_F=0, f=1\text{ MHz}$
Reverse Voltage ^[1]	V_R		0.6		V	$I_R = 10\text{ mA}$
Thermal resistance	R_{qJ-PIN}		240		°C/W	LED Junction to cathode lead
Viewing Angle ^[2]	$2q_{1/2}$				Degree	$I_F = 20\text{ mA}$
CW18/CW19			15			
CW28/CW29			23			
CW38/CW39			30			
Chromaticity Coordinate ^[3]	X		0.31			$I_F = 20\text{ mA}$
	Y		0.32			

Notes:

1. The reverse voltage of the product is equivalent to the forward voltage of the protective chip at $I_R = 10\text{ mA}$
2. $2q_{1/2}$ is the off-axis angle where the luminous intensity is $\frac{1}{2}$ the on axis intensity
3. The chromaticity coordinates are derived from the CIE 1931 Chromaticity Diagram and represent the perceived color of the device.
4. The radiant intensity, I_e in watts/steradian, may be found from the equation $I_e = I_v/h_v$, where I_v is the luminous intensity in candelas and h_v is the luminous efficacy in lumens/watt.

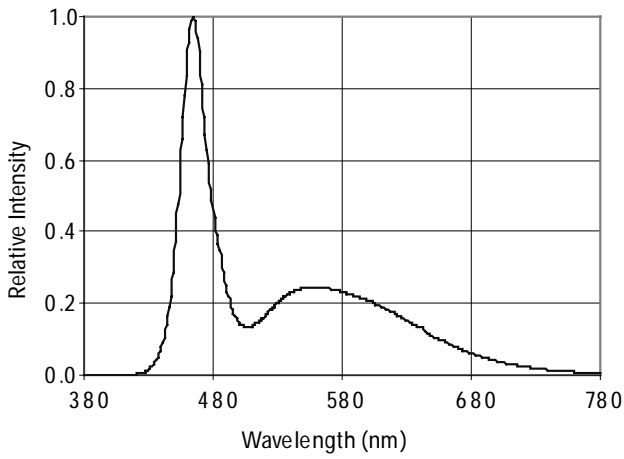

Figure 1. Relative Intensity vs Wavelength

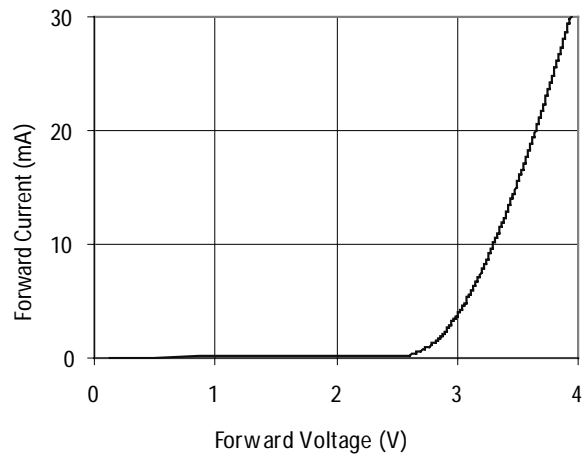

Figure 2. Forward Current vs Forward Voltage

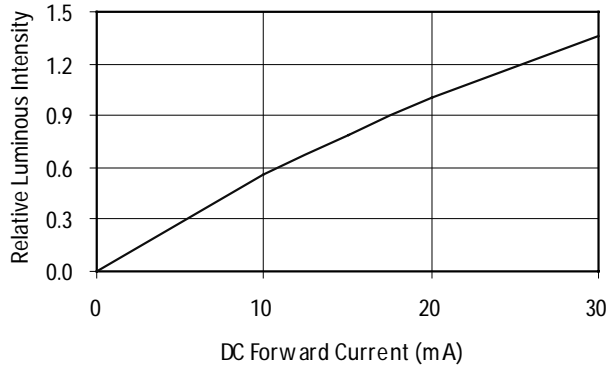

Figure 3. Relative Iv vs. Forward Current

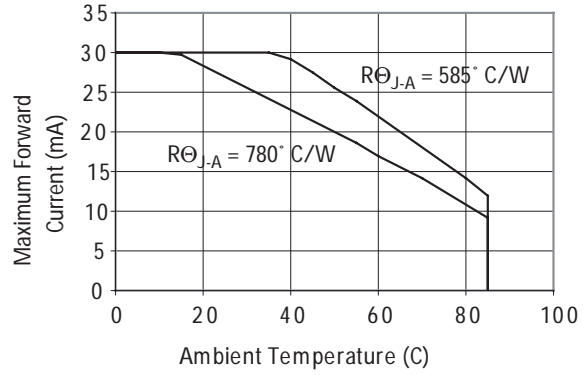

Figure 4. Maximum Fwd Current vs Temperature

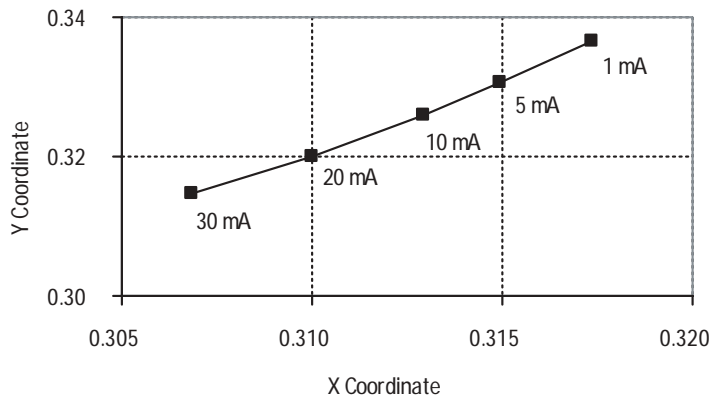

Figure 5. Chromaticity Coordinates Changes over Forward Current

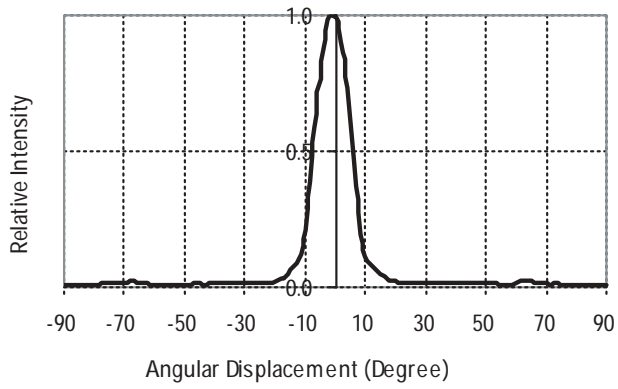

Figure 6a. CW1x Spatial Radiation Pattern

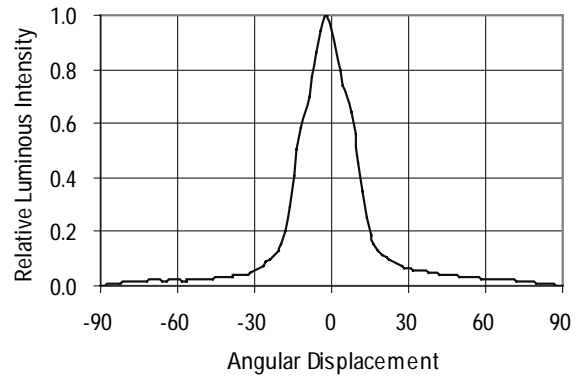

Figure 6b. CW2x Spatial Radiation Pattern

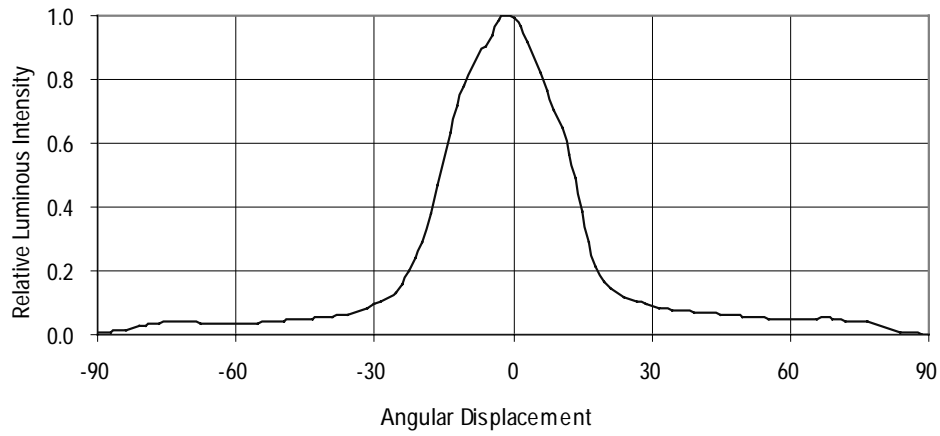

Figure 6c. CW3x Spatial Radiation Pattern

Intensity Bin Limit Table

Bin	Intensity (mcd) at 20 mA	
	Min	Max
S	1900	2500
T	2500	3200
U	3200	4200
V	4200	5500
W	5500	7200
X	7200	9300
Y	9300	12000

Tolerance for each bin limit is $\pm 15\%$

Color Bin Limit Tables

Rank	Limits (Chromaticity Coordinates)				
	1	x y	0.330 0.360	0.330 0.318	0.356 0.351
2	x y	0.287 0.295	0.296 0.276	0.330 0.318	0.330 0.339
3	x y	0.264 0.267	0.280 0.248	0.296 0.276	0.283 0.305
4	x y	0.283 0.305	0.287 0.295	0.330 0.339	0.330 0.360

Tolerance for each bin limit is ± 0.01

Note:

1. Bin categories are established for classification of products. Products may not be available in all bin categories. Please contact your Agilent representative for information on currently available

Color Bin Limits with Respect to CIE 1931 Chromaticity Diagram

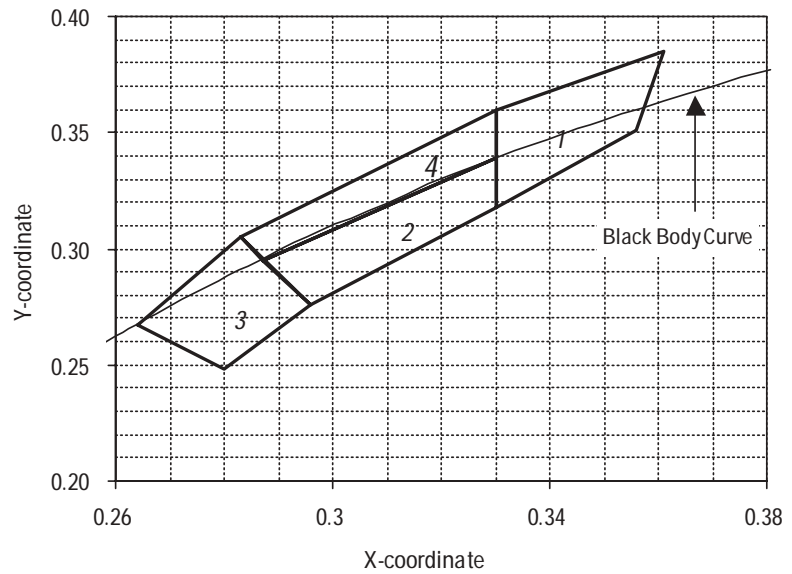

Precautions:

Lead Forming:

- The leads of an LED lamp may be preformed or cut to length prior to insertion and soldering into PC board.
- If lead forming is required before soldering, care must be taken to avoid any excessive mechanical stress induced to LED package. Otherwise, cut the leads of LED to length after soldering process at room temperature. The solder joint formed will absorb the mechanical stress of the lead cutting from traveling to the LED chip die attach and wirebond.
- It is recommended that tooling made to precisely form and cut the leads to length rather than rely upon hand operation.

Soldering Condition:

- Care must be taken during PCB assembly and soldering process to prevent damage to LED component.
- The closest LED is allowed to solder on board is 1.59mm below the body (encapsulant epoxy) for those parts without standoff.
- Recommended soldering condition:

	Wave Soldering	Manual Solder Dipping
Pre-heat temperature	105 °C Max.	–
Preheat time	30 sec Max	–
Peak temperature	250 °C Max.	260 °C Max.
Dwell time	3 sec Max.	5 sec Max

- Wave soldering parameter must be set and maintain according to recommended temperature and dwell time in the solder wave. Customer is advised to periodically check on the soldering profile to ensure the soldering profile used is always conforming to recommended soldering condition.
- If necessary, use fixture to hold the LED component in proper orientation with respect to the PCB during soldering process.
- Proper handling is imperative to avoid excessive thermal stresses to LED components when heated. Therefore, the soldered PCB must be allowed to cool to room temperature, 25°C before handling.
- Special attention must be given to board fabrication, solder masking, surface plating and lead holes size and component orientation to assure solderability.
- Recommended PC board plated through holes

LED component lead size	Diagonal	Plated through hole diameter
0.457 x 0.457mm (0.018 x 0.018inch)	0.646 mm (0.025 inch)	0.976 to 1.078 mm (0.038 to 0.042 inch)
0.508 x 0.508mm (0.020 x 0.020inch)	0.718 mm (0.028 inch)	1.049 to 1.150mm (0.041 to 0.045 inch)

Note: Refer to application note AN1027 for more information on soldering LED components.

Recommended Wave Soldering Profile

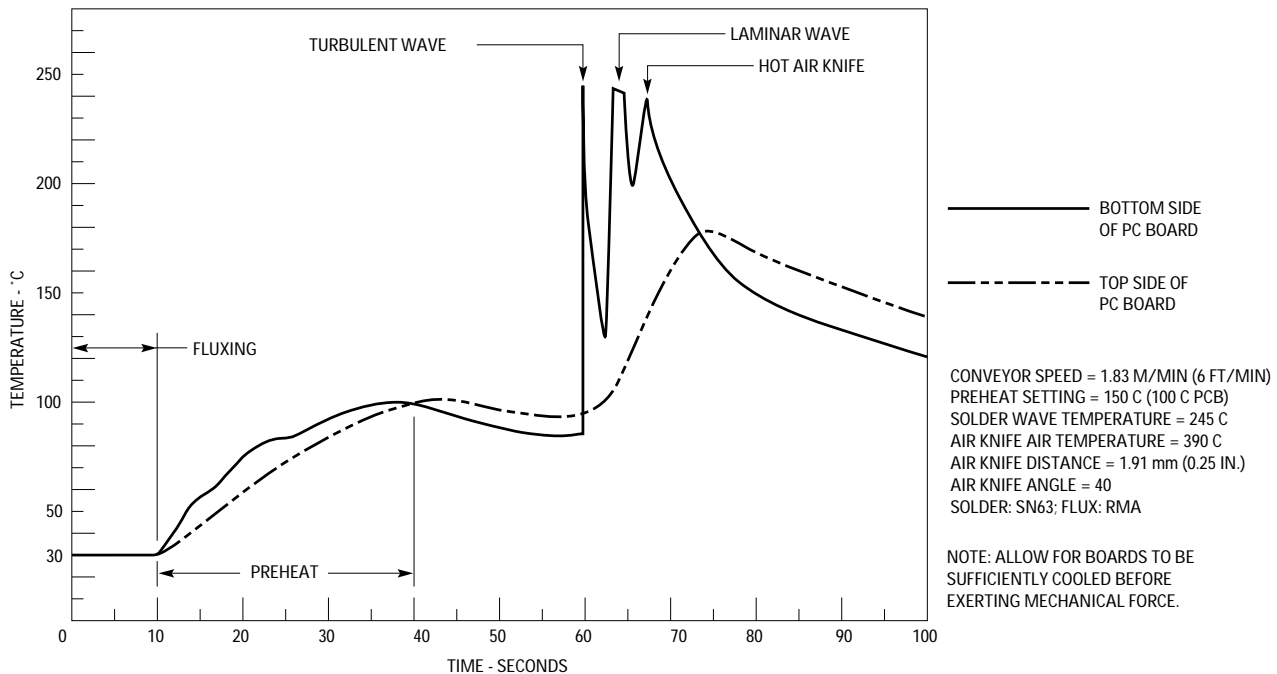

**[www.agilent.com/
semiconductors](http://www.agilent.com/semiconductors)**

For product information and a complete list
of distributors, please go to our web site.

Data subject to change.
Copyright 2005 Agilent Technologies, Inc.
October 27, 2005
Obsoletes 5989-0461EN
5989-4155EN

