

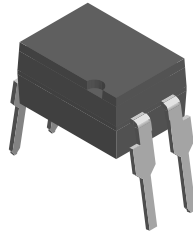

# Optocoupler, Phototransistor Output, High Reliability, 5300 V<sub>RMS</sub>



1179060



## DESCRIPTION

The SFH615XXX features a large assortment of current transfer ratio, low coupling capacitance and high isolation voltage. These couplers have a GaAs infrared emitting diode emitter, which is optically coupled to a silicon planar phototransistor detector, and is incorporated in a plastic DIP-4 package.

The coupling devices are designed for signal transmission between two electrically separated circuits.

The couplers are end-stackable with 2.54 mm lead spacing. Creepage and clearance distances of > 8 mm are achieved with option 6. This version complies with 60950 (DIN VDE 0805) for reinforced insulation up to operation voltage of 400 V<sub>RMS</sub> or DC.

## FEATURES

- Low CTR degradation
- Good CTR linearity depending on forward current
- Isolation test voltage, 5300 V<sub>RMS</sub>
- High collector emitter voltage, V<sub>CEO</sub> = 70 V
- Low saturation voltage
- Fast switching times
- Temperature stable
- Low coupling capacitance
- End stackable, 0.100" (2.54 mm) spacing
- High common mode interference immunity (unconnected base)
- Lead (Pb)-free component
- Component in accordance to RoHS 2002/95/EC and WEEE 2002/96/EC



**RoHS**  
COMPLIANT

## AGENCY APPROVALS

- UL1577, file no. E52744 system code H or J, double protection
- DIN EN 60747-5-5 (VDE 0884) available with option 1
- BSI IEC 60950; IEC 60065

## ORDER INFORMATION

| PART           | REMARKS                                    |
|----------------|--|
| SFH615AA       | CTR 50 to 600 %, DIP-4                     |
| SFH615AB       | CTR 80 to 260 %, DIP-4                     |
| SFH615ABL      | CTR 200 to 600 %, DIP-4                    |
| SFH615ABM      | CTR 200 to 400 %, DIP-4                    |
| SFH615AGB      | CTR 100 to 600 %, DIP-4                    |
| SFH615AGR      | CTR 100 to 300 %, DIP-4                    |
| SFH615AY       | CTR 50 to 150 %, DIP-4                     |
| SFH615AA-X006  | CTR 50 to 600 %, DIP-4 400 mil (option 6)  |
| SFH615AA-X007  | CTR 50 to 600 %, SMD-4 (option 7)          |
| SFH615ABM-X006 | CTR 200 to 400 %, DIP-4 400 mil (option 6) |
| SFH615ABM-X007 | CTR 200 to 400 %, SMD-4 (option 7)         |
| SFH615AGB-X006 | CTR 100 to 600 %, DIP-4 400 mil (option 6) |
| SFH615AGB-X009 | CTR 100 to 600 %, SMD-4 (option 9)         |
| SFH615AGR-X006 | CTR 100 to 300 %, DIP-4 400 mil (option 6) |
| SFH615AGR-X007 | CTR 100 to 300 %, SMD-4 (option 7)         |
| SFH615AY-X006  | CTR 50 to 150 %, DIP-4 400 mil (option 6)  |
| SFH615AY-X008  | CTR 50 to 150 %, SMD-4 (option 8)          |
| SFH615AY-X009  | CTR 50 to 150 %, SMD-4 (option 9)          |

### Note

For additional information on the available options refer to option information.

| ABSOLUTE MAXIMUM RATINGS (1)   |   |                   |                    |                  |
|--|---|-------------------|--------------------|------------------|
| PARAMETER  | TEST CONDITION  | SYMBOL            | VALUE              | UNIT             |
| <b>INPUT</b>   |   |                   |                    |                  |
| Reverse voltage  |   | V <sub>R</sub>    | 6                  | V                |
| DC forward current   |   | I <sub>F</sub>    | 60                 | mA               |
| Surge forward current  | t <sub>p</sub> ≤ 10 ms                                      | I <sub>FSM</sub>  | 2.5                | A                |
| Power dissipation  |   | P <sub>diss</sub> | 100                | mW               |
| <b>OUTPUT</b>  |   |                   |                    |                  |
| Collector emitter voltage  |   | V <sub>CE</sub>   | 70                 | V                |
| Emitter collector voltage  |   | V <sub>EC</sub>   | 7                  | V                |
| Collector current  |   | I <sub>C</sub>    | 50                 | mA               |
|  | t <sub>p</sub> ≤ 10 ms                                      | I <sub>C</sub>    | 100                | mA               |
| Total power dissipation  |   | P <sub>diss</sub> | 150                | mW               |
| <b>COUPLER</b>   |   |                   |                    |                  |
| Isolation test voltage between emitter and detector  |   | V <sub>ISO</sub>  | 5300               | V <sub>RMS</sub> |
| Creepage distance  |   |                   | ≥ 7                | mm               |
| Clearance distance   |   |                   | ≥ 7                | mm               |
| Isolation thickness between emitter and detector Comparative tracking index per DIN IEC 112/VDE 0303, part 1 |   | CTI               | ≥ 175              |                  |
| Isolation resistance   | V <sub>IO</sub> = 500 V, T <sub>amb</sub> = 25 °C           | R <sub>IO</sub>   | ≥ 10 <sup>12</sup> | Ω                |
|  | V <sub>IO</sub> = 500 V, T <sub>amb</sub> = 100 °C          | R <sub>IO</sub>   | ≥ 10 <sup>11</sup> | Ω                |
| Storage temperature range  |   | T <sub>stg</sub>  | - 55 to + 150      | °C               |
| Ambient temperature range  |   | T <sub>amb</sub>  | - 55 to + 100      | °C               |
| Soldering temperature (2)  | max. 10 s, dip soldering distance to seating plane ≥ 1.5 mm | T <sub>sld</sub>  | 260                | °C               |

**Notes**(1) T<sub>amb</sub> = 25 °C, unless otherwise specified.

Stresses in excess of the absolute maximum ratings can cause permanent damage to the device. Functional operation of the device is not implied at these or any other conditions in excess of those given in the operational sections of this document. Exposure to absolute maximum ratings for extended periods of the time can adversely affect reliability.

(2) Refer to reflow profile for soldering conditions for surface mounted devices (SMD). Refer to wave profile for soldering conditions for through hole devices (DIP).

| ELECTRICAL CHARACTERISTICS           |   |      |                    |      |      |      |      |
|--------------------------------------|---|------|--------------------|------|------|------|------|
| PARAMETER                            | TEST CONDITION                                  | PART | SYMBOL             | MIN. | TYP. | MAX. | UNIT |
| <b>INPUT</b>                         |   |      |                    |      |      |      |      |
| Forward voltage                      | I <sub>F</sub> = 60 mA                          |      | V <sub>F</sub>     |      | 1.25 | 1.65 | V    |
| Reverse current                      | V <sub>R</sub> = 6 V                            |      | I <sub>R</sub>     |      | 0.01 | 10   | μA   |
| Capacitance                          | V <sub>R</sub> = 0 V, f = 1 MHz                 |      | C <sub>O</sub>     |      | 13   |      | pF   |
| Thermal resistance                   |   |      | R <sub>thja</sub>  |      | 750  |      | K/W  |
| <b>OUTPUT</b>                        |   |      |                    |      |      |      |      |
| Collector emitter capacitance        | V <sub>CE</sub> = 5 V, f = 1 MHz                |      | C <sub>CE</sub>    |      | 5.2  |      | pF   |
| Thermal resistance                   |   |      | R <sub>thja</sub>  |      | 500  |      | K/W  |
| Collector emitter saturation voltage | I <sub>F</sub> = 10 mA, I <sub>C</sub> = 2.5 mA |      | V <sub>CEsat</sub> |      | 0.25 | 0.4  | V    |
| Coupling capacitance                 |   |      | C <sub>C</sub>     |      | 0.4  |      | pF   |



| ELECTRICAL CHARACTERISTICS        |                         |           |           |      |      |      |      |
|-----------------------------------|-------------------------|-----------|-----------|------|------|------|------|
| PARAMETER                         | TEST CONDITION          | PART      | SYMBOL    | MIN. | TYP. | MAX. | UNIT |
| <b>COUPLER</b>                    |                         |           |           |      |      |      |      |
| Collector emitter leakage current | $V_{CE0} = 10\text{ V}$ | SFH615AA  | $I_{CEO}$ |      | 10   | 100  | nA   |
|                                   |                         | SFH615AGB | $I_{CEO}$ |      | 10   | 100  | nA   |
|                                   |                         | SFH615AGR | $I_{CEO}$ |      | 10   | 100  | nA   |
|                                   |                         | SFH615ABM | $I_{CEO}$ |      | 10   | 100  | nA   |
|                                   |                         | SFH615ABL | $I_{CEO}$ |      | 10   | 100  | nA   |
|                                   |                         | SFH615AY  | $I_{CEO}$ |      | 10   | 100  | nA   |
|                                   |                         | SFH615AB  | $I_{CEO}$ |      | 10   | 100  | nA   |

**Note**

$T_{amb} = 25\text{ }^{\circ}\text{C}$ , unless otherwise specified.

Minimum and maximum values are testing requirements. Typical values are characteristics of the device and are the result of engineering evaluation. Typical values are for information only and are not part of the testing requirements.

| CURRENT TRANSFER RATIO |  |           |        |      |      |      |      |
|------------------------|--|-----------|--------|------|------|------|------|
| PARAMETER              | TEST CONDITION                           | PART      | SYMBOL | MIN. | TYP. | MAX. | UNIT |
| $I_C/I_F$              | $I_F = 5\text{ mA}, V_{CE} = 5\text{ V}$ | SFH615AA  | CTR    | 50   |      | 600  | %    |
|                        |  | SFH615AGB | CTR    | 100  |      | 600  | %    |
|                        |  | SFH615AGR | CTR    | 100  |      | 300  | %    |
|                        |  | SFH615ABM | CTR    | 200  |      | 400  | %    |
|                        |  | SFH615ABL | CTR    | 200  |      | 600  | %    |
|                        |  | SFH615AY  | CTR    | 50   |      | 150  | %    |
|                        |  | SFH615AB  | CTR    | 80   |      | 260  | %    |

| SWITCHING CHARACTERISTICS |                     |           |      |      |      |               |  |
|---------------------------|---------------------|-----------|------|------|------|---------------|--|
| PARAMETER                 | TEST CONDITION      | SYMBOL    | MIN. | TYP. | MAX. | UNIT          |  |
| Turn-on time              | $I_F = 5\text{ mA}$ | $t_{on}$  |      | 2    |      | $\mu\text{s}$ |  |
| Turn-off time             | $I_F = 5\text{ mA}$ | $t_{off}$ |      | 25   |      | $\mu\text{s}$ |  |

**TYPICAL CHARACTERISTICS**

$T_{amb} = 25\text{ }^{\circ}\text{C}$ , unless otherwise specified

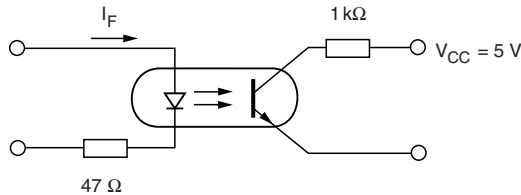

isfh615aa\_01

Fig. 1 - Switching Operation (with Saturation)

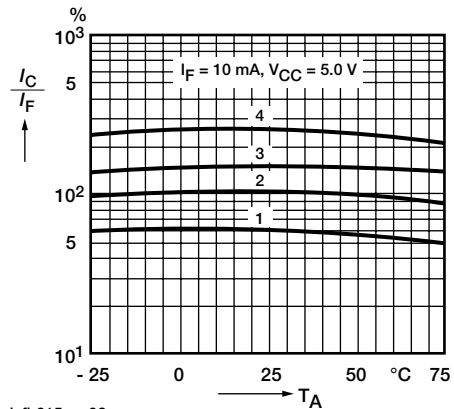

isfh615aa\_02

Fig. 2 - Current Transfer Ratio (Typ.) vs. Temperature

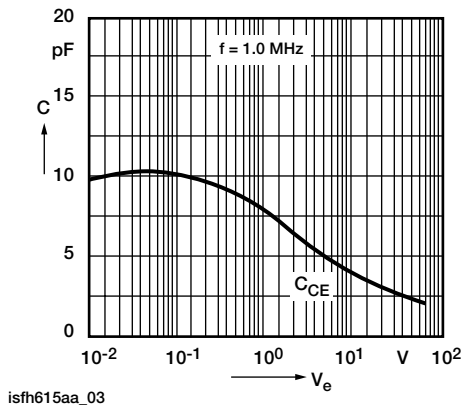

Fig. 3 - Transistor Capacitance (Typ.) vs. Collector Emitter Voltage



Fig. 6 - Permissible Pulse Handling Capability Forward Current vs. Pulse Width



Fig. 4 - Permissible Diode Forward Current vs. Ambient Temperature



Fig. 7 - Diode Forward Voltage (Typ.) vs. Forward Current

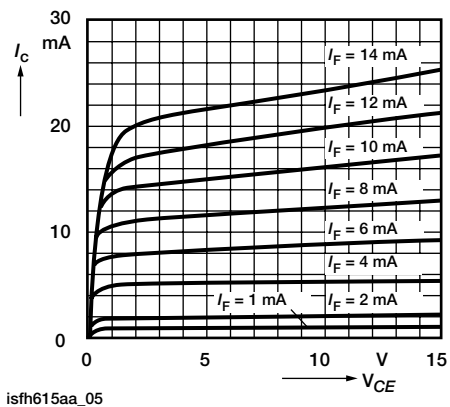

Fig. 5 - Output Characteristics (Typ.) Collector Current vs. Collector Emitter Voltage

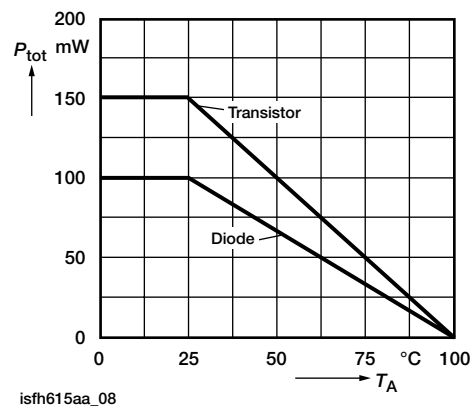

Fig. 8 - Permissible Power Dissipation vs. Temperature



# SFH615AA, SFH615AGB, SFH615AGR, SFH615ABM, SFH615ABL, SFH615AY, SFH615AB

Optocoupler, Phototransistor Output, Vishay Semiconductors  
High Reliability, 5300 V<sub>RMS</sub>

## PACKAGE DIMENSIONS in inches (millimeters)

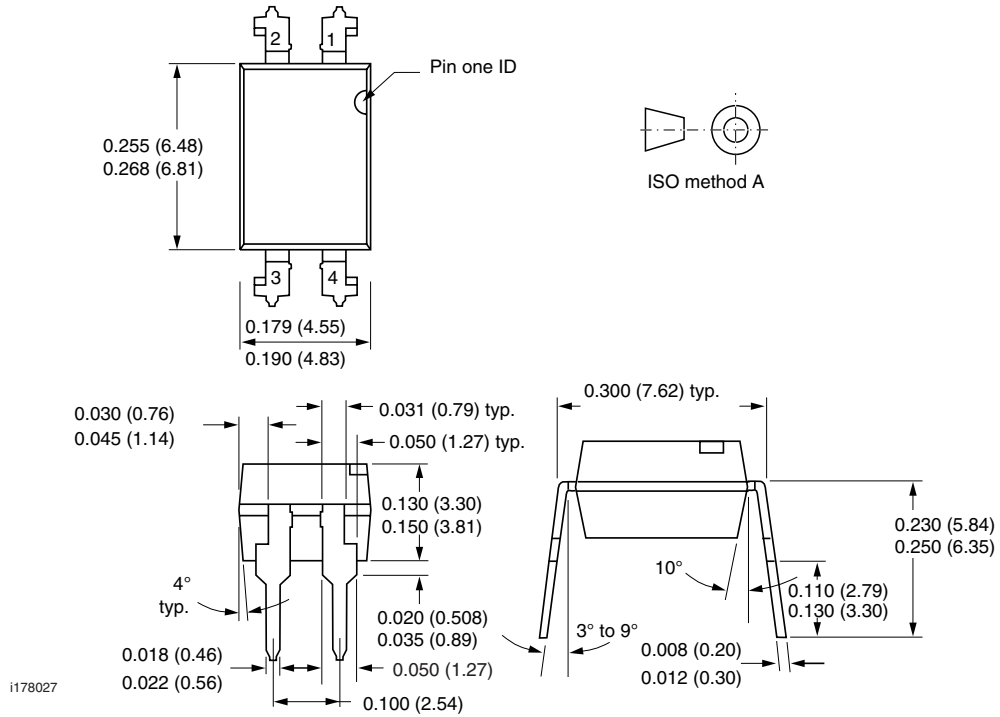

### Option 9

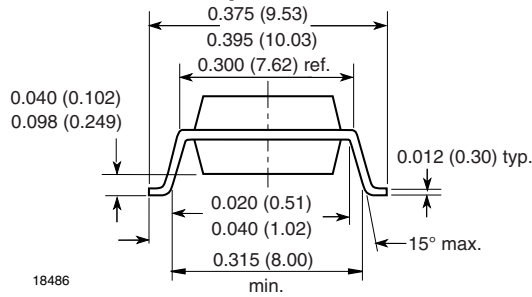



## **OZONE DEPLETING SUBSTANCES POLICY STATEMENT**

It is the policy of Vishay Semiconductor GmbH to

1. Meet all present and future national and international statutory requirements.
2. Regularly and continuously improve the performance of our products, processes, distribution and operating systems with respect to their impact on the health and safety of our employees and the public, as well as their impact on the environment.

It is particular concern to control or eliminate releases of those substances into the atmosphere which are known as ozone depleting substances (ODSs).

The Montreal Protocol (1987) and its London Amendments (1990) intend to severely restrict the use of ODSs and forbid their use within the next ten years. Various national and international initiatives are pressing for an earlier ban on these substances.

Vishay Semiconductor GmbH has been able to use its policy of continuous improvements to eliminate the use of ODSs listed in the following documents.

1. Annex A, B and list of transitional substances of the Montreal Protocol and the London Amendments respectively.
2. Class I and II ozone depleting substances in the Clean Air Act Amendments of 1990 by the Environmental Protection Agency (EPA) in the USA.
3. Council Decision 88/540/EEC and 91/690/EEC Annex A, B and C (transitional substances) respectively.

Vishay Semiconductor GmbH can certify that our semiconductors are not manufactured with ozone depleting substances and do not contain such substances.

We reserve the right to make changes to improve technical design  
and may do so without further notice.

Parameters can vary in different applications. All operating parameters must be validated for each customer application by the customer. Should the buyer use Vishay Semiconductors products for any unintended or unauthorized application, the buyer shall indemnify Vishay Semiconductors against all claims, costs, damages, and expenses, arising out of, directly or indirectly, any claim of personal damage, injury or death associated with such unintended or unauthorized use.

Vishay Semiconductor GmbH, P.O.B. 3535, D-74025 Heilbronn, Germany



## Disclaimer

All product specifications and data are subject to change without notice.

Vishay Intertechnology, Inc., its affiliates, agents, and employees, and all persons acting on its or their behalf (collectively, "Vishay"), disclaim any and all liability for any errors, inaccuracies or incompleteness contained herein or in any other disclosure relating to any product.

Vishay disclaims any and all liability arising out of the use or application of any product described herein or of any information provided herein to the maximum extent permitted by law. The product specifications do not expand or otherwise modify Vishay's terms and conditions of purchase, including but not limited to the warranty expressed therein, which apply to these products.

No license, express or implied, by estoppel or otherwise, to any intellectual property rights is granted by this document or by any conduct of Vishay.

The products shown herein are not designed for use in medical, life-saving, or life-sustaining applications unless otherwise expressly indicated. Customers using or selling Vishay products not expressly indicated for use in such applications do so entirely at their own risk and agree to fully indemnify Vishay for any damages arising or resulting from such use or sale. Please contact authorized Vishay personnel to obtain written terms and conditions regarding products designed for such applications.

Product names and markings noted herein may be trademarks of their respective owners.