

丸凸形

Round-Top View Type

φ 2.0mm Series

Type No. Lighting Color
 LN222RP Red
 LN322GP Green
 LN422YP Amber

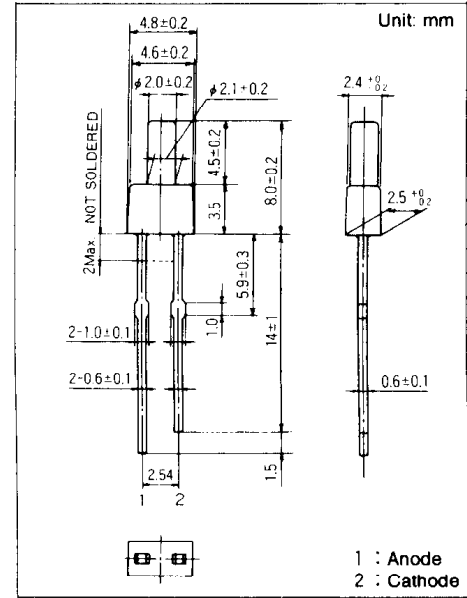

絶対最大定格 Absolute Maximum Ratings (Ta=25 °C)

Lighting Color	P _D (mW)	I _F (mA)	I _{FP} (mA)*	V _R (V)	To _{pr} (°C)	Tstg (°C)
Red	70	25	150	4	-25~+85	-30~+100
Green	90	30	150	4	-25~+85	-30~+100
Amber	90	30	150	4	-25~+85	-30~+100

* I_{FP}の条件は、duty 10%, Pulse width 1 msec. The condition of I_{FP} is duty 10%, Pulse width 1 msec

電気的光学的特性 Electro-Optical Characteristics (Ta=25 °C)

Type No.	Lighting Color	Lens Color	I _O			V _F		λ _p	Δλ	I _F	I _R	
			Typ.	Min.	I _F	Typ.	Max.				Max.	V _R
LN222RP	Red	Red Diffused	1.0	0.4	15	2.2	2.8	700	100	20	5	4
LN322GP	Green	Green Diffused	1.0	0.4	20	2.2	2.8	565	30	20	10	4
LN422YP	Amber	Amber Diffused	2.5	1.2	20	2.2	2.8	590	30	20	10	4
Unit	---	---	mcd	mcd	mA	V	V	nm	nm	mA	μA	V

