

UNCONTROLLED DOCUMENT

* PATENT PENDING

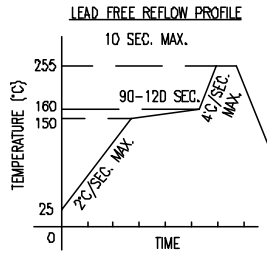

TOTAL TIME ABOVE 220°C IS 60 SECONDS MAX.

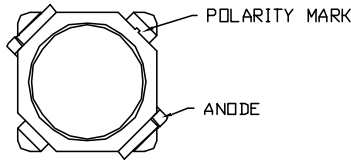
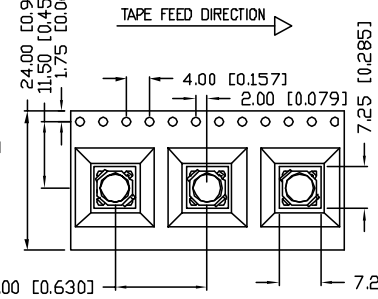
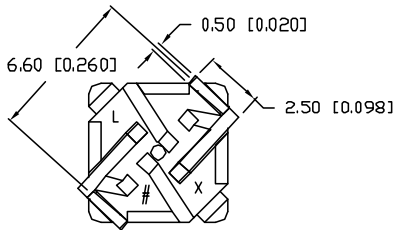
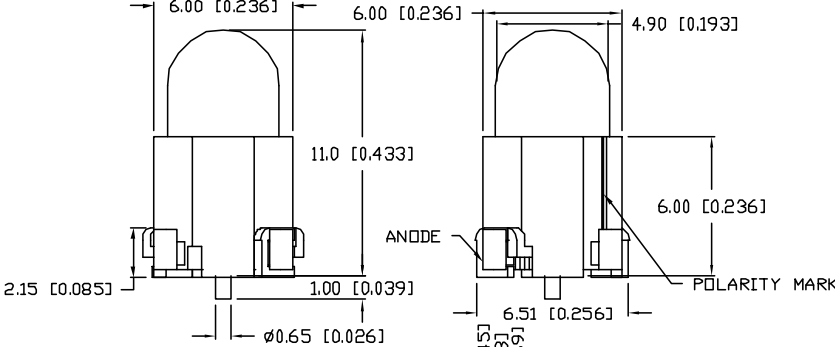

NOTE:
1. CATHODE IS ORIENTED TOWARDS THE TAPE SPROCKET HOLES.

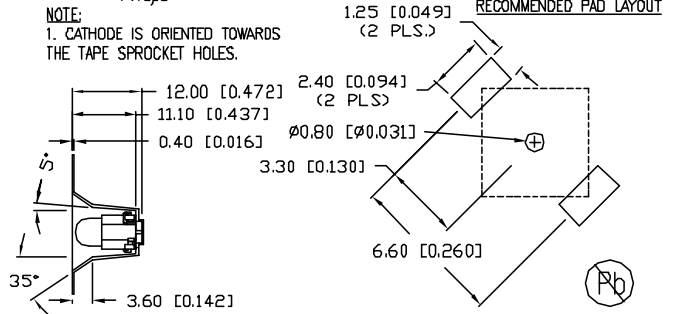

PART NUMBER
SML-H1505SOC-TR

REV.

ELECTRO-OPTICAL CHARACTERISTICS $T_A=25^\circ\text{C}$ $I_f=20\text{mA}$					
PARAMETER	MIN	TYP	MAX	UNITS	TEST COND
PEAK WAVELENGTH		610		nm	
FORWARD VOLTAGE		2.1	2.6	V_f	
REVERSE VOLTAGE	5.0			V_r	$I_f=100\mu\text{A}$
AXIAL INTENSITY		1500		mcd	$I_f=20\text{mA}$
VIEWING ANGLE		68		$2x$ theta	
EMITTED COLOR:	ORANGE				
EPOXY LENS FINISH:	WATER CLEAR				

LIMITS OF SAFE OPERATION AT 25°C PER DIE		
PARAMETER	MAX	UNITS
PEAK FORWARD CURRENT*	100	mA
STEADY CURRENT	30	mA
POWER DISSIPATION	90	mW
DERATE FROM 25°C	-1.2	mW/°C
OPERATING TEMP.	-30 TO +80	°C
STORAGE TEMP.	-40 TO +100	°C
SOLDERING TEMP.	+260	°C
2.0mm FROM BODY		5 SEC. MAX
* $T < 10\mu\text{s}$		

*UNLESS OTHERWISE SPECIFIED TOLERANCES PER DECIMAL PRECISION ARE: X=±1 (±0.039), XX=±0.5 (±0.020), XXX=±0.25 (±0.010), XXXX=±0.127 (±0.005). LEAD SIZE=±0.05 (±0.002), LEAD LENGTH=±0.75 (±0.030). MIN= -0.000. DECIMAL PRECISION MAX.= +0.000 DECIMAL PRECISION

UNCONTROLLED DOCUMENT

REV. PART NUMBER
SML-H1505SOC-TR

5mm SURFACE MOUNTED DOME LED,
610nm SUPER ORANGE LED, WATER CLEAR.

CONFIDENTIAL INFORMATION
THE INFORMATION CONTAINED IN THIS DOCUMENT IS THE PROPERTY OF LUMEX INC. EXCEPT AS SPECIFICALLY AUTHORIZED IN WRITING BY LUMEX INC., THE HOLDER OF THIS DOCUMENT SHALL KEEP ALL INFORMATION CONTAINED HEREIN CONFIDENTIAL AND SHALL PROTECT SAME IN WHOLE OR IN PART FROM DISCLOSURE AND DISSEMINATION TO ALL THIRD PARTIES.

RELIABILITY NOTE
OUR MANY YEARS OF EXPERIENCE DATA ACCUMULATION INDICATE THAT SOLDER HEAT IS A MAJOR CAUSE OF EARLY AND FUTURE FAILURE. PLEASE PAY ATTENTION TO YOUR SOLDERING PROCESS.



290 E. HELEN ROAD
PALATINE, IL 60067-6976
PHONE: +1.847.359.2790
US WEB: www.lumex.com
TW WEB: www.lumex.com.tw

DRAWN BY: JUN
CHECKED BY:
APPROVED BY:
DATE: 03.12.08
PAGE: 1 OF 1
SCALE: N/A