

### PRELIMINARY SPEC

Part Number: AAAF5060PBESEEVGEC



**ATTENTION**  
OBSERVE PRECAUTIONS  
FOR HANDLING  
ELECTROSTATIC  
DISCHARGE  
SENSITIVE  
DEVICES

Blue  
Hyper Orange  
Green

### Features

- CHIPS CAN BE CONTROLLED SEPARATELY.
- SUITABLE FOR ALL SMT ASSEMBLY AND SOLDER PROCESS.
- AVAILABLE ON TAPE AND REEL.
- PACKAGE: 500PCS / REEL.
- MOISTURE SENSITIVITY LEVEL : LEVEL 4.
- RoHS COMPLIANT.

### Description

The Blue source color devices are made with InGaN on SiC Light Emitting Diode.

The Hyper Orange source color devices are made with InGaAlP on GaAs substrate Light Emitting Diode.

The Green source color devices are made with InGaN on SiC Light Emitting Diode.

Static electricity and surge damage the LEDs.

It is recommended to use a wrist band or anti-electrostatic glove when handling the LEDs.

All devices, equipment and machinery must be electrically grounded.

### Package Dimensions

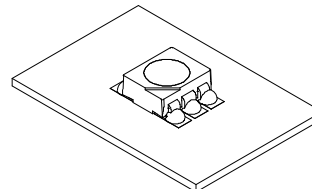
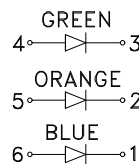
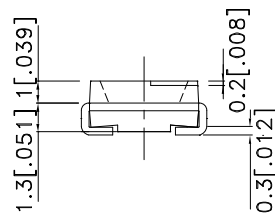
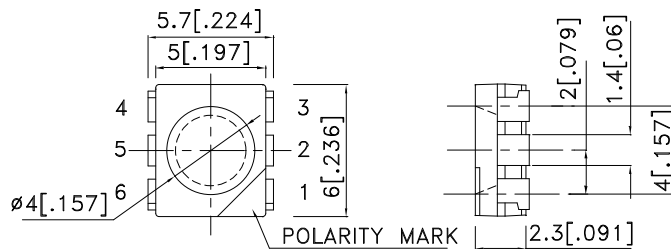

#### Notes:

1. All dimensions are in millimeters (inches).
2. Tolerance is  $\pm 0.25(0.01)$  unless otherwise noted.
3. Specifications are subject to change without notice.
4. The device has a single mounting surface. The device must be mounted according to the specifications.



## Selection Guide

Part No.	Dice	Lens Type	Iv (mcd) [2] @ 30mA *50mA		Viewing Angle [1]
			Min.	Typ.	2θ1/2
AAAF5060PBESEEVGEC	Blue (InGaN)	WATER CLEAR	110	250	100°
	Hyper Orange (InGaAlP)		*650	*1000	
	Green (InGaN)		280	600	

Notes:

1. θ1/2 is the angle from optical centerline where the luminous intensity is 1/2 the optical centerline value.
2. \*Luminous intensity with asterisk is measured at 50mA; Luminous intensity/ luminous Flux: +/-15%.

## Electrical / Optical Characteristics at TA=25°C

Symbol	Parameter	Device	Typ.	Max.	Units	Test Conditions
λpeak	Peak Wavelength	Blue Hyper Orange Green	468 630 520		nm	If=20mA
λD [1]	Dominant Wavelength	Blue Hyper Orange Green	470 621 525		nm	If=20mA
Δλ1/2	Spectral Line Half-width	Blue Hyper Orange Green	21 20 35		nm	If=20mA
C	Capacitance	Blue Hyper Orange Green	100 25 100		pF	Vf=0V;f=1MHz
Vf [2]	Forward Voltage	Blue Hyper Orange Green	3.2 2 3.2	4 2.5 4	V	If=20mA
IR	Reverse Current	Blue Hyper Orange Green		10 10 10	uA	VR=5V

Notes:

1. Wavelength: +/-1nm.
2. Forward Voltage: +/-0.1V.

## Absolute Maximum Ratings at TA=25°C

Parameter	Blue	Hyper Orange	Green	Units
Power dissipation[2]	350			mW
DC Forward Current	30	50	30	mA
Peak Forward Current [1]	100	195	100	mA
Reverse Voltage	5			V
Operating Temperature	-40°C To +85°C			
Storage Temperature	-40°C To +85°C			

Notes:

1. 1/10 Duty Cycle, 0.1ms Pulse Width.
2. Within 350mW at all chips are lightened.

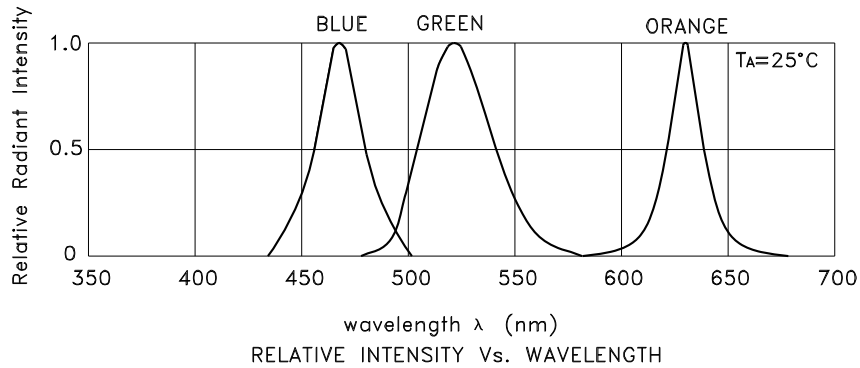

## AAAF5060PBESEEVGEC Blue

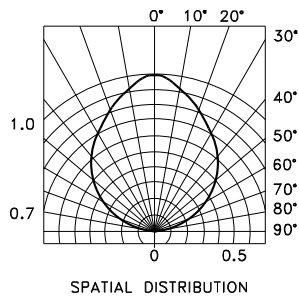
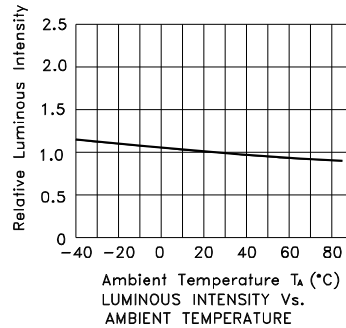
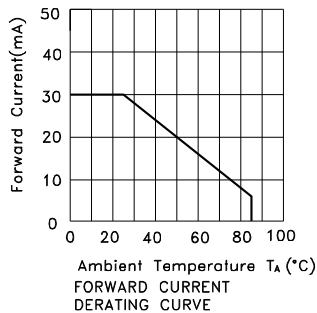
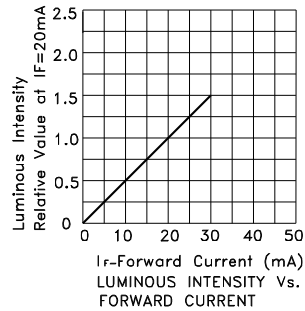
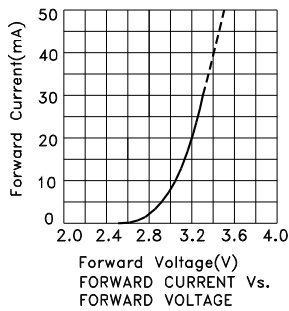

# Kingbright

## Hyper Orange

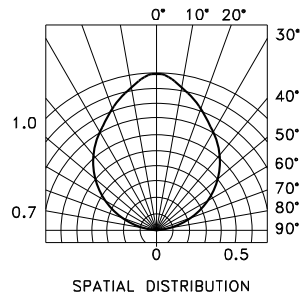
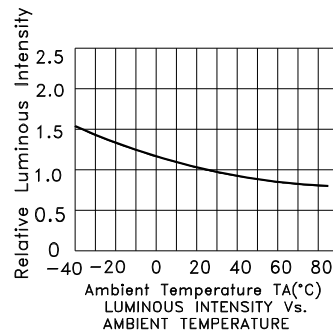
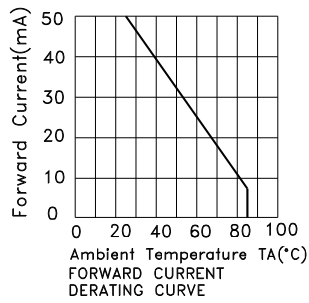
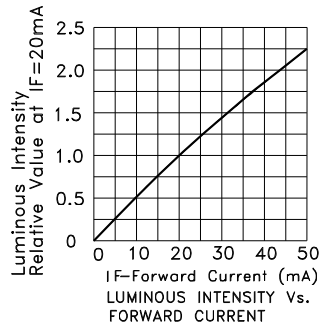
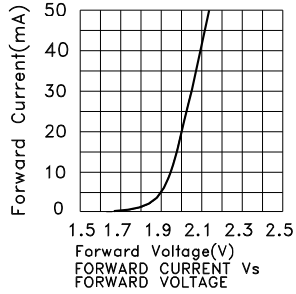

## Green

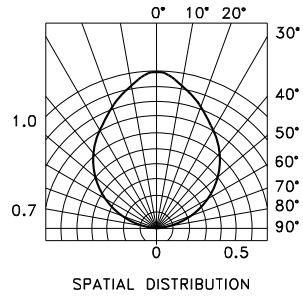
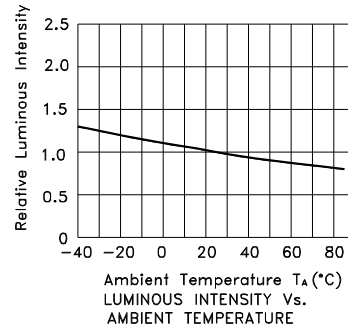
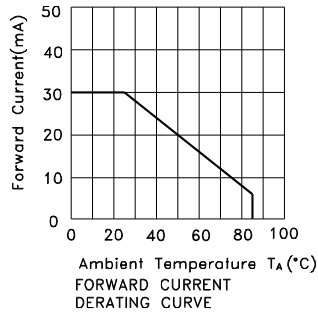
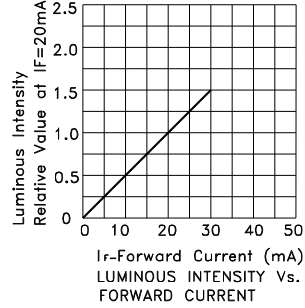
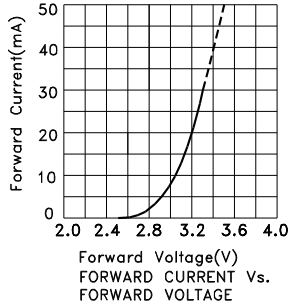

## AAAF5060PBESEEVGEC

Reflow Soldering Profile For Lead-free SMT Process.

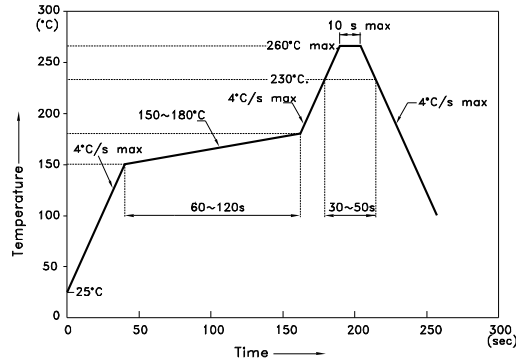

**NOTES:**

1. We recommend the reflow temperature 245°C(+/-5°C). The maximum soldering temperature should be limited to 260°C.
2. Don't cause stress to the epoxy resin while it is exposed to high temperature.
3. Number of reflow process shall be 2 times or less.

### Recommended Soldering Pattern (Units : mm; Tolerance: ± 0.1)

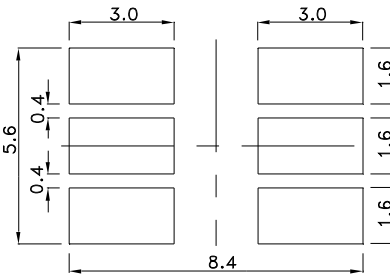

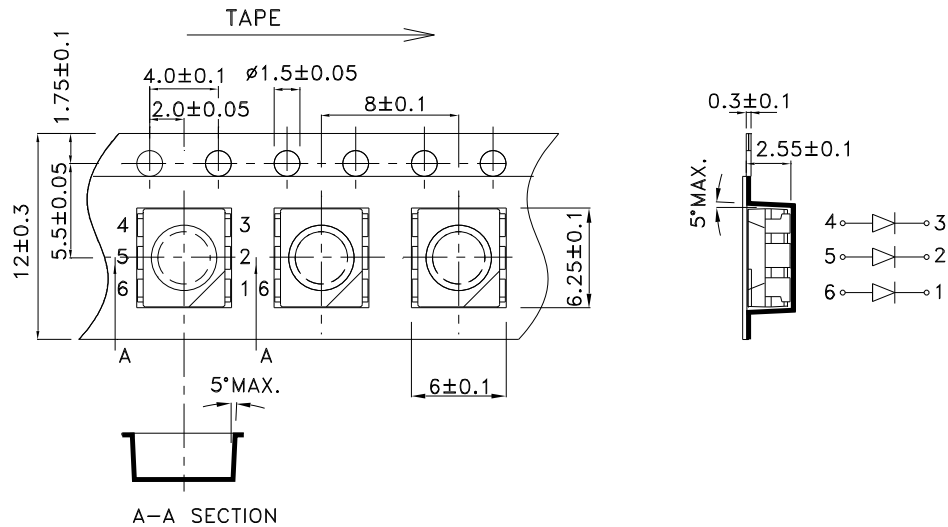

### Tape Specifications (Units : mm)

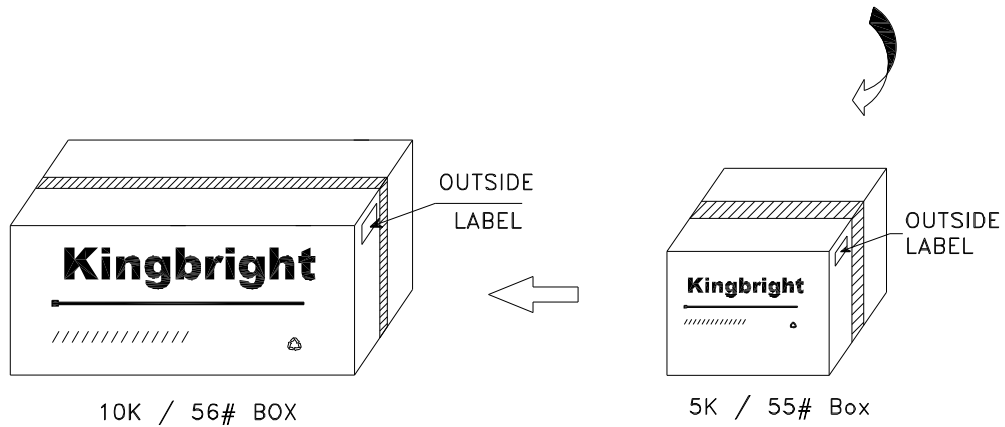
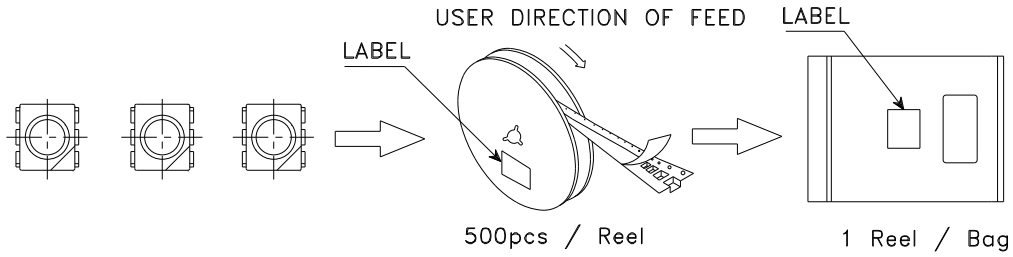

**PACKING & LABEL SPECIFICATIONS**

**AAAF5060PBESEEVGEC**



<b>Kingbright</b>	
P/NO: AAAF5060xxx	
QTY: 500 pcs	Q.C. <span style="border: 1px solid black; border-radius: 50%; padding: 2px;">Q C xx xx xxxx PASSED</span>
S/N: XXXX	
CODE: XXX	
LOT NO:	
 xxxxxxxxxxxxxxxxxxxxxxxx	
RoHS Compliant	