

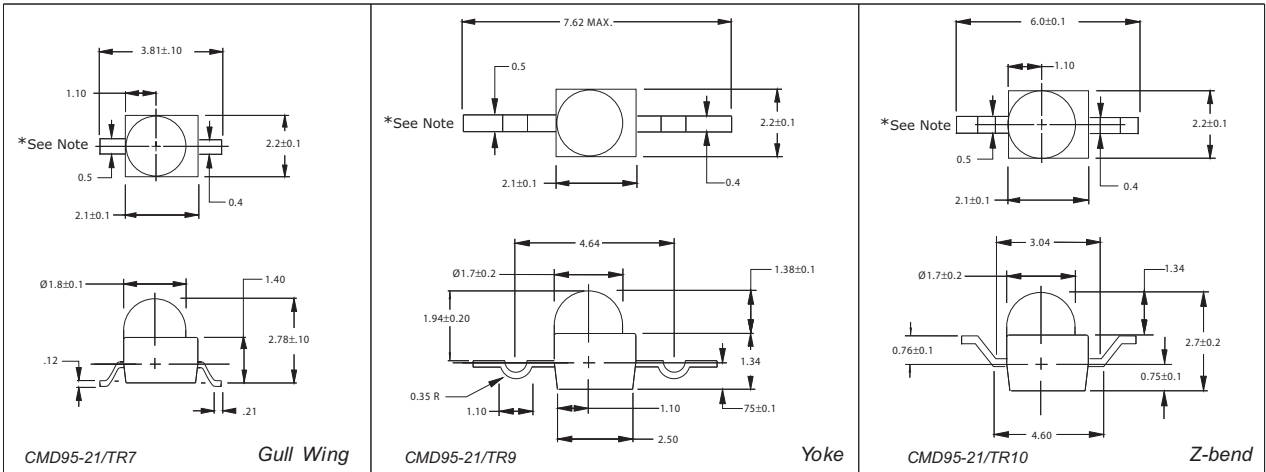

CMD95-21/TR7, TR9, TR10 Series SMT LEDs

DESCRIPTION AND FEATURES



Surface Mount Technology

- Tape and reel packaged for high-speed autoinsertion.
- Convection and vapor-phase reflow compatible.
- Compact form enables high density placement.
- 1000 pieces per reel.
- Gull wing, Yoke or Z-bend lead configurations.

Exceptional Reliability

- Stringent process controls assure quality.
- Extensive qualification testing to meet strictest requirements.
- Designed to permit easy post-reflow solder joint inspection.

Leading Edge LED Optoelectronic Performance

- Consistent high brightness.

All dimensions in mm.

*Cathode for VGC/VYC/VRC
Anode for SRC

ELECTRO-OPTICAL CHARACTERISTICS

Part Number	Emitted Color	Lens Color	Luminous Intensity		Forward Voltage		Viewing Angle (degrees)	Peak Wavelength (nm)	Package Type
			Min. (mcd)	Typ. (mcd)	Typ. (V)	Max. (V)			
CMD95-21VGC/TR7	Green	Clear	11.5	19.5	2.1	2.8	25	570	Single
CMD95-21VYC/TR7	Yellow	Clear	16.0	25.0	2.0	2.8	25	585	Single
CMD95-21VRC/TR7	Red	Clear	16.0	25.0	2.0	2.8	25	640	Single
CMD95-21SRC/TR7	Red	Clear	60.0	100.0	1.7	2.4	25	660	Single
CMD95-21VGC/TR9	Green	Clear	11.5	19.5	2.1	2.8	25	570	Single
CMD95-21VYC/TR9	Yellow	Clear	16.0	25.0	2.0	2.8	25	585	Single
CMD95-21VRC/TR9	Red	Clear	16.0	25.0	2.0	2.8	25	640	Single
CMD95-21SRC/TR9	Red	Clear	60.0	100.0	1.7	2.4	25	660	Single
CMD95-21VGC/TR10	Green	Clear	11.5	19.5	2.1	2.8	25	570	Single
CMD95-21VYC/TR10	Yellow	Clear	16.0	25.0	2.0	2.8	25	585	Single
CMD95-21VRC/TR10	Red	Clear	16.0	25.0	2.0	2.8	25	640	Single
CMD95-21SRC/TR10	Red	Clear	60.0	100.0	1.7	2.4	25	660	Single

ABSOLUTE MAXIMUM RATINGS

	Green	Yellow	Red	Units
Power Dissipation.....	105	105	100	mW
Storage.....	-40 to +100	-40 to +100	-40 to +100	°C
Operating Temperature.....	-40 to +85	-40 to +85	-40 to +85	°C
Peak Forward Current (1µs @ 10% duty cycle).....	150	150	150	mA
Reverse Voltage (IR=100µA).....	5.0	5.0	5.0	V
Lead Solder Time @ 260°C.....	5	5	5	Seconds
Forward Current.....	25	30	30	mA

147 Central Avenue
Hackensack, NJ 07601
Phone: (201) 489-8989
Fax: (201) 489-6911

18703 Dix Toledo Road
Brownstown, MI 48193

Saret Zone Franca, Edificio B
Alajuela Costa Rica

E-mail:sales@chml.com • Web Site: www.chml.com

Chicago Miniature Lighting, LLC reserves the right to make specification revisions that enhance the design and/or performance of the product