

UNCONTROLLED DOCUMENT

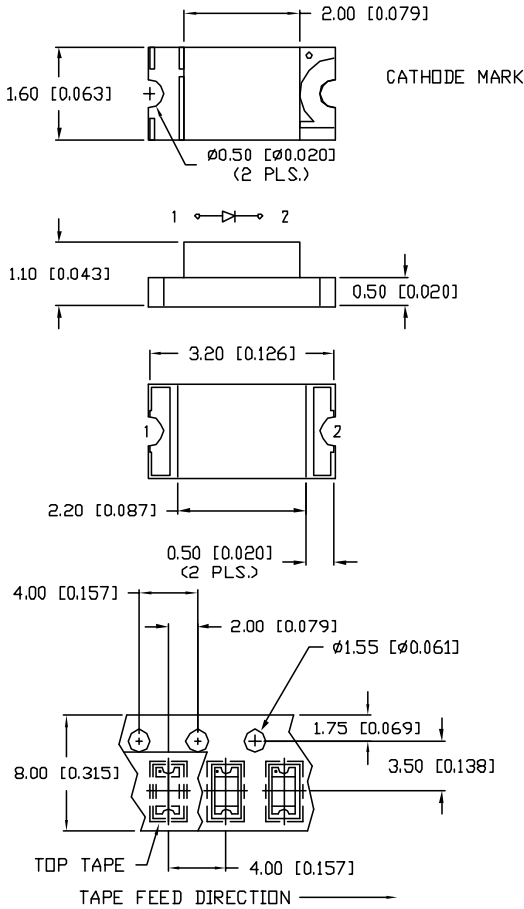

CAUTION: STATIC SENSITIVE DEVICE
FOLLOW PROPER E.S.D. HANDLING PROCEDURES
WHEN WORKING WITH THIS PART.

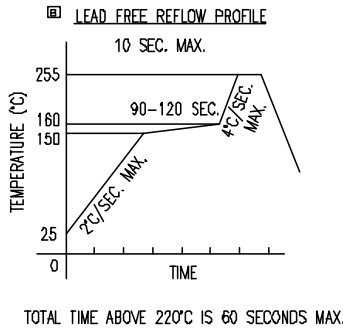
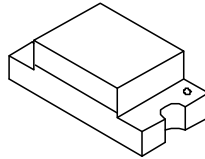

RECOMMENDED SOLDER PAD LAYOUT

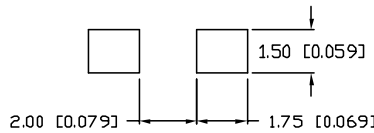

*UNLESS OTHERWISE SPECIFIED TOLERANCES PER DECIMAL PRECISION ARE: X=±1 (±0.039), X.X=±0.5 (±0.020), X.XX=±0.25 (±0.010), X.XXX=±0.127 (±0.005). LEAD SIZE=±0.05 (0.002), LEAD LENGTH=±0.75 (±0.030), MIN.=^{+DECIMAL PRECISION}_{-0.00}, MAX.=^{+0.00}_{-DECIMAL PRECISION}

PART NUMBER
SML-LX1206UWW-TR

REV.
B

REV.	E.C.N. NUMBER AND REVISION COMMENTS	DATE
A	E.C.N. #10967.	3.14.03
B	E.C.N. #11148.	1.20.05

ELECTRO-OPTICAL CHARACTERISTICS T_A=25°C

PARAMETER	SYMBOL	MIN	TYP	MAX	UNITS	TEST COND
PEAK WAVELENGTH			550		nm	
FORWARD VOLTAGE	V _f	3.5	4.0		V	I _f =20mA
REVERSE VOLTAGE	V _r	5			V	I _r =10μA
AXIAL INTENSITY(*1)	I _v		90		mcd	I _f =20mA
CHROMATICITY	X		0.31			
COORDINATES(*2)	Y		0.33			I _f =20mA
VIEWING ANGLE			140		2x theta	

EMITTED COLOR: WHITE

EPOXY LENS FINISH: YELLOW DIFFUSED

*1. AXIAL INTENSITY TESTING CONDITION: 550nm WAVELENGTH.

*2. THE ICI STANDARD COLORIMETRIC SYSTEM.

LIMITS OF SAFE OPERATION AT 25°C

PARAMETER	MAX	UNITS
PEAK FORWARD CURRENT*	80	mA
STEADY CURRENT	30	mA
POWER DISSIPATION	70	mW
DERATE FROM 25°C	-1.2	mW/°C
OPERATING TEMP.	-25 TO +85	°C
STORAGE TEMP.	-25 TO +85	°C

NOTES:

- THE POLARITY MARK IS ORIENTED TOWARDS THE TAPE SPROCKET HOLE.

CAUTION: MOISTURE SENSITIVE DEVICE
PER JEDEC LEVEL 4 STANDARDS

UNCONTROLLED DOCUMENT

REV. B PART NUMBER SML-LX1206UWW-TR

3.2mm x 1.6mm PCB SURFACE MOUNT LED,
ULTRA WHITE LED,
YELLOW DIFFUSED LENS, TAPE AND REEL.

CONFIDENTIAL INFORMATION
THE INFORMATION CONTAINED IN THIS DOCUMENT IS THE PROPERTY OF LUMEX INC. EXCEPT AS SPECIFICALLY AUTHORIZED IN WRITING BY LUMEX INC., THE HOLDER OF THIS DOCUMENT SHALL KEEP ALL INFORMATION CONTAINED HEREIN CONFIDENTIAL AND SHALL PROTECT SAME IN WHOLE OR IN PART FROM DISCLOSURE AND DISSEMINATION TO ALL THIRD PARTIES.

RELIABILITY NOTE
OUR MANY YEARS OF EXPERIENCE DATA ACCUMULATION INDICATE THAT SOLDER HEAT IS A MAJOR CAUSE OF EARLY AND FUTURE FAILURE. PLEASE PAY ATTENTION TO YOUR SOLDERING PROCESS.



290 E. HELEN ROAD
PALATINE, IL 60067-6976
PHONE: +1.847.359.2790
US WEB: www.lumex.com
TW WEB: www.lumex.com.tw

DRAWN BY: CT CHECKED BY: APPROVED BY: DATE: 2.10.03
PAGE: 1 OF 1
SCALE: N/A