

BI-COLOR OPERATING CHARACTERISTICS AT T _a = 25 °C AMBIENT													
DIALIGHT P/N	COLOR	I _f (mA)	FORWARD VOLTAGE (V)		LUMINOUS INTENSITY (mcd)		REVERSE CURRENT (μA)		PEAK WAVELENGTH (nm)		DOMINANT WAVELENGTH (nm)		
			TYP.	MAX.	MIN.	TYP.	MAX.	TYP.	MAX.	TYP.	MIN.	TYP.	MAX.
597-7701-202F	SUPER RED GREEN	10	2.0	2.5	4.5	11.3	18.0	.01	10	635	622	628	634
597-7701-207F	SUPER RED GREEN	10	2.0	2.5	4.5	11.3	18.0	.01	10	635	622	628	634

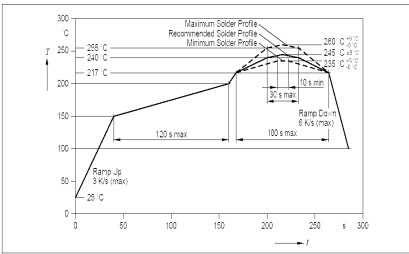

RoHS COMPLIANT REFLOW PROFILE

REV	ECN NO	REVISIONS	DRN	CKD	APP	DATE
A		NEW RELEASE	TWC			

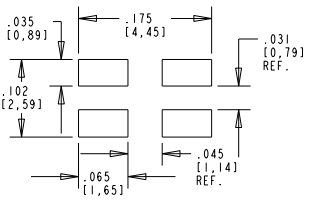
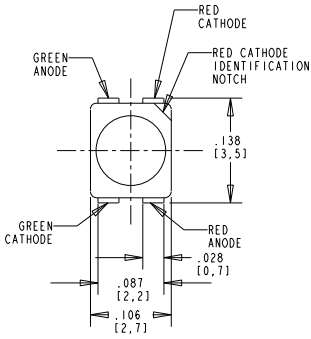
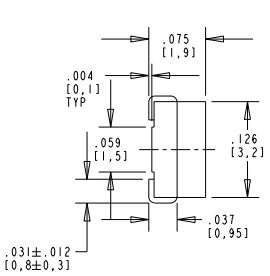

RECOMMENDED SOLDER PAD LAYOUT

- NOTE:
- EPOXY COLOR: WATER CLEAR.
 - DIE: GaP FOR GREEN AND GaAsP/GaP FOR RED.
 - LEAD FINISH: 100% TIN (Sn) OVER NICKEL (Ni) UNDERPLATING ON COPPER ALLOY (Cu).
 - SOLDER ADHERANCE: BOTH LEADS PER MIL-STD-202E, METHOD 208C.
 - PART TAPED AND REELED PER EIA-RS-481-1.
 - SUFFIX -202F FOR 20 PCS ON A SAMPLE TAPE STRIP.
 - SUFFIX -207F FOR 7" DIAMETER REEL. PACKAGED 2000 PCS PER REEL.
 - LABELING FOR REEL AND OUTSIDE OF ALUMINUM FOIL BAG: DIALIGHT P/N, R/G BICOLOR, QUANTITY PER REEL, DATE CODE, INTENSITY BIN CODE, LOT NUMBER AND COUNTRY OF ORIGIN.
 - DIALIGHT P/N: 597-7701-202F, 597-7701-207F.
 - TAPE AND REEL LEDS MAY REQUIRE RE-TAPING AFTER TWELVE MONTHS.

RoHS Compliant 597-7701-20XF Surface Mount Bi-color CBI

Part Numbers with the "F" suffix ending are RoHS Compliant.
 Example: 597-7701-207F
 Reel and bag packaging are marked with "RoHS Compliant" label or equivalent markings. These parts can be used with RoHS reflow profile. Parts can be wave soldered, dip soldered or hand soldered using typical lead-free soldering process with max 260°C temp. for 5 sec.

ABSOLUTE MAXIMUM RATING AT 25°C AMBIENT	597-7701-20XF		UNITS
	202F	207F	
POWER CONSUMPTION	95		mW
CONTINUOUS FORWARD CURRENT	30		mA
REVERSE VOLTAGE	5		V
OPERATING TEMPERATURE	-40 TO +100		°C
STORAGE TEMPERATURE			

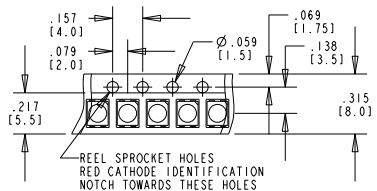

TAPE & REEL CONFIGURATION

THIS DRAWING AND THE CONTENTS HEREIN ARE CONFIDENTIAL AND THE SOLE PROPERTY OF DIALIGHT. REPRODUCTION OF THIS DRAWING OR CONSTRUCTION OF ANY PARTS WITHIN THIS DRAWING ARE FORBIDDEN WITHOUT THE WRITTEN CONSENT OF DIALIGHT.		
SCALE: DRAWING SCALE ALL DIM'S IN: INCHES (MM)	DRAWING NUMBER C-17319	REV A
TOLERANCES: UNLESS OTHERWISE SPECIFIED FRACTIONS: ±1/64 DECIMALS (.xxx): ±.01 DECIMALS (.xxxx): ±.005 DECIMALS (.xxxxx): ±.0005 ANGLES: ±1°	TITLE R/G BI-COLOR MATERIAL ROHS COMPLIANT	
FINISH:	Dialight 1501 ROUTE 34 SOUTH FARMINGDALE, NJ 07727	
FSCM 83330	SHEET 1 OF 1 FAMILY TABLE:	