

UNCONTROLLED DOCUMENT

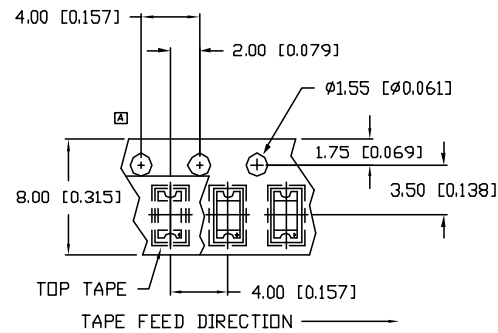

LEAD FREE REFLOW PROFILE

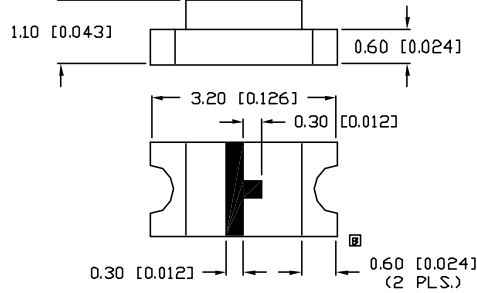
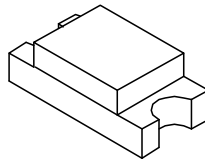
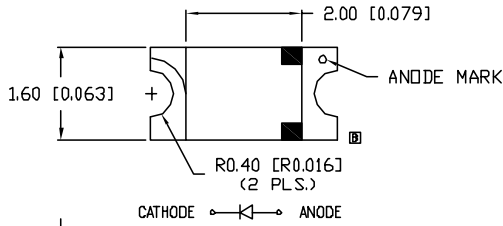
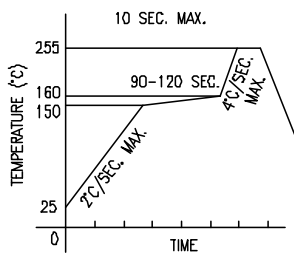

TOTAL TIME ABOVE 220°C IS 60 SECONDS MAX.

RECOMMENDED SOLDER PAD LAYOUT

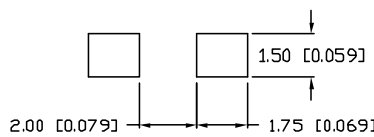

\*UNLESS OTHERWISE SPECIFIED TOLERANCES PER DECIMAL PRECISION ARE: X=±1 (±0.039), XX=±0.5 (±0.020), XXX=±0.25 (±0.010), XXXX=±0.127 (±0.005). LEAD SIZE=±0.05 (0.002), LEAD LENGTH=±0.75 (±0.030), MIN= -0.00 DECIMAL PRECISION, MAX.= +0.00 DECIMAL PRECISION

PART NUMBER		REV.
SML-LX1206SRW-TR		E
REV.	E.C.N. NUMBER AND REVISION COMMENTS	DATE
A	E.C.N. #10644. & REDRAWN IN 3D.	7.18.00
B	E.C.N. #10814.	12.3.01
C	E.C.N. #10967.	3.14.03
D	E.C.N. #11065.	12.9.03
E	E.C.N. #11148.	1.20.05

ELECTRO-OPTICAL CHARACTERISTICS T <sub>A</sub> =25°C I <sub>F</sub> =20mA					
PARAMETER	MIN	TYP	MAX	UNITS	TEST COND
PEAK WAVELENGTH		660		nm	
FORWARD VOLTAGE		1.8	2.2	V <sub>F</sub>	
REVERSE VOLTAGE	4.0			V <sub>R</sub>	I <sub>F</sub> =100µA
AXIAL INTENSITY		15		mcd	I <sub>F</sub> =20mA
VIEWING ANGLE		160		2x theta	
EMITTED COLOR:	RED				
EPOXY LENS FINISH:	MILKY WHITE DIFFUSED				

LIMITS OF SAFE OPERATION AT 25°C

PARAMETER	MAX	UNITS
PEAK FORWARD CURRENT*	100	mA
STEADY CURRENT	30	mA
POWER DISSIPATION	80	mW
DERATE FROM 25°C	-1.2	mW/°C
OPERATING TEMP.	-25 TO +85	°C
STORAGE TEMP.	-30 TO +85	°C

NOTES:

1. THE CATHODE IS ORIENTED TOWARDS THE TAPE SPROCKET HOLE.

CAUTION: MOISTURE SENSITIVE DEVICE PER JEDEC LEVEL 4 STANDARDS

UNCONTROLLED DOCUMENT

REV. E	PART NUMBER SML-LX1206SRW-TR	<p>CONFIDENTIAL INFORMATION</p> <p>THE INFORMATION CONTAINED IN THIS DOCUMENT IS THE PROPERTY OF LUMEX INC. EXCEPT AS SPECIFICALLY AUTHORIZED IN WRITING BY LUMEX INC., THE HOLDER OF THIS DOCUMENT SHALL KEEP ALL INFORMATION CONTAINED HEREIN CONFIDENTIAL AND SHALL PROTECT SAME IN WHOLE OR IN PART FROM DISCLOSURE AND DISSEMINATION TO ALL THIRD PARTIES.</p> <p>RELIABILITY NOTE</p> <p>OUR MANY YEARS OF EXPERIENCE DATA ACCUMULATION INDICATE THAT SOLDER HEAT IS A MAJOR CAUSE OF EARLY AND FUTURE FAILURE. PLEASE PAY ATTENTION TO YOUR SOLDERING PROCESS.</p>	<p>290 E. HELEN ROAD PALATINE, IL 60067-6976 PHONE: +1.847.359.2790 US WEB: www.lumex.com TW WEB: www.lumex.com.tw</p>
3.2mm x 1.6mm PCB SURFACE MOUNT LED, 660nm SUPER RED, LED, MILKY WHITE DIFFUSED LENS, TAPE AND REEL.		<p>DRAWN BY: BC</p> <p>CHECKED BY:</p> <p>APPROVED BY:</p>	<p>DATE: 6.30.98</p> <p>PAGE: 1 OF 1</p> <p>SCALE: N/A</p>