

Approved	Checked	Designed	DEVELOPMENT SPECIFICATION				
		<i>K. Ohtani</i>	P/N : LN1371SGTRP				
TYPE		Green Light Emitting Diode					
APPLICATION		Indicators					
MATERIAL		GaP					
OUTLINE		Attached					
ABSOLUTE MAXIMUM RATINGS		P	※ I <sub>FP</sub>	I <sub>FDC</sub>	V <sub>R</sub>	Topr	Tstg
		30	50	10	4	-25~+85	-30~+100
		mW	mA	mA	V	°C	°C
CONDITION		T <sub>a</sub> = 25 ± 3 °C					
Test Specification							
Item	Symbol	Condition	Typ	Limit		Unit	
				Min	Max		
Forward Voltage	V <sub>F</sub>	I <sub>F</sub> = 5 mA	1.9		2.4	V	
Reverse Leakage Current	I <sub>R</sub>	V <sub>R</sub> = 4 V			10	μA	
Luminous Intensity	I <sub>O</sub>	I <sub>F</sub> = 5 mA · DC	2.0	0.7		mcd	
Peak Emission Wavelength	λ <sub>p</sub>	I <sub>F</sub> = 5 mA · DC	565			nm	
Spectral Line Half Width	Δλ	I <sub>F</sub> = 5 mA · DC	30			nm	
<p>※ · The Condition of I<sub>FP</sub> is duty 10 %, Pulse width 1 ms</p> <p>· Please contact the Panasonic local office if you design at low current (below 0.5mA DC) or pulse current operation and have any questions.</p> <p>NOTE</p> <ol style="list-style-type: none"> <li>1. Compositions of the lead ... Cu/Ni/Au plating</li> <li>2. Soldering conditions. Refer to Handling note.</li> <li>3. Care should be taken that soldering is done within 3-days after opening the dry package and reel.</li> <li>4. Package: Light green diffusion type.</li> <li>5. Circuit to operate LED.</li> </ol>							
						<p>(A) Recommended circuit.</p> <p>(B) The difference of brightness between the LED could be found due to the V<sub>F</sub> characteristics of each LED.</p>	
Oct. 27. 2001							

*K. Otsu*

P/N: LN1371SGTRP

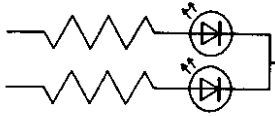
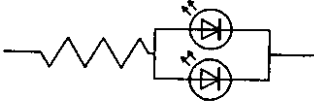
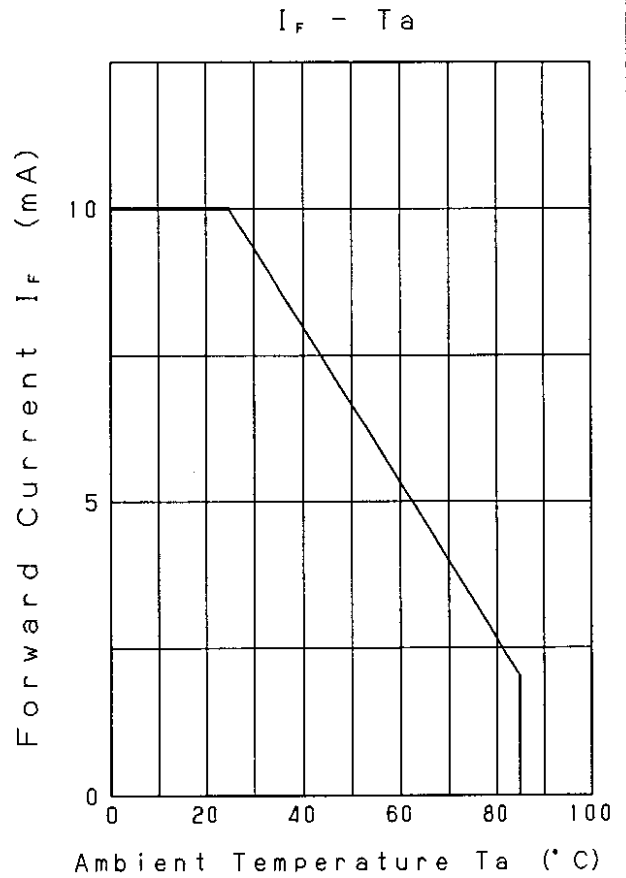
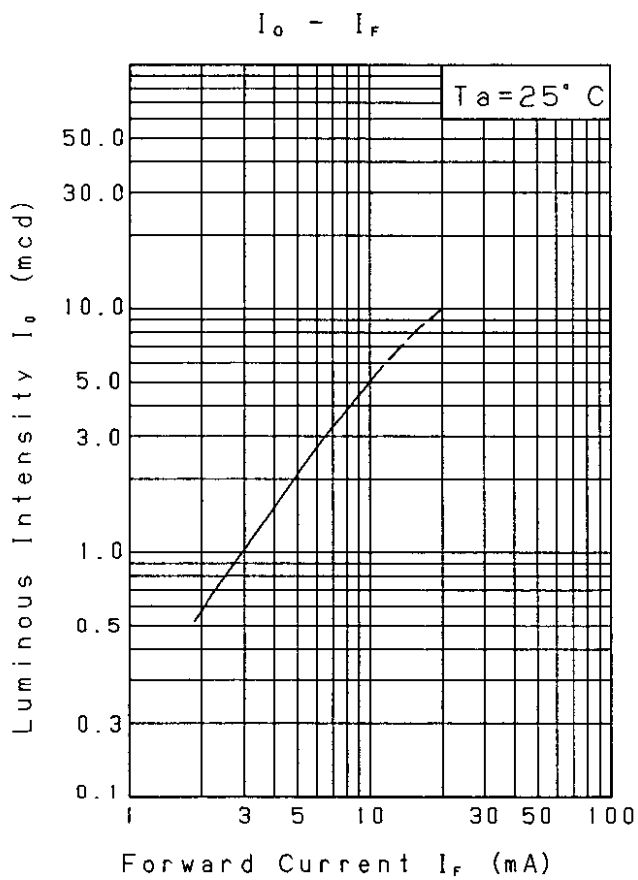
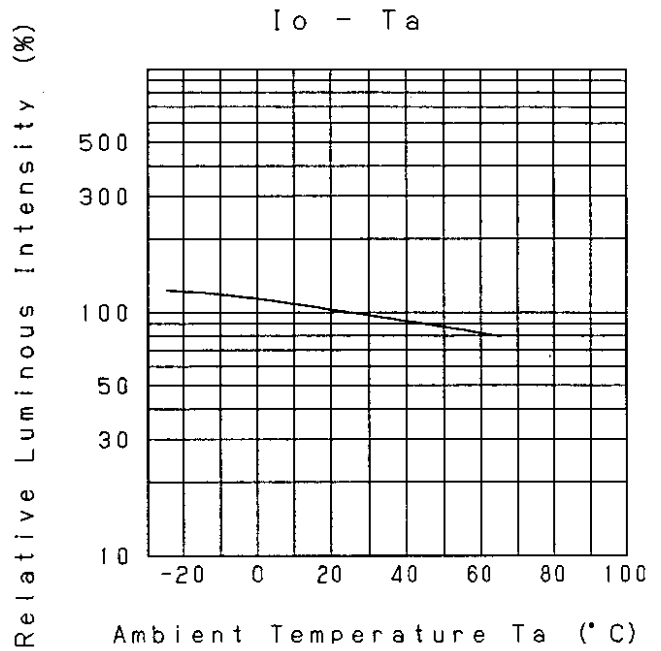
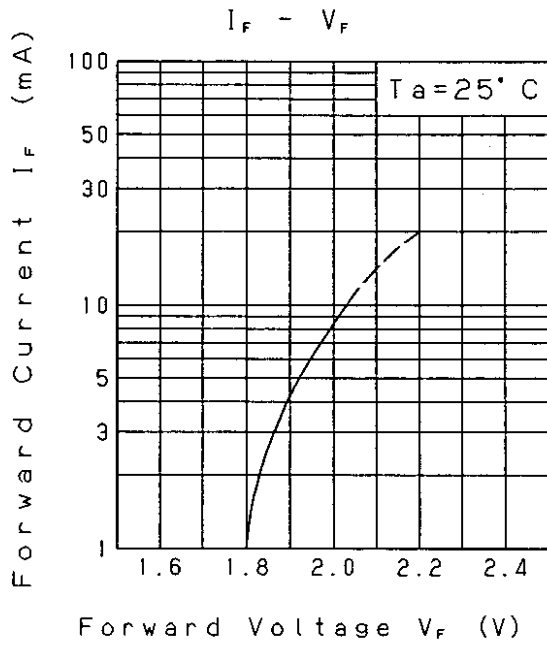

Oct. 27. 2001

Relative Luminous Intensity  
Wavelength Characteristics

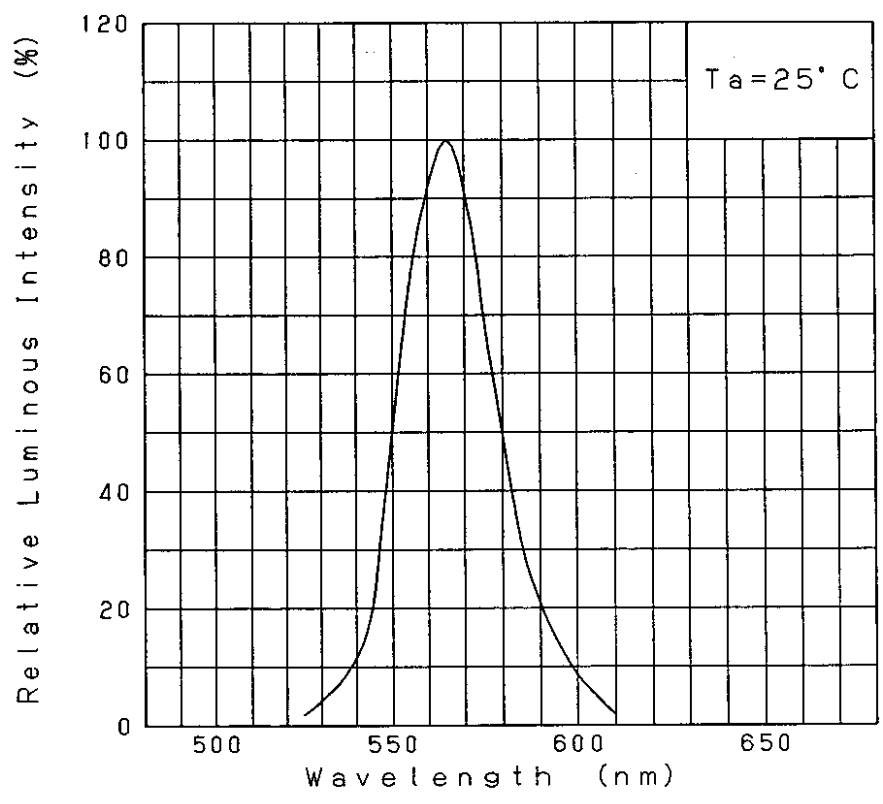

Directive Characteristics

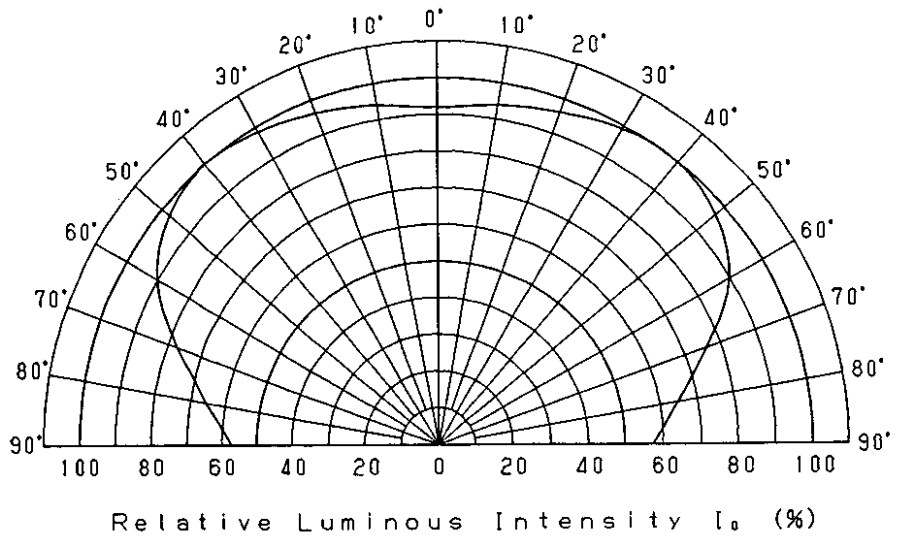

Approved	Checked	Designed	DEVELOPMENT SPECIFICATION (OUTLINE)			
		<i>K. Adams</i>				

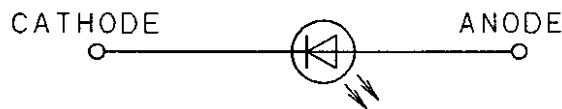
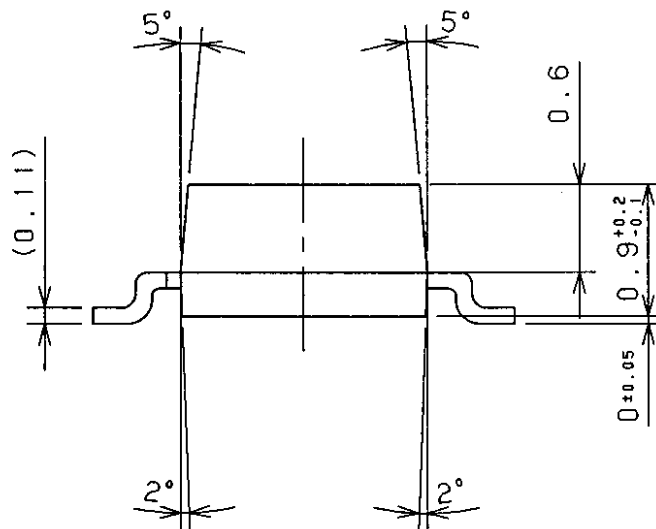
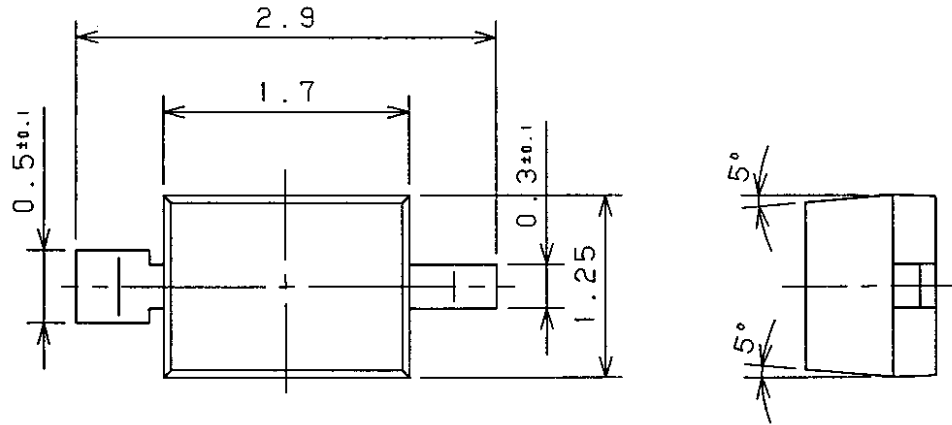

(NOTE)

1. Unit: mm
2. Tolerance unless specified is  $\pm 0.2$ .
3. Measurement of the Package doesn't include gage projection.
4. Corner of the package is R 0.2max.
5. Projection's tolerance of the package is R 0.2max.

Oct. 27. 2001