

DEGREES ARE FOR
REFERENCE ONLY

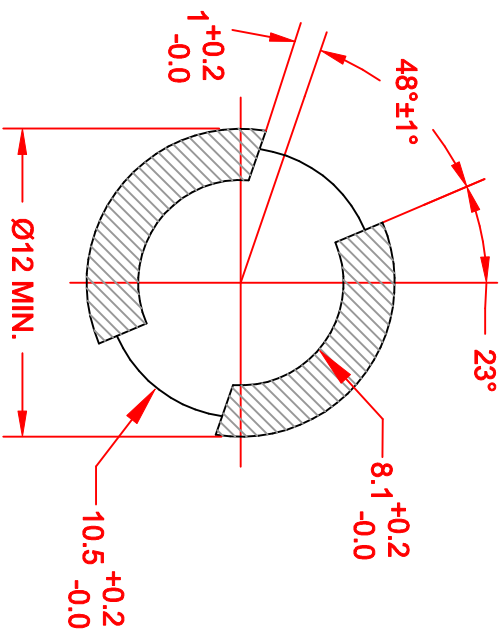
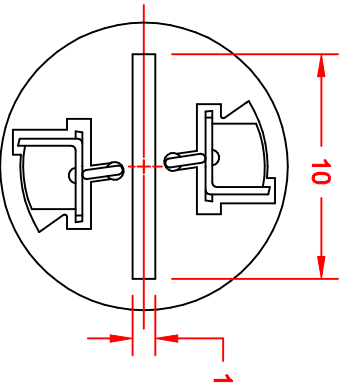
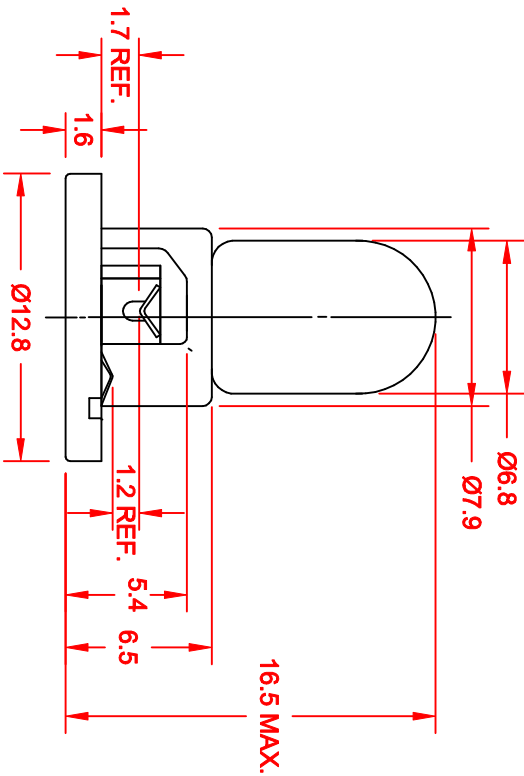
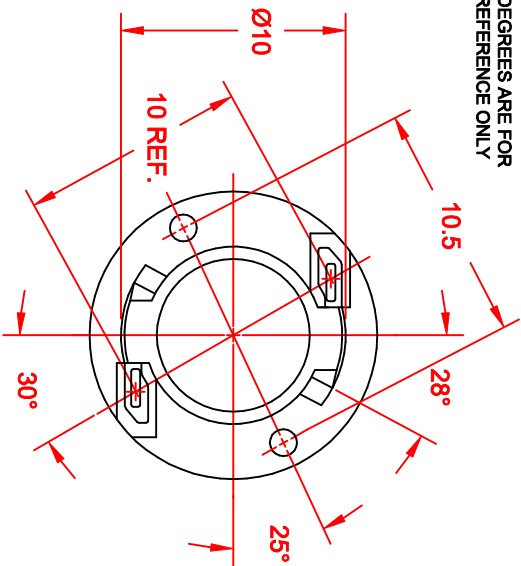

PC BOARD PUNCH PATTERN

JKL LAMP NUMBER	VOLTS RATED	AMPS ±10%	MSCP ±25%	LUMENS ±25%	MINIMUM LIFE HRS.	FILAMENT TYPE
HNW21-HW01	14.0	.240	2.00	25.00	2,500 DC	C-2R

METRIC	DIMENSIONS ARE IN MILLIMETERS	JKL COMPONENTS CORPORATION	
	TOLERANCE UNLESS OTHERWISE SPECIFIED	TITLE	
THIRD ANGLE PROJECTION	1 PL +/- 0.2	T-2 GAS FILLED DUAL CONTACT NEO-WEDGE	
	2 PL +/- 0.20	SIZE	FCGM NO.
	ANGLE +/- 0	A	55335
DRAWN BY L. WENGSTROM	DATE 9/19/03	SCALE	NONE
APPR'D BY J.K.	DATE 9/19/03	RELEASED DATE	9/19/03
- CAD DRAWING -		REVISION DATE	
MANUAL REVISIONS NOT PERMITTED		REV. NO.	1 OF 1
		REV. NO.	

REV.	DESCRIPTION/ECO NO.	DATE
	RELEASED TO CAD	9/19/03