

DESCRIPTION

The LXM1624-12-6x is a Dual 6W Output Direct Drive™ CCFL (Cold Cathode Fluorescent Lamp) Inverter Module specifically designed for driving LCD backlight lamps. It is ideal for driving typical 10.4" to 15" panels.

The modules are available with a dimming input that permits brightness control from either a DC voltage source or a PWM signal or external Potentiometer. The maximum output current is externally programmable over a range of 5 to 8mA in 1mA steps to allow the inverter to properly match to a wide array of LCD panel lamp current specifications.

LXM1624 modules unlike the LXM1623 series does not provide wide range 'burst' mode dimming, rather dimming is provided by amplitude control of the output current waveform, this limits the potential dim range to typically less than 5:1.

For applications not requiring wide range dimming, amplitude control results in lower ripple on the input supply and reduced potential transient noise generation. Many STN type panels are particularly well suited for current amplitude dimming.

The modules convert DC voltage from the system battery or AC adapter directly to high frequency, high-voltage waves required to ignite and operate CCFL lamps.

The modules design is based on Microsemi's new LX1689 backlight controller, which provides a number of cost and performance advantages due to the controller's high level of integration.

Other benefits of this new topology are stable fixed-frequency operation, secondary-side strike-voltage regulation and both open/shorted lamp protection with fault timeout.

IMPORTANT: For the most current data, consult MICROSEMI's website: <http://www.microsemi.com>
 Protected By U.S. Patents: 5,923,129; 5,930,121; 6,198,234; Patents Pending

KEY FEATURES

- Externally Programmable Maximum Output Current
- Easy to Use Brightness Control
- Analog Current Amplitude Dimming Method
- Output Open/Short-Circuit Protection and Automatic Strike-Voltage Regulation and Timeout
- Fixed Frequency Operation
- Rated From -20 to 70°C
- UL60950 E175910

APPLICATIONS

- High Brightness Displays
- Portable Instrumentation
- Desktop Displays
- Industrial Display Controls

BENEFITS

- Compact, Low Profile Design
- Programmable output current allows inverter to mate with a wide variety of LCD panel's specifications
- Output Open Circuit Voltage Regulation Minimizes Corona Discharge For High Reliability

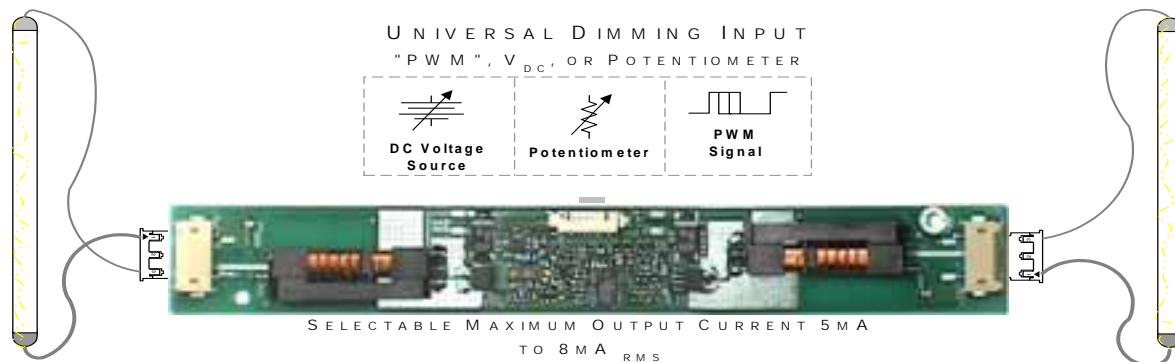
PRODUCT HIGHLIGHT

PACKAGE ORDER INFO

PART NUMBER	OUTPUT CONNECTOR	INVERTER MATES DIRECTLY TO PANEL CONNECTORS
LXM1624-12-61	JST SM02(8.0)B-BHS-1-TB or Yeon Ho 20015WR-05A00	JST BHR-03VS-1
LXM1624-12-62	JST SM02B-BHSS-1-TB or Yeon Ho 35001WR-02A00	JST BHSR-02VS-1
LXM1624-12-63	Honda QZ-19-A3MYL #02	Honda QZ-19-3F01

ABSOLUTE MAXIMUM RATINGS (NOTE 1)

Input Signal Voltage (V_{IN1}).....	-0.3V to 15V
Input Power	15W
Output Voltage, no load	Internally Limited to $1800V_{RMS}$
Output Current	$9.5mA_{RMS}$ (Internally Limited)
Output Power (each output)	6.0W
Input Signal Voltage (SLEEP Input).....	-0.3V to V_{IN1}
Input Signal Voltage (BRITE)	-0.3V to 5.5V
Ambient Operating Temperature, zero airflow.....	-20°C to 70°C
Operating Relative Humidity, non-condensing	≤90%
Storage Temperature Range.....	-40°C to 85°C

Note 1: Exceeding these ratings could cause damage to the device. All voltages are with respect to Ground. Currents are positive into, negative out of specified terminal.

RECOMMENDED OPERATING CONDITIONS (R.C.)

This module has been designed to operate over a wide range of input and output conditions. However, best efficiency and performance will be obtained if the module is operated under the condition listed in the 'R.C.' column. Min. and Max. columns indicate values beyond which the inverter, although operational, will not function optimally.

Parameter	Symbol	Recommended Operating Conditions			Units
		Min	R.C.	Max	
Input Supply Voltage Range (Fully Regulated Lamp Current)	V_{IN1}	10.8	12	13.2	V
Input Supply Voltage Range (Functional)		10.2	12	13.8	
Output Power (each output)	P_O		5.5	6.0	W
Linear BRITE Control Input Voltage Range ¹	V_{BRT_ADJ}	0.65 to 0.9		2.0	V
Lamp Operating Voltage	V_{LAMP}	480	600	720	V_{RMS}
Lamp Current (Full Brightness)	I_{OLAMP}	5		8	mA_{RMS}
Operating Ambient Temperature Range	T_A	-20		70	°C

¹ The minimum V_{BRT_ADJ} voltage depends on the panel characteristics, depending on the panel it can vary from 0.65V to 0.9V

ELECTRICAL CHARACTERISTICS

Unless otherwise specified, the following specifications apply over the recommended operating condition and ambient temperature of 25°C except where otherwise noted.

Parameter	Symbol	Test Conditions	LXM1624-12-6x			Units
			Min	Typ	Max	
OUTPUT PIN CHARACTERISTICS						
Full Bright Lamp Current (each output)	$I_{L(MAX)}$	$V_{BRT_ADJ} \geq 2.0V_{DC}$, $\overline{SLEEP} \geq 2.0V$, $V_{IN1} = 12V_{DC}$ $I_{SET1} = \text{Ground}$, $I_{SET2} = \text{Ground}$	4.4	5	5.6	mA_{RMS}
Full Bright Lamp Current (each output)	$I_{L(MAX)}$	$V_{BRT_ADJ} \geq 2.0V_{DC}$, $\overline{SLEEP} \geq 2.0V$, $V_{IN1} = 12V_{DC}$ $I_{SET1} = \text{Ground}$, $I_{SET2} = \text{Open}$	5.4	6	6.6	mA_{RMS}
Full Bright Lamp Current (each output)	$I_{L(MAX)}$	$V_{BRT_ADJ} \geq 2.0V_{DC}$, $\overline{SLEEP} \geq 2.0V$, $V_{IN1} = 12V_{DC}$ $I_{SET1} = \text{Open}$, $I_{SET2} = \text{Ground}$	6.4	7	7.6	mA_{RMS}
Full Bright Lamp Current (each output)	$I_{L(MAX)}$	$V_{BRT_ADJ} \geq 2.0V_{DC}$, $\overline{SLEEP} \geq 2.0V$, $V_{IN1} = 12V_{DC}$ $I_{SET1} = \text{Open}$, $I_{SET2} = \text{Open}$	7.4	8	8.6	mA_{RMS}
Output Current Lamp to Lamp Deviation	$I_{LL\%DEV}$	$V_{BRT_ADJ} \geq 2.0V_{DC}$, $\overline{SLEEP} \geq 2.0V$, $V_{IN1} = 12V_{DC}$ $I_{SET1} = \text{Open}$, $I_{SET2} = \text{Open}$		3	10	%
Min. Average Lamp Current (each output)	$I_{L(MIN)}$	$V_{BRT_ADJ} \leq 0.5V_{DC}$, $\overline{SLEEP} \geq 2.0V$, $V_{IN1} = 12V_{DC}$ $I_{SET1} = I_{SET2} = \text{Ground}$		2 ²		mA_{RMS}
Lamp Start Voltage	V_{LS}	-20°C < T_A < 70°C, $V_{IN1} > 10.8V_{DC}$	1400	1650		V_{RMS}
Operating Frequency	f_O	$V_{BRT_ADJ} = 2.5V_{DC}$, $\overline{SLEEP} \geq 2.0V$, $V_{IN1} = 12V$	66	70	73	kHz

² The inverter is capable of a lower output current than may be recommended by the panel manufacturer. It is the user's responsibility to set the minimum brightness (BRITE) input at or above the panel specification for minimum current.

ELECTRICAL CHARACTERISTICS (CONTINUED)

Unless otherwise specified, the following specifications apply over the recommended operating condition and ambient temperature of 25°C except where otherwise noted.

Parameter	Symbol	Test Conditions	LXM1624-12-6x			Units
			Min	Typ	Max	
BRITE INPUT						
Input Current	I _{BRT}	V _{BRT_ADJ} = 0V _{DC}		-300		μA _{DC}
		V _{BRT_ADJ} = 3V _{DC}		50		μA _{DC}
Minimum Input for Max. Lamp Current	V _{BRT_ADJ}	I _{O(LAMP)} = Maximum Lamp Current		2.0	2.05	V _{DC}
Minimum Input for Min. Lamp Current	V _{BRT_ADJ}	I _{O(LAMP)} = Minimum Lamp Current	0.65*			V _{DC}
SLEEP INPUT						
RUN Mode	V _{SLEEP}		2.0		V _{IN1}	V _{DC}
SLEEP Mode	V _{SLEEP}		-0.3		0.8	V _{DC}
SET_{1,2} INPUT						
SET _{1,2} Low Threshold	V _L				0.4	V
Input Current	I _{SET}	V _{SET} ≤ 0.4V		-300		μA
POWER CHARACTERISTICS						
Sleep Current	I _{IN(MIN)}	V _{IN1} = 12V _{DC} , SLEEP ≤ 0.8V	0.0	10	30	μA _{DC}
Run Current	I _{IN(RUN)}	V _{IN1} = 12V _{DC} , SLEEP ≥ 2.0V, I _{SET1} = Open I _{SET2} = Ground, V _{LAMP} = 600V _{RMS}		875		mA _{DC}
Efficiency	η	V _{IN1} = 12V _{DC} , SLEEP ≥ 2.0V, I _{SET1} = Open I _{SET2} = Ground, V _{LAMP} = 600V _{RMS}		85		%

* The Inverter is capable of a lower output current than may be recommended by the panel manufacturer. It is the user's responsibility to set the minimum brightness (BRITE) input at or above the panel specification for minimum current. This is likely greater than the 0.65V minimum input.

FUNCTIONAL PIN DESCRIPTION

CONN	PIN	DESCRIPTION
CN1 (Molex 53261-0890) Mates with 51021-0800 housing, 50079-8100 pins. Mates with LX9501 input cable assembly		
CN1-1	V _{IN1}	Main Input Power Supply (10.8V ≤ V _{IN1} ≤ 13.2V)
CN1-2		
CN1-3	GND	Power Supply Return
CN1-4		
CN1-5	SLEEP	ON/OFF Control. (0V < SLEEP < 0.8 = OFF, SLEEP ≥ 2.0V = ON)
CN1-6	BRITE	Brightness Control (0.65V to 2.0V _{DC}). 2.0V _{DC} gives maximum lamp current.
CN1-7	SET ₁	SET ₁ MSB Connecting this pin to ground decreases the output current (see Table 1)
CN1-8	SET ₂	SET ₂ LSB Connecting this pin to ground decreases the output current (see Table 1)
CN2, CN3 for LXM1624-12-61 and -62 (JST SM02(8.0)B-BHS-1-TB Yeon Ho 20015WR-05A00 or SM02B-BHSS-1-TB Yeon Ho 35001WR-0200)		
CN2-1 CN3-1	V _{HI}	High voltage connection to high Side of lamp. Connect to lamp terminal with shortest lead length. DO NOT connect to Ground.
CN2-2 CN3-2	V _{LO}	Connection to low side of lamp. Connect to lamp terminal with longer lead length. DO NOT connect to Ground
CN2, CN3 for LXM1624-12-63 (Honda QZ-19-A3MYL #02)		
CN2-3 CN3-3	V _{HI}	High voltage connection to high side of lamp. Connect to lamp terminal with shortest lead length. DO NOT connect to Ground.
CN2-1 CN3-1	V _{LO}	Connection to low side of lamp. Connect to lamp terminal with longer lead length. DO NOT connect to Ground

TABLE 1

OUTPUT CURRENT SETTINGS

SET ₁ (Pin 7)	SET ₂ (Pin 8)	Nominal Output Current
Open*	Open*	8.0mA
Open*	Ground	7.0mA
Ground	Open*	6.0mA
Ground	Ground	5.0mA

* If driven by a logic signal it should be open collector or open drain only, not a voltage source.

PHYSICAL DIMENSIONS

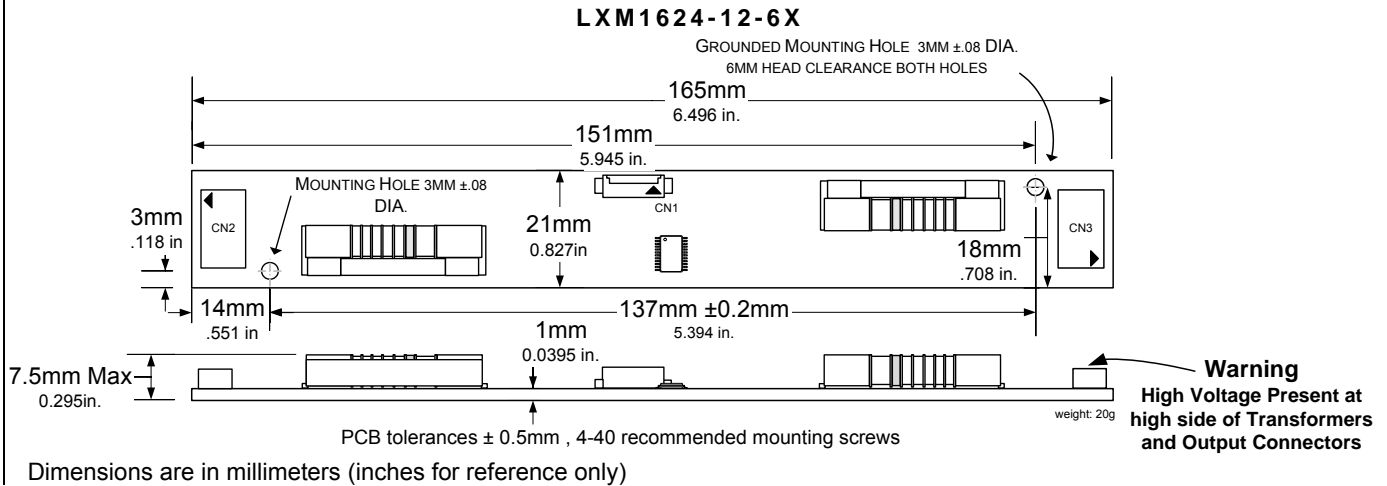

SIMPLIFIED BLOCK DIAGRAM

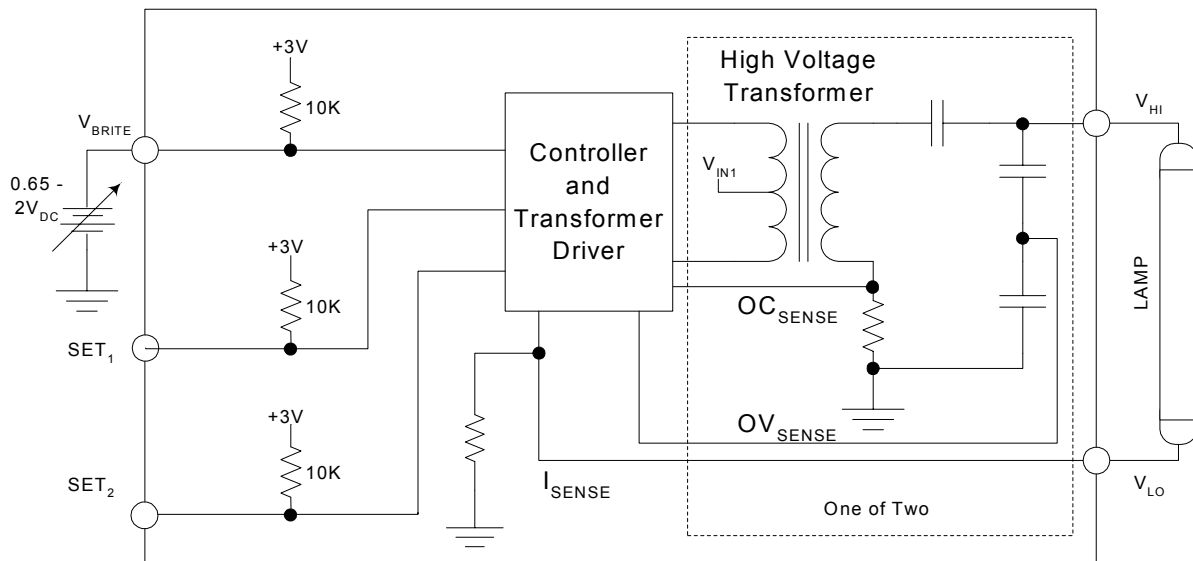

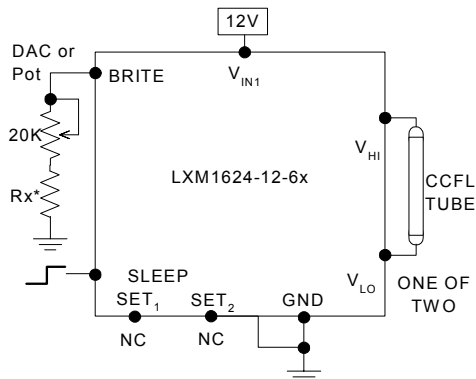
TYPICAL APPLICATION

*Set Rx from 1.8K to 3.9K depending on panel minimum lamp current requirements

Figure 1 – Brightness Control
(Output current set to maximum)

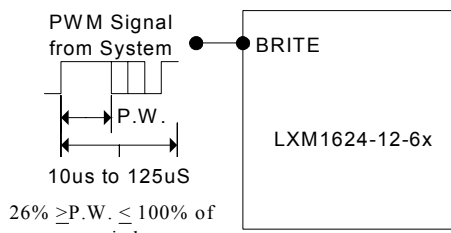
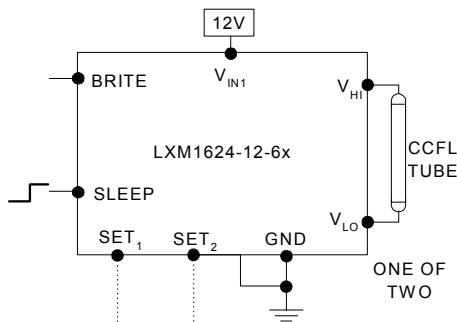

Figure 1A – PWM Brightness Control



L	L	5.0mA _{RMS}
L	H	6.0mA _{RMS}
H	L	7.0mA _{RMS}
H	H	8.0mA _{RMS}

L=GND; H=Open

Figure 2 – Max Output Current
(SET₁ and SET₂ Inputs)

- The brightness control may be a voltage output DAC or other voltage source, a digital pot or 20K manual pot. The inverter contains an internal 10K pull-up to 3V to bias the pot, add a 1.8K to 3.9K resistor to set the lower threshold voltage. A 3.3V Logic Level PWM signal from a micro-controller may also be used as shown in Figure 1A.
- If you need to turn the inverter ON/OFF remotely, connect to TTL logic signal to the SLEEP input.
- Connect V_{HI} to high voltage wire from the lamp. Connect V_{LO} to the low voltage wire (wire with thinner insulation). Never connect V_{LO} to circuit ground as this will defeat lamp current regulation. If both lamp wires have heavy high voltage insulation, connect the longest wire to V_{LO}. This wire is typically white.≥
- Use the SET₁ and SET₂ (see Figure 2) inputs to select the desired maximum output current. Using these two pins in combination allows the inverter to match a wide variety of panels from different manufactures. Generally the best lamp lifetime correlates with driving the CCFL at the manufactures nominal current setting. However the SET₁ and SET₂ inputs allow the user the flexibility to adjust the current to the maximum allowable output current to increase panel brightness at the expense of some reduced lamp life.
- Although the SET pins are designed such that just leaving them open or grounding them is all that is needed to set the output current, they can also be actively set. Using an open collector or open drain logic signal will allow you to reduce the lamp current for situations where greater dim range is required, as an example in nighttime situations. In conjunction with a light sensor or other timer the panel could be set to higher brightness (maximum output current) for daytime illumination and lower brightness (minimum or typical output current) at nighttime. Since the dim ratio is a factor of both the burst duty cycle and the peak output current, using this technique the effective dim ratio can be increased greater than the burst duty cycle alone. Conversely the SET inputs could be used to overdrive the lamp temporarily to facilitate faster lamp warm up at initial lamp turn on. Of course any possible degradation on lamp life from such practices is the users responsibility since not all lamps are designed to be overdriven.
- The inverter has a built in fault timeout function. If the output is open (lamp disconnected or broken) or shorted the inverter will attempt to strike the lamp for several seconds. After about 2 seconds without success the inverter will shutdown. In order to restart the inverter it is necessary to toggle the sleep input or cycle the V_{IN1} input supply

NOTES

PRODUCTION DATA – Information contained in this document is proprietary to Microsemi and is current as of publication date. This document may not be modified in any way without the express written consent of Microsemi. Product processing does not necessarily include testing of all parameters. Microsemi reserves the right to change the configuration and performance of the product and to discontinue product at any time.