

Model

LS380-RH

RoHS COMPLIANT

12 Volt Input

Single Tube CCFT Inverter

Brightness Control

Physical Specifications

Dimensions:	20mm x 85mm x 7.3mm (0.787" x 3.35" x 0.287")
Weight:	10g (0.352 oz.)
Operating Temp:	0 to 55°C, convection cooling
Relative Humidity:	20% to 90%, non-condensing
Storage:	-20 to 85°C/5-95% RH, non-condensing
Impact Resistance:	50G half wave per 2 msec
Vibration Resistance:	10-55-10 Hz/min @ 1.5mm



Input Specifications*

Item	Condition	Standard		
		MIN	TYP	MAX
Input Voltage Rated Tolerance	—	12 Vdc		
	Continuous Operation Starting Condition (Discharge Starting Voltage)	10 Vdc - 16 Vdc		
Max. Input Current	$V_{IN} = 10$ Vdc Luminance @ Max.	0.5 A		
Input Current	Control terminal $H = (V_{IN})$ $V_{IN} = 16$ Vdc	3.0 μ A (Lamp Off)		
Max. Rush Current	$V_{IN} = 16$ Vdc Luminance @ Max.	3.0 A zero-p/0.3 mS		
Max. Input Power	$V_{IN} = 16$ Vdc Luminance @ Max.	3.5 W		
Control Terminal Input Current	Control Terminal $L = 0.0 - 0.4$ Vdc $V_{IN} = 16$ Vdc	$I_{Low} = -0.4$ mA (Lamp Lighting)		
	Control Terminal $H = Open$	— (Lamp Off)		

*Above specifications occur @ 25 \pm 5°C.

Output Specifications*

Item	Condition	Standard		
		MIN	TYP	MAX
Output Voltage (Vrms)	$V_{IN} = 12$ Vdc	—	1500	—
Tube Current (mArms)	Luminance @ Max.	5.5	6.5	7.5
	Luminance @ Min.	—	3.0	—
Max. Power Output (W)	$V_{IN} = 12.0$ Vdc/Luminance @ Max.	—	—	3.5
Ignition Frequency (kHz)	Luminance @ Max.	30	40	50
DC/DC Converter Frequency (kHz)	Luminance @ Max.	—	80	—

*Above specifications occur @ 25 \pm 5°C & $V_{IN} = 10 - 16$ Vdc.

Model

LS380-RH

Insulating Withstand Voltage

Item	Rating Description	
Insulating Withstand Voltage	Primary - Secondary	1.5 kVA Impulse
Insulating Resistance	Primary - Secondary Winding - Core	500 Vdc More than 100 MΩ

Luminance Variance

Item	Condition	Standard
Luminance @ Max.	Btwn. pin 4 & pin 5	0.0 Ω
Luminance @ Min.	Btwn. pin 4 & pin 5	10 kΩ

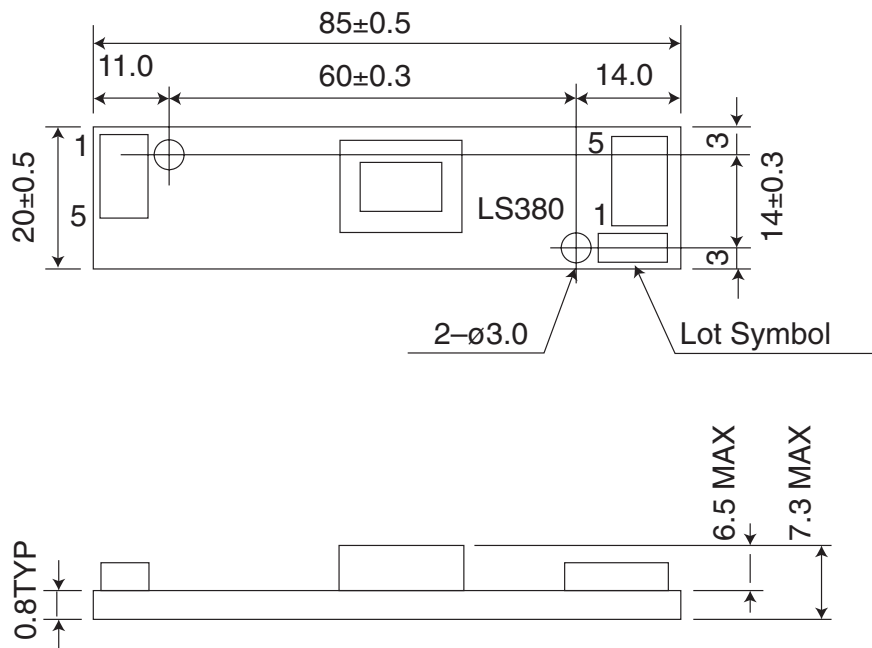

© Copyright 2007 TAIYO YUDEN (U.S.A.), INC. Specifications subject to change without notice.

TAIYO YUDEN

TAIYO YUDEN (U.S.A.), INC.
440 Stevens Avenue, Suite 300 Solana Beach, CA 92075
(858) 350-6800 / Fax: (858) 350-6854
(800) 263-4532 www.t-yuden.com inverters@t-yuden.com



FM 32227

Model

LS380-RH

Tech Notes

Connection Diagram

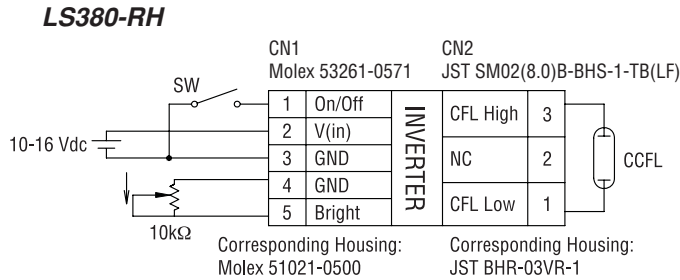

On/Off Control

The on/off control is achieved by using the on/off pin on the input side of LS380. The circuit for the remote on/off circuitry consists of an active low TTL switch. When the circuit is open, the IC Vcc is cut off. When the circuit is closed, IC Vcc is activated. A mechanical switch or a TTL/CMOS gate needs to be placed between the remote on/off pin and ground creating a condition where the circuit is closed to activate the inverter. Either one of the following will be required for the inverter to operate:

One recommended use of logic switch for remote on/off is shown in the diagram below. Electrical specification for on/off terminal is Low 0 to 0.4V, -0.4 mA or higher when switch is closed.

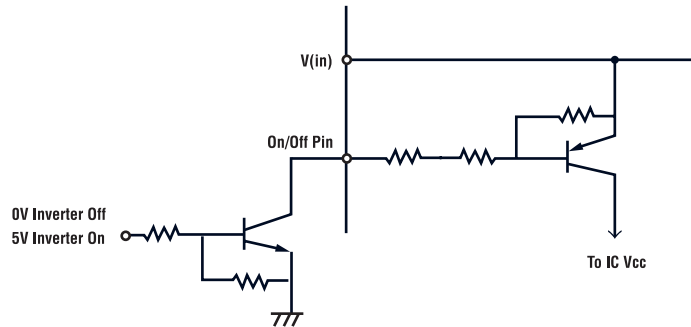
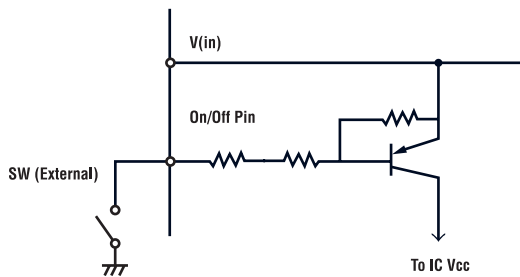

1. Tie on/off pin to ground.
2. Add mechanical switch between on/off pin and ground, close switch.
3. Add TTL/CMOS switch between on/off and ground. Circuit must be closed for unit to operate (as shown above right).

© Copyright 2007 TAIYO YUDEN (U.S.A.), INC. Specifications subject to change without notice.

TAIYO YUDEN

TAIYO YUDEN (U.S.A.), INC.
 440 Stevens Avenue, Suite 300 Solana Beach, CA 92075
 (858) 350-6800 / Fax: (858) 350-6854
 (800) 263-4532 www.t-yuden.com inverters@t-yuden.com



FM 32227

Model

LS380-RH

Tech Notes

Output Current Optimization Method

Maximum output current can be adjusted by applying bias voltage or using a solid resistor as shown below.

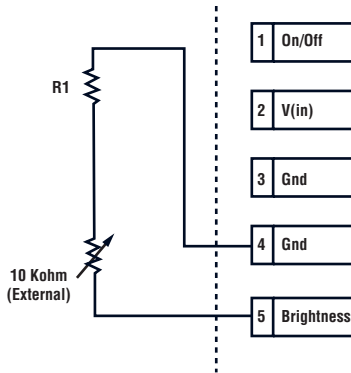

dimming by using a variable resistor

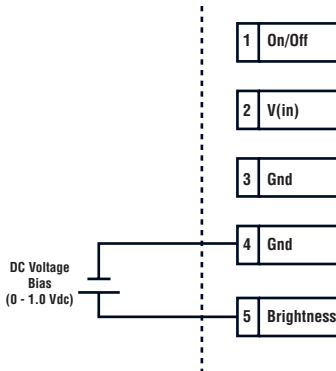

dimming by applying DC bias voltage

R1	Minimum Typ. Output Current	Maximum Output Current
N/A	3.0 mA	7.5 mA
270 Ω	3.0 mA	6.5 mA
820 Ω	3.0 mA	6.0 mA
1.6 KΩ	3.0 mA	5.5 mA
2.7 KΩ	3.0 mA	5.0 mA
3.8 KΩ	3.0 mA	4.5 mA
5.6 Ω	3.0 mA	4.0 mA

Notes:

Allowable maximum input current for backlight CCFT is stipulated on the LCD specification.

Please select resistor value per requirements on the panel.

For more information, please contact Taiyo Yuden (USA), Inc.

DC Bias	Output Current
0 V	6.42 mA
0.1 V	6.00 mA
0.2 V	5.58 mA
0.3 V	5.20 mA
0.4 V	4.70 mA
0.5 V	4.43 mA
0.6 V	4.05 mA
0.7 V	3.64 mA
0.8 V	3.23 mA
0.9 V	2.86 mA
1.0 V	2.48 mA

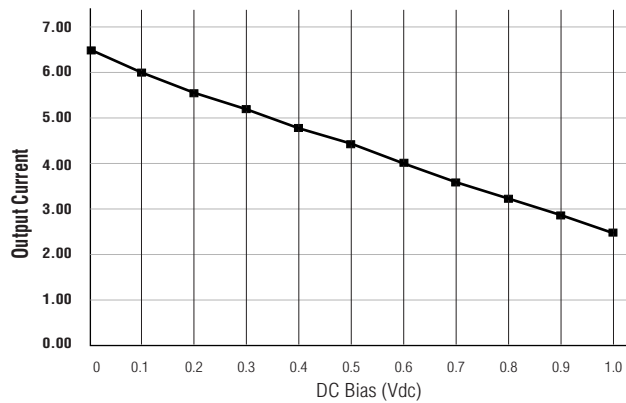

Mean Time Between Failures (MTBF)

By using the MIL-HDBK 217E Condition Ground Benign method, the MTBF for the LS380 is calculated at 1,121,453 hours.

© Copyright 2007 TAIYO YUDEN (U.S.A.), INC. Specifications subject to change without notice.

TAIYO YUDEN

TAIYO YUDEN (U.S.A.), INC.
 440 Stevens Avenue, Suite 300 Solana Beach, CA 92075
 (858) 350-6800 / Fax: (858) 350-6854
 (800) 263-4532 www.t-yuden.com inverters@t-yuden.com



FM 32227