

DESCRIPTION

The LXMG1626-12-64 is a Dual 6W Output Direct DriveTM CCFL (Cold Cathode Fluorescent Lamp) Inverter Module specifically designed to be compatible with the Sharp LQ150X1LGN2(A),(H), 15" or similar dual lamp displays that have both individual lamp output connectors on the one side of the panel.

LXMG1626 modules provide the designer with a vastly superior display brightness range. This brightness range is achievable with virtually any LCD display.

The modules are available with a dimming input that permits brightness control from either, a DC voltage source, a PWM signal or external Potentiometer.

The maximum output current is externally programmable (through the input connector) over a range of 3.5 to 5mA in 0.5mA steps. This allows the inverter to match the panel's lamp current specifications, or it can be used to purposely drive the lamps at a lower or higher current to decrease or increase nominal brightness.

RangeMAX Digital Dimming Technique provides flicker-free brightness control in any wide range typically (100:1+) dimming application.

The resultant "burst drive" that energizes the lamp is designed specifically to ensure that no premature lamp degradation occurs, while allowing significant power savings at lower dim levels.

The modules convert DC voltage from the system battery or AC adapter directly to high frequency, high-voltage waves required to ignite and operate CCFL lamps.

The modules design utilizes Microsemi's LX1691 Enhanced Multi-mode CCFL backlight controller, which provides a number of cost and performance advantages due to the controller's high level of integration.

Other benefits of this new topology are stable fixed-frequency operation, secondary-side strike-voltage regulation and both open/shorted lamp protection with fault timeout.

KEY FEATURES

- Externally Programmable Maximum Output Current
- Easy to Use Brightness Control
- RangeMAX Wide Range Dimming
- Output Open & Short-Circuit Protection and Automatic Strike-Voltage Regulation and Timeout
- Fixed Frequency Operation
- Rated From -20 to 70°C
- UL60950 E175910
- RoHS Compliant

APPLICATIONS

- LCD's requiring both output connectors on one side of panel
- Sharp LQ150X1LGN2(A)(H)
- Desktop Displays
- Industrial Display Controls

BENEFITS

- Smooth, Flicker Free 1%-100% Full-Range Brightness Control
- Programmable output current allows inverter to mate with a wide variety of LCD panel's specifications
- Output Open Circuit Voltage Regulation Minimizes Corona Discharge For High Reliability

IMPORTANT: For the most current data, consult MICROSEMI's website: <http://www.microsemi.com>
Protected By U.S. Patents: 5,923,129; 5,930,121; 6,198,234; Patents Pending

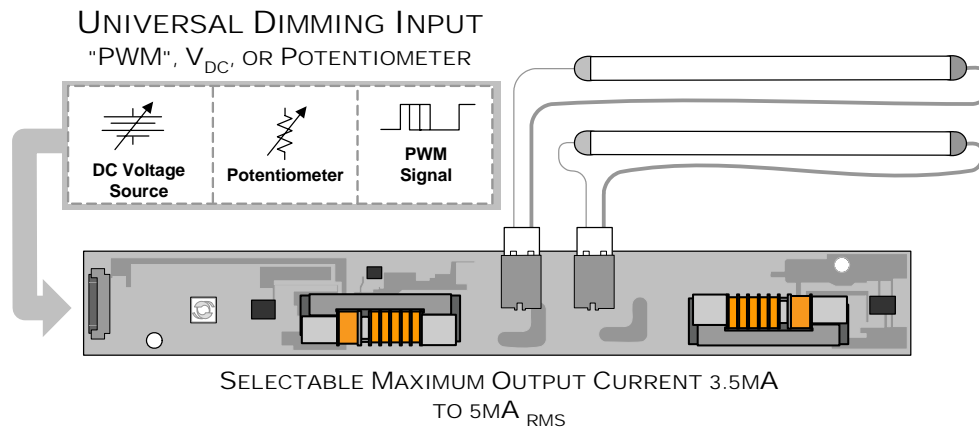
PRODUCT HIGHLIGHT

PACKAGE ORDER INFO

PART NUMBER	OUTPUT CONNECTOR	INVERTER MATES DIRECTLY TO PANEL CONNECTORS
LXMG1626-12-64	JST SM02B-BHSS-1-TB(LF)(SN) or Yeon Ho 35001WR-02A00	JST BHSR-02VS-1

ABSOLUTE MAXIMUM RATINGS (NOTE 1)

Input Signal Voltage (V_{IN1}).....	-0.3V to 16V
Input Power	14W
Output Voltage, no load	Internally Limited to 1800V _{RMS}
Output Current	7.5mA _{RMS} (Internally Limited)
Output Power (each output)	6.0W
Input Signal Voltage (SLEEP Input).....	-0.3V to V_{IN1}
Input Signal Voltage (BRITE)	-0.3V to 5.5V
Ambient Operating Temperature, zero airflow.....	-20°C to 70°C
Operating Relative Humidity, non-condensing	≤90%
Storage Temperature Range.....	-40°C to 85°C

Note 1: Exceeding these ratings could cause damage to the device. All voltages are with respect to Ground. Currents are positive into, negative out of specified terminal.

RECOMMENDED OPERATING CONDITIONS (R.C.)

This module has been designed to operate over a wide range of input and output conditions. However, best efficiency and performance will be obtained if the module is operated under the condition listed in the 'R.C.' column. Min. and Max. columns indicate values beyond which the inverter, although operational, will not function optimally.

Parameter	Symbol	Recommended Operating Conditions			Units
		Min	R.C.	Max	
Input Supply Voltage Range (Fully Regulated Lamp Current)	V_{IN1}	10.8	12	13.2	V
Input Supply Voltage Range (Functional)		10.2	12	14.4	
Output Power (each output)	P_O		4.4	5.5	W
Linear BRITE Control Input Voltage Range	V_{BRT_ADJ}	0.1		2.0	V
Lamp Operating Voltage	V_{LAMP}		1100	1250*	V _{RMS}
Lamp Current (Full Brightness)	I_{OLAMP}	3.5		5.0	mA _{RMS}
Operating Ambient Temperature Range	T_A	-20		70	°C

* Total output power must not exceed 6W. Higher voltage lamps may require maximum output current to be set lower than 5mA_{RMS}

ELECTRICAL CHARACTERISTICS

Unless otherwise specified, the following specifications apply over the recommended operating condition and ambient temperature of 25°C except where otherwise noted.

Parameter	Symbol	Test Conditions	LXMG1626-12-64			Units
			Min	Typ	Max	
OUTPUT PIN CHARACTERISTICS						
Full Bright Lamp Current (each output)	$I_{L(MAX)}$	$V_{BRT_ADJ} \geq 2.0V_{DC}$, SLEEP $\geq 2.0V$, $V_{IN1} = 12V_{DC}$ $I_{SET1} = \text{Ground}$, $I_{SET2} = \text{Ground}$	3.0	3.5	4.0	mA _{RMS}
Full Bright Lamp Current (each output)	$I_{L(MAX)}$	$V_{BRT_ADJ} \geq 2.0V_{DC}$, SLEEP $\geq 2.0V$, $V_{IN1} = 12V_{DC}$ $I_{SET1} = \text{Ground}$, $I_{SET2} = \text{Open}$	3.5	4.0	4.5	mA _{RMS}
Full Bright Lamp Current (each output)	$I_{L(MAX)}$	$V_{BRT_ADJ} \geq 2.0V_{DC}$, SLEEP $\geq 2.0V$, $V_{IN1} = 12V_{DC}$ $I_{SET1} = \text{Open}$, $I_{SET2} = \text{Ground}$	4.0	4.5	5.0	mA _{RMS}
Full Bright Lamp Current (each output)	$I_{L(MAX)}$	$V_{BRT_ADJ} \geq 2.0V_{DC}$, SLEEP $\geq 2.0V$, $V_{IN1} = 12V_{DC}$ $I_{SET1} = \text{Open}$, $I_{SET2} = \text{Open}$	4.5	5.0	5.5	mA _{RMS}
Output Current Lamp to Lamp Deviation	$I_{LL\%DEV}$	$V_{BRT_ADJ} \geq 2.0V_{DC}$, SLEEP $\geq 2.0V$, $V_{IN1} = 12V_{DC}$ $I_{SET1} = \text{Open}$, $I_{SET2} = \text{Open}$		3		%
Min. Average Lamp Current (each output)	$I_{L(MIN)}$	$V_{BRT_ADJ} = 0V_{DC}$, SLEEP $\geq 2.0V$, $V_{IN1} = 12V_{DC}$ $I_{SET1} = I_{SET2} = \text{Ground}$		0.08		mA _{RMS}
Lamp Start Voltage	V_{LS}	-20°C < T_A < 70°C, $V_{IN1} > 10.8V_{DC}$	1450	1650		V _{RMS}
Operating Frequency	f_O	$V_{BRT_ADJ} = 2.5V_{DC}$, SLEEP $\geq 2.0V$, $V_{IN1} = 12V$	62	65	68	kHz
Burst Frequency	f_{BURST}	Output Burst Frequency	121	127	133	Hz

ELECTRICAL CHARACTERISTICS (CONTINUED)

Unless otherwise specified, the following specifications apply over the recommended operating condition and ambient temperature of 25°C except where otherwise noted.

Parameter	Symbol	Test Conditions	LXMG1626-12-64			Units
			Min	Typ	Max	
BRITE INPUT						
Input Current	I _{BRT}	V _{BRT_ADJ} = 0V _{DC}		-15		μA _{DC}
		V _{BRT_ADJ} = 3V _{DC}		1		μA _{DC}
Minimum Input for Max. Lamp Current	V _{BRT_ADJ}	I _{O(LAMP)} = Maximum Lamp Current		2.0	2.05	V _{DC}
Maximum Input for Min. Lamp Current	V _{BRT_ADJ}	I _{O(LAMP)} = Minimum Lamp Current	0			V _{DC}
SLEEP INPUT						
RUN Mode	V _{SLEEP}		2.1		V _{IN1}	V _{DC}
SLEEP Mode	V _{SLEEP}		-0.3		0.8	V _{DC}
SET_{1,2} INPUT						
SET _{1,2} Low Threshold	V _L				0.4	V
Input Current	I _{SET}	V _{SET} ≤ 0.4V		-300		μA
POWER CHARACTERISTICS						
Sleep Current	I _{IN(MIN)}	V _{IN1} = 12V _{DC} , $\overline{\text{SLEEP}} \leq 0.8\text{V}$	0.0	10	50	μA _{DC}
Run Current	I _{IN(RUN)}	V _{IN1} = 12V _{DC} , $\overline{\text{SLEEP}} \geq 2.0\text{V}$, I _{SET1} = Ground I _{SET2} = Open, V _{LAMP} = 1050V _{RMS}		960		mA _{DC}
Efficiency	η	V _{IN1} = 12V _{DC} , $\overline{\text{SLEEP}} \geq 2.0\text{V}$, I _{SET1} = Ground I _{SET2} = Open, V _{LAMP} = 1050V _{RMS}		78		%

FUNCTIONAL PIN DESCRIPTION

CONN	PIN	DESCRIPTION
CN1 (Molex 53261-0871) Mates with 51021-0800 housing, 50079-8100 pins. Mates with LX9501G input cable assembly		
CN1-1	V _{IN1}	Main Input Power Supply (10.8V ≤ V _{IN1} ≤ 13.2V)
CN1-2		
CN1-3	GND	Power Supply Return
CN1-4		
CN1-5	$\overline{\text{SLEEP}}$	ON/OFF Control. (0V < $\overline{\text{SLEEP}}$ < 0.8 = OFF, $\overline{\text{SLEEP}}$ ≥ 2.1V = ON)
CN1-6	BRITE	Brightness Control (0V to 2.0V _{DC}). 2.0V _{DC} gives maximum lamp current.
CN1-7	SET ₁	SET ₁ MSB Connecting this pin to ground decreases the output current (see Table 1)
CN1-8	SET ₂	SET ₂ LSB Connecting this pin to ground decreases the output current (see Table 1)
CN2, CN3 for LXMG1626-12-64 (JST SM02B-BHSS-1-TB(LF)(SN) or Yeon Ho 35001WR-02A00)		
CN2-1 CN3-1	V _{HI}	High voltage connection to high Side of lamp. Connect to lamp terminal with shortest lead length. DO NOT connect to Ground.
CN2-2 CN3-2	V _{LO}	Connection to low side of lamp. Connect to lamp terminal with longer lead length. DO NOT connect to Ground

TABLE 1
OUTPUT CURRENT SETTINGS

SET ₁ (Pin 7)	SET ₂ (Pin 8)	Nominal Output Current
Open*	Open*	5.0mA
Open*	Ground	4.5mA
Ground	Open*	4.0mA
Ground	Ground	3.5mA

* If driven by a logic signal it should be open collector or open drain only, not a voltage source.

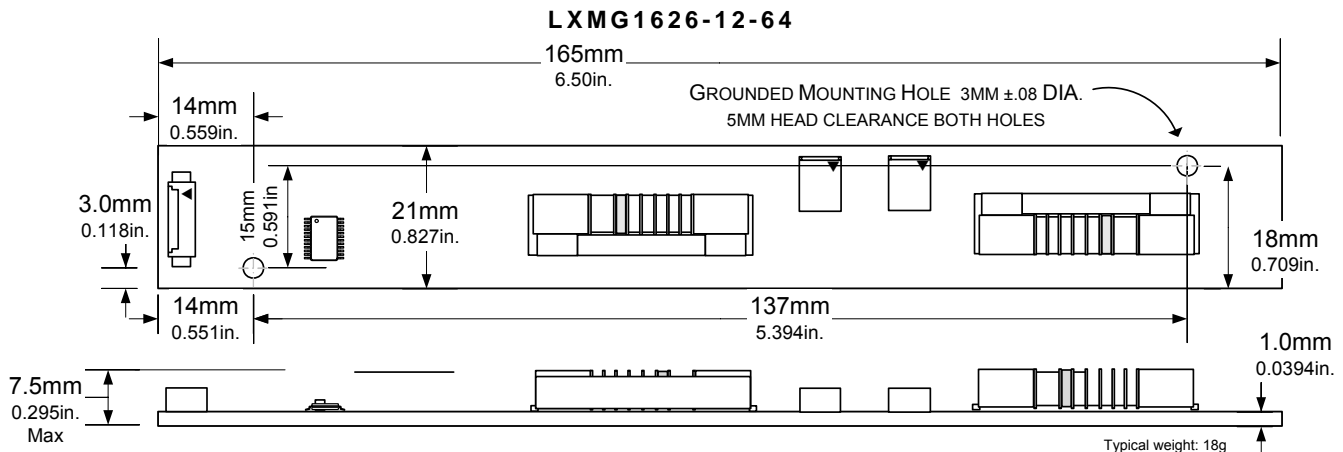
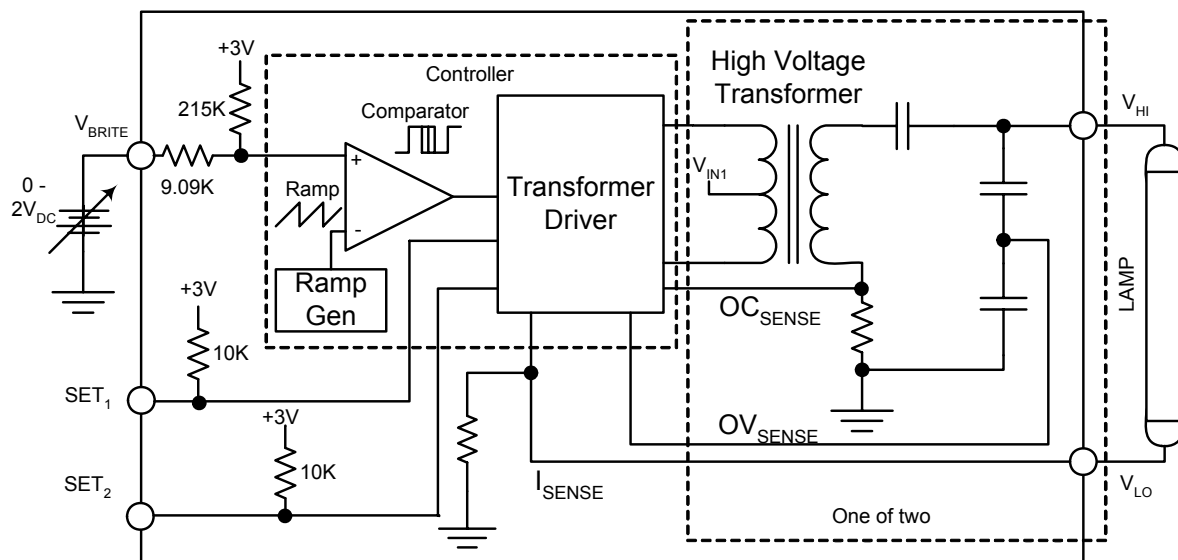
PHYSICAL DIMENSIONS

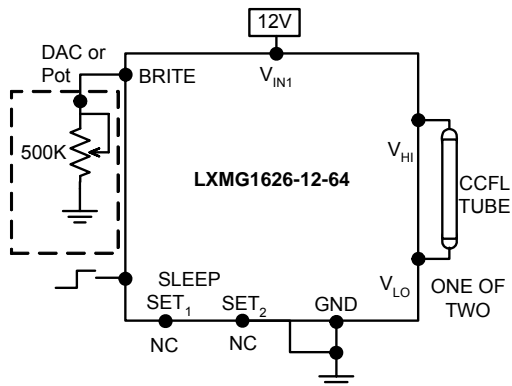
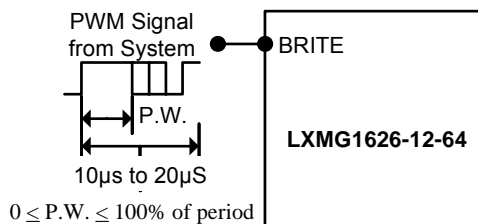
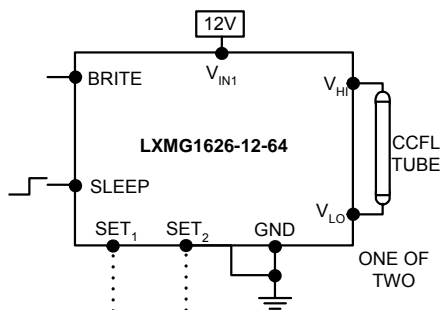
SIMPLIFIED BLOCK DIAGRAM

TYPICAL APPLICATION

Figure 1 – Brightness Control
 (Output current set to maximum)

Figure 1A – PWM Brightness Control

L	L	3.5mA _{RMS}
L	H	4.0mA _{RMS}
H	L	4.5mA _{RMS}
H	H	5.0mA _{RMS}

L=GND; H=Open

Figure 2 – Max Output Current
 (SET₁ and SET₂ Inputs)

- The brightness control may be a voltage output DAC or other voltage source, a digital pot or 500K manual pot. The inverter contains an internal 215K pull-up to 3V to bias the pot. A 3.3V Logic Level PWM signal from a micro-controller may also be used as shown in Figure 1A.
- If you need to turn the inverter ON/OFF remotely, connect to TTL logic signal to the SLEEP input.
- Connect V_{HI} to high voltage wire from the lamp. Connect V_{LO} to the low voltage wire (wire with thinner insulation). Never connect V_{LO} to circuit ground as this will defeat lamp current regulation. If both lamp wires have heavy high voltage insulation, connect the longest wire to V_{LO}. This wire is typically white.
- Use the SET₁ and SET₂ (see Figure 2) inputs to select the desired maximum output current. Using these two pins in combination allows the inverter to match a wide variety of panels from different manufactures. Generally the best lamp lifetime correlates with driving the CCFL at the manufactures nominal current setting. However the SET₁ and SET₂ inputs allow the user the flexibility to adjust the current to the maximum allowable output current to increase panel brightness at the expense of some reduced lamp life.
- Although the SET pins are designed such that just leaving them open or grounding them is all that is needed to set the output current, they can also be actively set. Using an open collector or open drain logic signal will allow you to reduce the lamp current for situations where greater dim range is required, as an example in nighttime situations. In conjunction with a light sensor or other timer the panel could be set to higher brightness (maximum output current) for daytime illumination and lower brightness (minimum or typical output current) at nighttime. Since the dim ratio is a factor of both the burst duty cycle and the peak output current, using this technique the effective dim ratio can be increased greater than the burst duty cycle alone. Conversely, the SET inputs could be used to overdrive the lamp temporarily to facilitate faster lamp warm up at initial lamp turn on. Of course, any possible degradation on lamp life from such practices is the user's responsibility since not all lamps are designed to be overdriven.
- The inverter has a built in fault timeout function. If the output is open (lamp disconnected or broken) or shorted to ground the inverter will attempt to strike the lamp for number of cycles. After about 800 milliseconds without success the inverter will shutdown. In order to restart the inverter it is necessary to toggle the SLEEP input or cycle the V_{IN1} input supply.



PanelMatch™

LXMG1626-12-64

12V Dual 6W CCFL Programmable Inverter Module

PRODUCTION DATASHEET

NOTES

PRODUCTION DATA – Information contained in this document is proprietary to Microsemi and is current as of publication date. This document may not be modified in any way without the express written consent of Microsemi. Product processing does not necessarily include testing of all parameters. Microsemi reserves the right to change the configuration and performance of the product and to discontinue product at any time.