

DESCRIPTION

The LXMG1813-12-6xS is a Single Output 6W CCFL (Cold Cathode Fluorescent Lamp) Inverter Module designed for the driving LCD backlight lamps for panels in the range of 3.9" to 15".

Utilizing the full-bridge drive topology capabilities of the Microsemi's highly integrated LX1697 CCFL backlight controller the inverter allows a wider input voltage range (9V to 16.8V) and wider lamp output voltage range 390V to 790V compared to Microsemi's existing Direct Drive™ inverter solutions.

Also this 'S' version includes an additional input connector which links the inverter to a light sensor board (the LXMG1800_LS). So connected, the inverter is capable of automatically adjusting (VEasyLIT™) the brightness of the LCD display to ambient lighting conditions.

Automatic brightness control can extend the life of the display and save power (particularly important for battery powered products). For applications needing full manual control of lamp brightness (dimming) we recommend the LXMG1813-12-6x (non-S), which does not offer the light sensor input.

The maximum output current of the inverter is externally programmable over a range of 4mA to 7mA in 1mA steps to allow the inverter to properly match (PanelMatch™) to a wide array of LCD panel lamp current specifications. For lower input voltage requirements the LXMG1811-05-6x or -6xS will work from a 5V input supply.

Other benefits of the inverter's topology include stable fixed-frequency operation, secondary-side strike voltage regulation and both open/shorted lamp protection with fault timeout.

IMPORTANT: For the most current data, consult MICROSEMI's website: <http://www.microsemi.com>
Protected by U.S. Patents: 5,923, 129; 5,930,121; 6,198,234; Patents Pending

KEY FEATURES

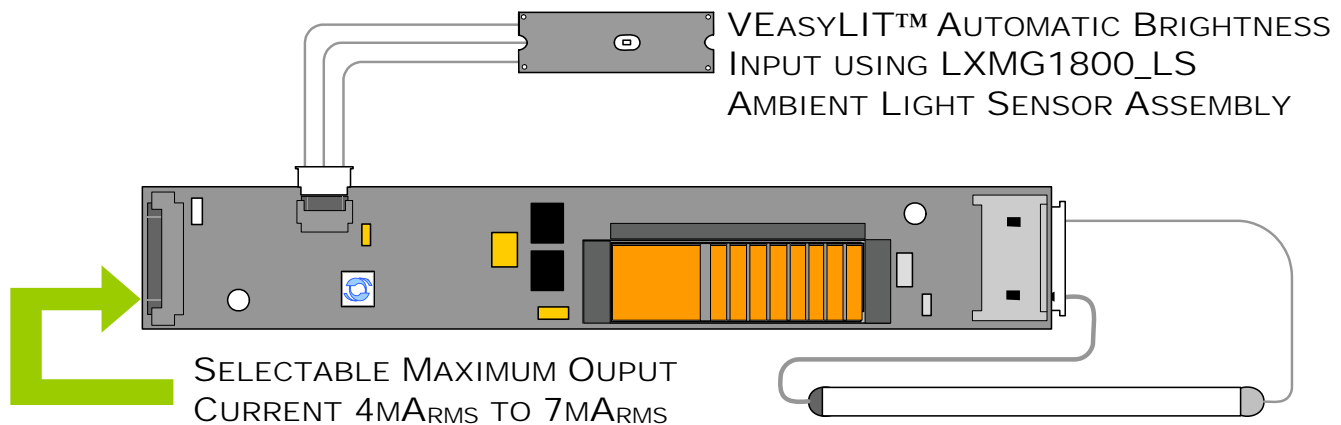
- Automatic Lamp Dimming Using External LXMG1800_LS Light Sensor Board Assembly
- Externally Programmable Maximum Output Current
- Wide Input Voltage Range
- Fixed Frequency Operation
- Output Short-Circuit Protection and Automatic Strike-Voltage Regulation and Timeout
- RangeMAX Wide Range Dimming (50:1+)
- Rated From -30°C to 80°C
- UL60950 Pending
- RoHS Compliant

APPLICATIONS

- Medical Instrument Displays
- Portable Instrumentation
- Desktop Displays
- Industrial Display Controls

BENEFITS

- Smooth, Flicker Free Full-Range Brightness Control
- Programmable Output Current Allows Inverter to Mate with a Wide Variety of LCD Panel's Specifications

PRODUCT HIGHLIGHT

PACKAGE ORDER INFO

PART NUMBER	OUTPUT CONNECTOR	INVERTER MATES DIRECTLY TO PANEL CONNECTORS
LXMG1813-12-61S	JST SM02(8.0)B-BHS-1-TB(LF)(SN), Yeon Ho 20015WR-05A00 or equivalent	JST BHR-03VS-1
LXMG1813-12-62S	JST SM02B-BHSS-1-TB(LF)(SN), Yeon Ho 35001WR-02A00 or equivalent	JST BHSR-02VS-1



PanelMatch™ VEasyLIT™ LXMG1813-12-6xS

12V 6W CCFL Programmable Inverter Module

PRODUCTION DATASHEET

ABSOLUTE MAXIMUM RATINGS

Input Signal Voltage (V_{IN}).....	-0.3V to 19V
Input Power	8W
Output Voltage, no load	1800V _{RMS}
Output Current	7.5mA _{RMS}
Output Power	6W
Input Signal Voltage (SLEEP Input)	-0.3V to V_{IN}
Input Signal Voltage (ALS_IN)	-0.3V to 5.5V
Analog Output (ALS_VCC external load current).....	-5mA
Ambient Operating Temperature, zero airflow.....	-30°C to 80°C
Storage Temperature Range.....	-40°C to 85°C

Note: Exceeding these ratings could cause damage to the device. All voltages are with respect to Ground. Currents are positive into, negative out of specified terminal.

RECOMMENDED OPERATING CONDITIONS (R.C.)

This module has been designed to operate over a wide range of input and output conditions. However, best efficiency and performance will be obtained if the module is operated under the condition listed in the 'R.C.' column. Min. and Max. columns indicate values beyond which the inverter, although operational, may not function optimally.

Parameter	Symbol	Recommended Operating Conditions			Units
		Min	R.C.	Max	
Input Supply Voltage Range (Fully Regulated Lamp Current)	V_{IN}	9	12	16.8	V
Input Supply Voltage Range (Functional)		8.4	12	16.8	
Output Power	P_O		4.2	6.0	W
Lamp Operating Voltage	V_{LAMP}	390	590	790	V _{RMS}
Lamp Current (Full Brightness)	$I_{O(LAMP)}$	4		7	mA _{RMS}
Operating Ambient Temperature Range	T_A	-30		80	°C

ELECTRICAL CHARACTERISTICS

The following specifications apply over the recommended operating condition and ambient temperature of 0°C to 60°C except where otherwise noted; ALS_IN ≥ 2.3V, SLEEP ≥ 2.0V, VIN = 12V.

Parameter	Symbol	Test Conditions	LXMG1813-12-6xS			Units
			Min	Typ	Max	
OUTPUT PIN CHARACTERISTICS						
Full Lamp Current	$I_{L(MAX)}$	SET ₁ = Ground, SET ₂ = Ground	3.5	4.0	4.5	mA _{RMS}
Full Lamp Current	$I_{L(MAX)}$	SET ₁ = Ground, SET ₂ = Open	4.5	5.0	5.5	mA _{RMS}
Full Lamp Current	$I_{L(MAX)}$	SET ₁ = Open, SET ₂ = Ground	5.5	6.0	6.5	mA _{RMS}
Full Lamp Current	$I_{L(MAX)}$	SET ₁ = Open, SET ₂ = Open	6.5	7.0	7.5	mA _{RMS}
Full Lamp Current	$I_{L(MAX)}$	$V_{IN} = 9$ to 16.8V; SET ₁ = Open, SET ₂ = Ground	5.4	6.0	6.6	mA _{RMS}
Min. Average Lamp Current	$I_{L(MIN)}$	ALS_IN ≤ 0.9V, SET ₁ = SET ₂ = Ground, BRITE = floating; $I_{L(MIN)} = I_L * \sqrt{\text{Min Duty Ratio}}$		1.0		mA _{RMS}
Lamp Start Voltage	V_{LS}	-30°C < T_A < 80°C, $V_{IN} \geq 8.4V$	1400	1600		V _{RMS}
Operating Frequency	f_O		49.8	53	56.2	kHz
Burst Frequency	f_{BURST}	Output Burst Frequency	195	208	220	Hz



PanelMatch™ VEasyLIT™ LXMG1813-12-6xS

12V 6W CCFL Programmable Inverter Module

PRODUCTION DATASHEET

ELECTRICAL CHARACTERISTICS (CONTINUED)

The following specifications apply over the recommended operating condition and ambient temperature of 0°C to 60°C except where otherwise noted; $ALS_IN \geq 2.3V$, $\overline{SLEEP} \geq 2.0V$, $V_{IN} = 12V$.

Parameter	Symbol	Test Conditions	LXMG1813-12-6xS			Units
			Min	Typ	Max	
▶ BRITE INPUT						
Potentiometer Max Impedance	BRT _{POT}	Full Lamp Current	400	500		kΩ
Potentiometer Min Impedance		Minimum Lamp Current		0		kΩ
▶ SLEEP BAR INPUT						
RUN Mode	$V_{\overline{SLEEP}}$		2.0		V_{IN}	V
SLEEP Mode	$V_{\overline{SLEEP}}$		-0.3		0.8	V
▶ SET_{1,2} INPUT						
SET _{1,2} Low Threshold	V_L			0		V
Input Current	I_{SET}	$V_{SETx} = 0V$	-475	-510	-555	μA
▶ ALS (AMBIENT LIGHT SENSOR)						
ALS_VCC	ALS _{VCC}	$I_{LOAD} = 3mA$	4.8	5.1	5.5	V
▶ POWER CHARACTERISTICS						
Sleep Current	$I_{IN(MIN)}$	$\overline{SLEEP} \leq 0.8V$		10	20	μA
Run Current	I_{RUN}	SET ₁ = Open SET ₂ = Ground, $V_{LAMP} = 590V_{RMS}$		370		mA
Strike (Open Lamp)	T_{S_DWELL}		1.5	2	2.5	Sec
Supply Current under Fault condition	I_{FAULT}	Fault condition		8		mA
Typical Efficiency	η	SET ₁ = Open SET ₂ = Ground, $V_{LAMP} = 590V_{RMS}$	75	80		%

FUNCTIONAL PIN DESCRIPTION

CONN	PIN	DESCRIPTION
CN1 (Molex 53261-0871 or equivalent) mates with 51021-0800 housing, 50079-8100 pins. Mates with LX9501G input cable assembly		
CN1-1	V_{IN}	Main Input Power Supply ($9V \leq V_{IN} \leq 16.8V$)
CN1-2		
CN1-3	GND	Power Supply Return
CN1-4		
CN1-5	\overline{SLEEP}	ON/OFF Control. ($0V \leq \overline{SLEEP} \leq 0.8V = OFF$, $\overline{SLEEP} \geq 2.0V = ON$)
CN1-6	BRITE	Can be left open or connected to a 500k potentiometer to reduce brightness when the LXMG1800_LS is connected to CN3. Not recommended as brightness control voltage input.
CN1-7	SET ₁	SET ₁ MSB Connecting this pin to ground decreases the output current (see Table 1)
CN1-8	SET ₂	SET ₂ LSB Connecting this pin to ground decreases the output current (see Table 1)
CN2 (Molex 53261-0371 or equivalent) mates with 51021-0800 housing, 50079-8100 pins. Mates with LXMG1800_LS ALS Assembly		
CN2-1	ALS_VCC	Nominal 5.1V Supply for ALS Board Assembly. 3mA maximum output load
CN2-2	ALS_IN	Brightness Control Voltage input from light sensor board.
CN2-3	ASL_GND	ALS Board Power Supply Return.

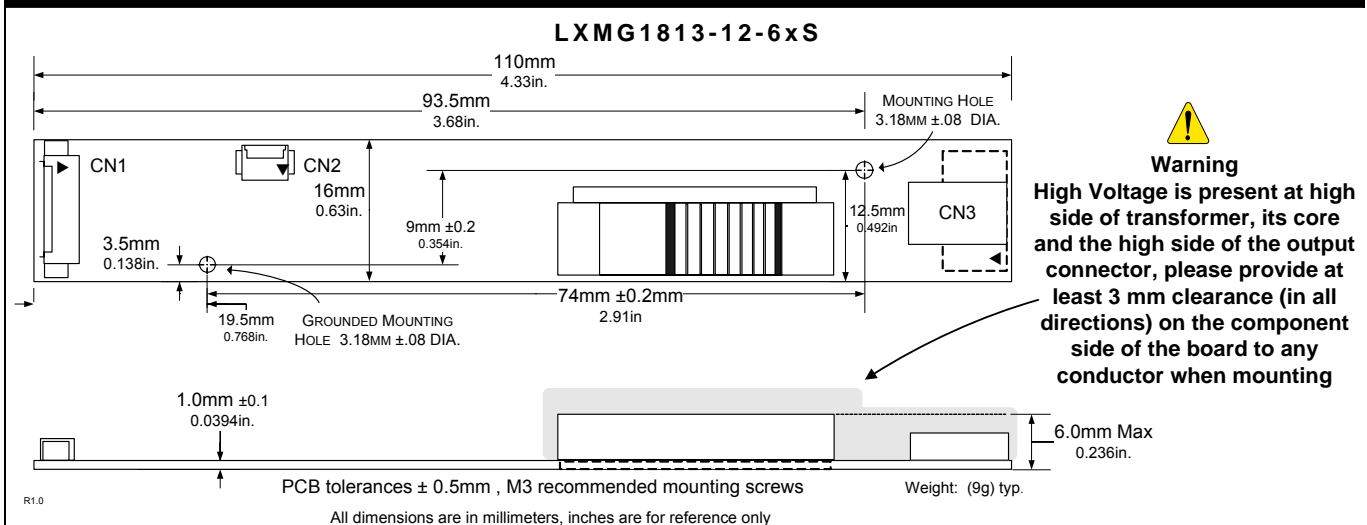
FUNCTIONAL PIN DESCRIPTION

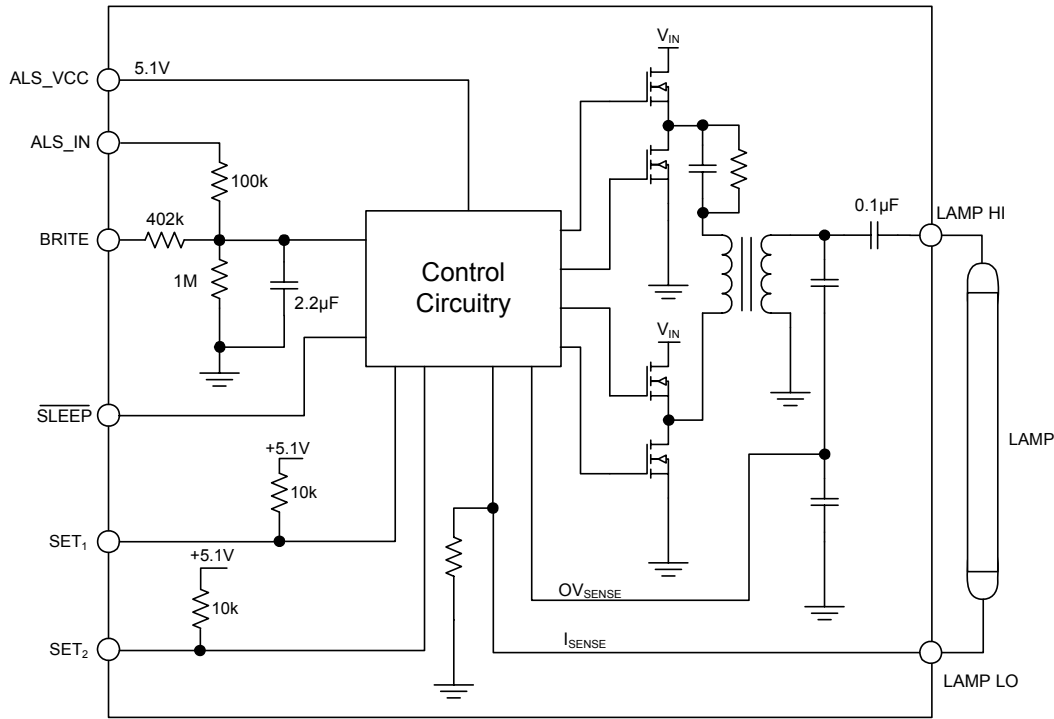
CONN	PIN	DESCRIPTION
CN3 for LXMG1813-12-61S and -62S (JST SM02(8.0)B-BHS-1-TB(LF)(SN) ; Yeon Ho 20015WR-05A00, SM02B-BHSS-1-TB(LF)(SN) ; Yeon Ho 35001WR-02A00) or equivalent		
CN3-1	V _{HI}	High voltage connection to high side of lamp. Connect to lamp terminal with shortest lead length. DO NOT connect to Ground.
CN3-2	V _{LO}	Connection to low side of lamp. Connect to lamp terminal with longer lead length. DO NOT connect to Ground

TABLE 1
OUTPUT CURRENT SETTINGS

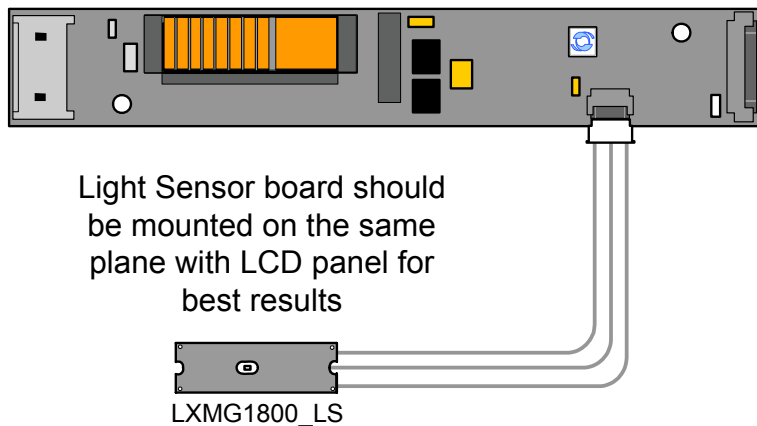
SET ₁ (Pin 7)	SET ₂ (Pin 8)	Nominal Output Current
Open*	Open*	7.0mA
Open*	Ground	6.0mA
Ground	Open*	5.0mA
Ground	Ground	4.0mA

* If driven by a logic signal it should be open collector or open drain only, not a voltage source.

PHYSICAL DIMENSIONS


SIMPLIFIED BLOCK DIAGRAM

VeasyLIT™ LXMG1800_LS APPLICATION
Key LXMG1800_LS Features

Small Size 9.5 x 31 x 2.5 mm
 Flush Mount on Sensor Side
 Board is Powered by Inverter
 User Customizable Light Gain
 Human Eye Light Response
 Flexible Mounting Location



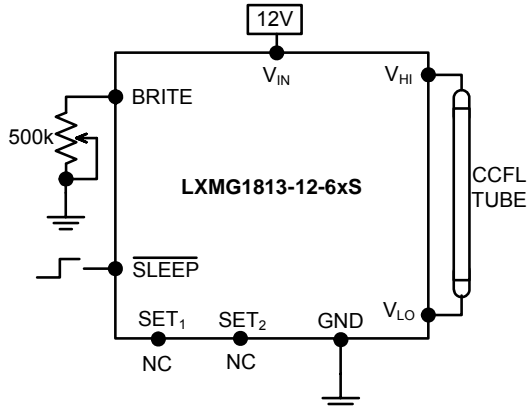
TYPICAL APPLICATION


Figure 1 – Brightness Control
(Output current set to maximum)

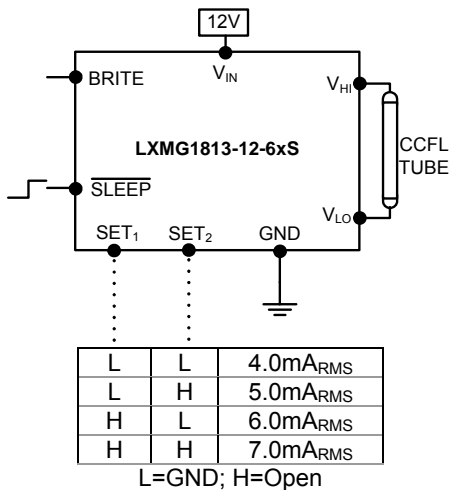


Figure 2 – Max Output Current
(SET₁ and SET₂ Inputs)

- It is recommended to use LXMG1813-12-6xS only with the LXMG1800_LS external light sensor assembly. A 500k potentiometer may be added to the inverter's BRITE input pin to allow a degree of manual override to the light sensor. Adjustment of the potentiometer will only dim the display further; it cannot increase the maximum brightness level set by the light sensor. If full manual control of dimming is required by the application we recommend the use of the LXMG1813-12-6x (non-S) version.
- If you need to turn the inverter ON/OFF remotely, connect to TTL logic signal to the SLEEP input.
- Connect V_{HI} to high voltage wire from the lamp. Connect V_{LO} to the low voltage wire (wire with thinner insulation). Never connect V_{LO} to circuit ground as this will defeat lamp current regulation. If both lamp wires have heavy high voltage insulation, connect the longest wire to V_{LO}. This wire is typically white.
- Use the SET₁ and SET₂ (see Figure 2) inputs to select the desired maximum output current. Using these two pins in combination allows the inverter to match a wide variety of panels from different manufacturers. Generally the best lamp lifetime correlates with driving the CCFL at the manufacture's nominal current setting. However the SET₁ and SET₂ inputs allow the user the flexibility to adjust the current to the maximum allowable output current to increase panel brightness at the expense of some reduced lamp life.
- Although the SET pins are designed such that just leaving them open or grounding them is all that is needed to set the output current, they can also be actively set. Using an open collector or open drain logic signal will allow you to reduce the lamp current for situations where greater dim range is required. Since the dim ratio is a factor of both the burst duty cycle and the peak output current, using this technique the effective dim ratio can be increased greater than the burst duty cycle alone. Conversely, the SET inputs could be used to overdrive the lamp temporarily to facilitate faster lamp warm up at initial lamp turn on. Of course any possible degradation on lamp life from such practices is the user's responsibility since not all lamps are designed to be overdriven.
- The inverter has a built-in fault timeout function. If the output is open (lamp disconnected or broken) the inverter will attempt to strike the lamp up to about two seconds, after which (without success) the inverter will shutdown. In this mode the inverter will draw about 8mA from V_{IN}. In order to restart the inverter it is necessary to toggle the sleep input or cycle the V_{IN} input supply.



PanelMatch™ VEasyLIT™ LXMG1813-12-6xS

12V 6W CCFL Programmable Inverter Module

PRODUCTION DATASHEET

NOTES

PRODUCTION DATA – Information contained in this document is proprietary to Microsemi and is current as of publication date. This document may not be modified in any way without the express written consent of Microsemi. Product processing does not necessarily include testing of all parameters. Microsemi reserves the right to change the configuration and performance of the product and to discontinue product at any time