

# High Reliability Hermetic Infrared Emitting Diode

## OP235, OP236 (TX, TXV)



### Features:

- TO-46 hermetically sealed package with lens
- Twice the power output of GaAs at same drive current
- Characterized to define infrared energy along mechanical axis of device
- Narrow beam angle
- Processed to MIL-PRF-19500.

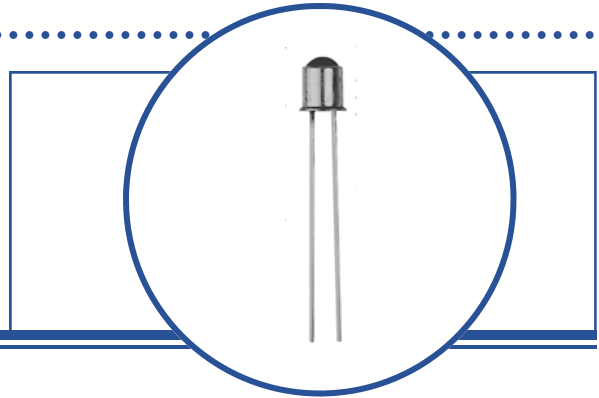

### Description:

Each device in this series is a gallium aluminum arsenide (GaAlAs) infrared emitting diode, mounted in a hermetic metal TO-46 housing with 0.50" (12.70 mm) leads. The gallium aluminum arsenide feature provides a higher radiated output than gallium arsenide at the same forward current, while the 890 nm wavelength closely matches the spectral response of silicon phototransistors. Devices have lens cans that provide an 18° beam angle between half power points, which facilitates the easy design of beam interrupt applications with the OP804 and OP805 series of high reliability phototransistors.

*TX and TXV devices are processed to OPTEK's military screening program patterned after MIL-PRF-19500. After 100% screening, Group A and B are performed on every lot and a Group C test is performed every six months.*

Please refer to Application Bulletins 208 and 210 for additional design information and reliability (degradation) data.

Contact your local representative or OPTEK for more information.

### Applications:

- Non-contact reflective object sensor
- Assembly line automation
- Machine automation
- Machine safety
- End of travel sensor
- Door sensor
- Military and harsh environments

Part Number	LED Peak Wavelength	Output Power (mW/cm <sup>2</sup> ) Min / Max	I <sub>F</sub> (mA) Typ / Max	Total Beam Angle	Lead Length
OP235TX	890 nm	1.5 / NA	50 / 100	18°	0.50"
OP235TXV					
OP236TX		3.5 / NA			
OP236TXV					

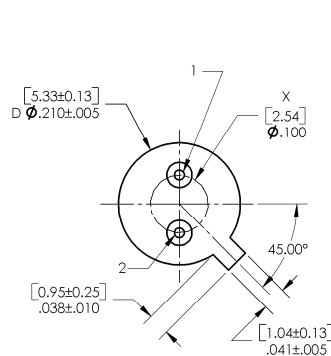
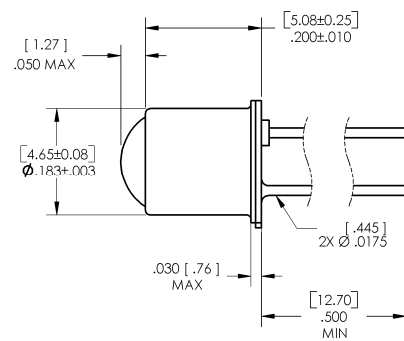

Pin #	LED	Sensor
1	Anode	Collector / Cathode
2	Cathode	Emitter / Anode

OPTEK reserves the right to make changes at any time in order to improve design and to supply the best product possible.

# High Reliability Hermetic Infrared Emitting Diode

## OP235, OP236 (TX, TXV)



### Absolute Maximum Ratings ( $T_A = 25^\circ\text{C}$ unless otherwise noted)

Storage Temperature Range	-65° C to +150° C
Operating Temperature Range	-55° C to +125° C
Reverse Voltage	2.0 V
Forward DC Current	100 mA
Lead Soldering Temperature [1/16 inch (1.6 mm) from case for 5 seconds with soldering iron]	260° C <sup>(1)</sup>
Power Dissipation	200 mW <sup>(2)</sup>

### Electrical Characteristics ( $T_A = 25^\circ\text{C}$ unless otherwise noted)

SYMBOL	PARAMETER	MIN	TYP	MAX	UNITS	TEST CONDITIONS
$E_{E(APT)}$	Apertured Radiant Incidence OP235 (TX, TXV) OP236 (TX, TXV)	1.5 3.5	- -	- -	mW/cm <sup>2</sup>	$I_F = 100\text{ mA}$
$V_F$	Forward Voltage	1.1 1.3 0.9	- - -	2.0 2.2 1.8	V	$I_F = 100\text{ mA}$ $I_F = 100\text{ mA}, T_A = -55^\circ\text{C}$ $I_F = 100\text{ mA}, T_A = 100^\circ\text{C}$
$I_R$	Reverse Current	-	-	100	$\mu\text{A}$	$V_R = 2.0\text{ V}$
$\lambda_P$	Wavelength at Peak Emission	-	890	-	nm	$I_F = 100\text{ mA}$
$\beta$	Spectral Bandwidth between Half Power Points	-	50	-	nm	$I_F = 100\text{ mA}$
$\theta_{HP}$	Emission Angle at Half Power Points	-	18	-	Degree	$I_F = 100\text{ mA}$

#### Notes:

1. RMA flux is recommended. Duration can be extended to 10 seconds maximum when flow soldering.
2. Derate linearly 2.00 mW/° C above 25° C.
3.  $E_{E(APT)}$  is a measurement of the average radiant intensity within the cone formed by the measurement surface, a radius of 1.429" (36.30 mm) measured from the lens side of the tab to the sensing surface and a sensing surface of 0.250" (6.35 mm) in diameter forming a 10° cone.  $E_{E(APT)}$  is not necessarily uniform within the measured area.

OPTEK reserves the right to make changes at any time in order to improve design and to supply the best product possible.

### OP235, OP236 (TX, TXV)

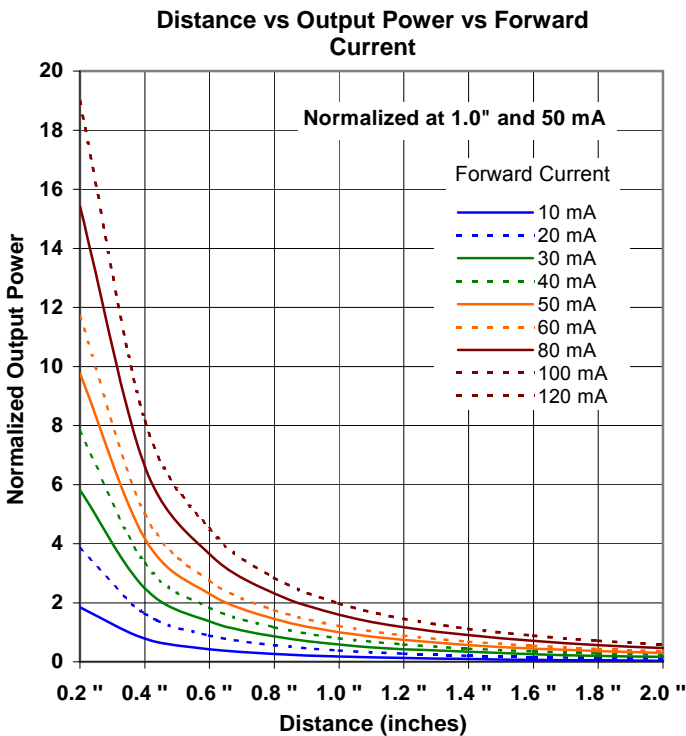
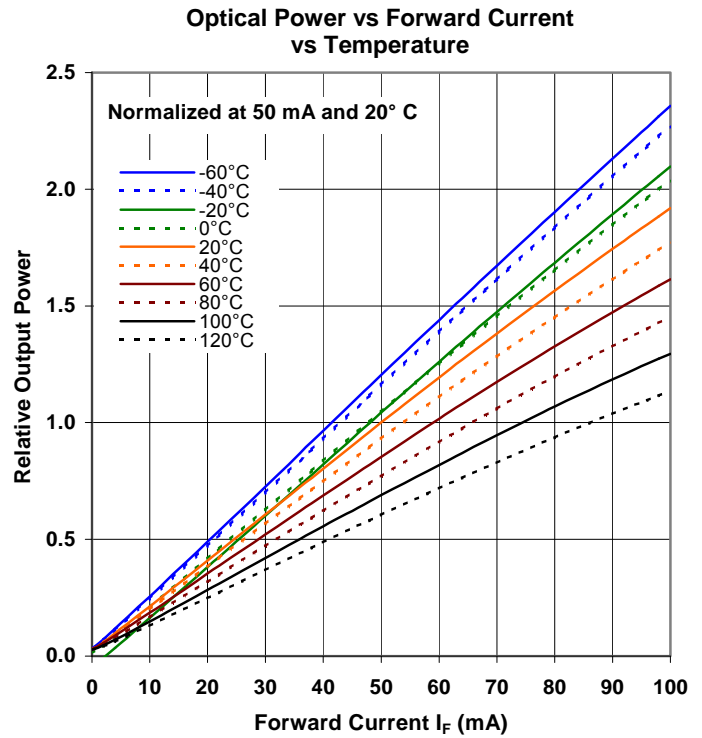
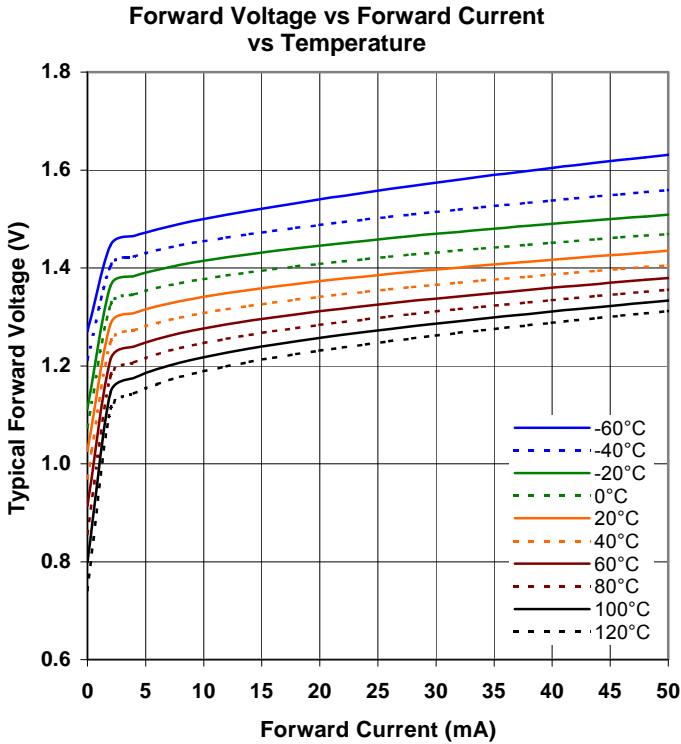

OPTEK reserves the right to make changes at any time in order to improve design and to supply the best product possible.