

## High Power Infrared Emitting Diode, RoHS Compliant, 940 nm, GaAlAs/GaAs

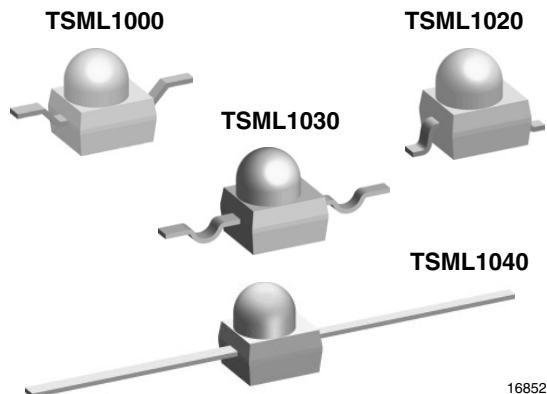

### FEATURES

- Package type: surface mount
- Package form: GW, RGW, yoke, axial
- Dimensions (L x W x H in mm): 2.5 x 2 x 2.7
- Peak wavelength:  $\lambda_p = 940$  nm
- High radiant power
- High radiant intensity
- Angle of half intensity:  $\phi = \pm 12^\circ$
- Low forward voltage
- Suitable for high pulse current operation
- Good spectral matching with Si photodetectors
- Versatile terminal configurations
- Package matches with detector TEMT1000
- Floor life: 168 h, MSL 3, acc. J-STD-020
- Lead (Pb)-free component in accordance with RoHS 2002/95/EC and WEEE 2002/96/EC



**RoHS**  
COMPLIANT

### DESCRIPTION

TSML1000 is an infrared, 940 nm emitting diode in GaAlAs/GaAs with high radiant power molded in a clear, untinted plastic package (with lens) for surface mounting (SMD).

### APPLICATIONS

- For remote control
- Punched tape readers
- Encoder
- Photointerrupters

PRODUCT SUMMARY				
COMPONENT	$I_e$ (mW/sr)	$\phi$ (deg)	$\lambda_p$ (nm)	$t_r$ (ns)
TSML1000	7	$\pm 12$	940	800
TSML1020	7	$\pm 12$	940	800
TSML1030	7	$\pm 12$	940	800
TSML1040	7	$\pm 12$	940	800

**Note**

Test conditions see table "Basic Characteristics"

ORDERING INFORMATION			
ORDERING CODE	PACKAGING	REMARKS	PACKAGE FORM
TSML1000	Tape and reel	MOQ: 1000 pcs, 1000 pcs/reel	Reverse gullwing
TSML1020	Tape and reel	MOQ: 1000 pcs, 1000 pcs/reel	Gullwing
TSML1030	Tape and reel	MOQ: 1000 pcs, 1000 pcs/reel	Yoke
TSML1040	Bulk	MOQ: 1000 pcs, 1000 pcs/bulk	Axial leads

**Note**

MOQ: minimum order quantity

ABSOLUTE MAXIMUM RATINGS				
PARAMETER	TEST CONDITION	SYMBOL	VALUE	UNIT
Reverse voltage		$V_R$	5	V
Forward current		$I_F$	100	mA
Peak forward current	$t_p/T = 0.5, t_p = 100 \mu s$	$I_{FM}$	200	mA
Surge forward current	$t_p = 100 \mu s$	$I_{FSM}$	1.0	A



# TSML1000, TSML1020, TSML1030, TSML1040

High Power Infrared Emitting Diode, Vishay Semiconductors  
RoHS Compliant, 940 nm, GaAlAs/GaAs

ABSOLUTE MAXIMUM RATINGS				
PARAMETER	TEST CONDITION	SYMBOL	VALUE	UNIT
Power dissipation		$P_V$	190	mW
Junction temperature		$T_j$	100	°C
Operating temperature range		$T_{amb}$	- 40 to + 85	°C
Storage temperature range		$T_{stg}$	- 40 to + 100	°C
Soldering temperature	$t \leq 5$ s	$T_{sd}$	< 260	°C
Thermal resistance junction/ambient	Soldered on PCB, pad dimensions: 4 mm x 4 mm	$R_{thJA}$	400	°C

**Note**

$T_{amb} = 25$  °C, unless otherwise specified

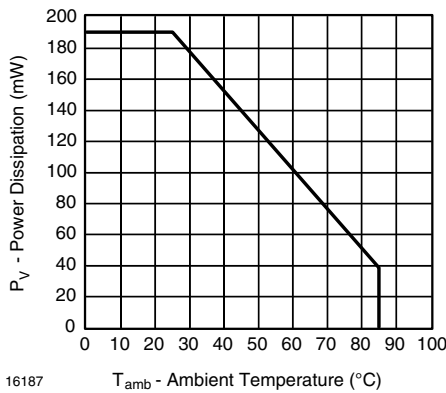

Fig. 1 - Power Dissipation Limit vs. Ambient Temperature



Fig. 2 - Forward Current vs. Ambient Temperature

BASIC CHARACTERISTICS						
PARAMETER	TEST CONDITION	SYMBOL	MIN.	TYP.	MAX.	UNIT
Forward voltage	$I_F = 20$ mA, $t_p = 20$ ms	$V_F$		1.2	1.5	V
	$I_F = 1$ A, $t_p = 100$ $\mu$ s	$V_F$		2.6		V
Temperature coefficient of $V_F$	$I_F = 1$ mA	$TK_{V_F}$		- 1.8		mV/K
Reverse current	$V_R = 5$ V	$I_R$			10	$\mu$ A
Junction capacitance	$V_R = 0$ V, $f = 1$ MHz, $E = 0$	$C_j$		25		pF
Radiant intensity	$I_F = 20$ mA, $t_p = 20$ ms	$I_e$	3	7	15	mW/sr
Radiant power	$I_F = 100$ mA, $t_p = 20$ ms	$\phi_e$		35		mW
Temperature coefficient of $\phi_e$	$I_F = 20$ mA	$TK_{\phi_e}$		- 0.6		%/K
Angle of half intensity		$\varphi$		$\pm 12$		deg
Peak wavelength	$I_F = 100$ mA	$\lambda_p$		940		nm
Spectral bandwidth	$I_F = 100$ mA	$\Delta\lambda$		50		nm
Temperature coefficient of $\lambda_p$	$I_F = 100$ mA	$TK_{\lambda_p}$		0.2		nm/K
Rise time	$I_F = 100$ mA	$t_r$		800		ns
Fall time	$I_F = 100$ mA	$t_f$		800		ns
Virtual source diameter		$d$		1.2		mm

**Note**

$T_{amb} = 25$  °C, unless otherwise specified

## BASIC CHARACTERISTICS

$T_{amb} = 25\text{ }^{\circ}\text{C}$ , unless otherwise specified

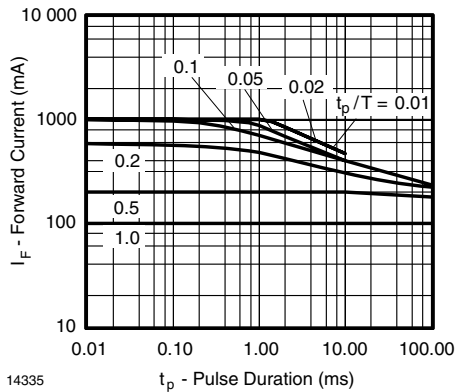

Fig. 3 - Pulse Forward Current vs. Pulse Duration

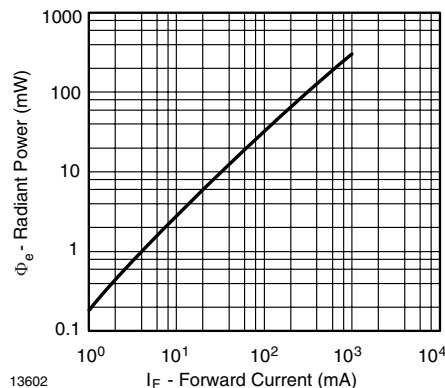

Fig. 6 - Radiant Power vs. Forward Current

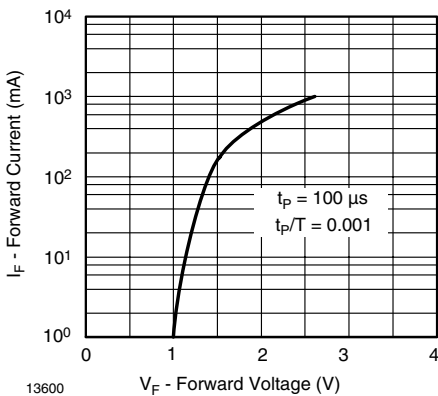

Fig. 4 - Forward Current vs. Forward Voltage

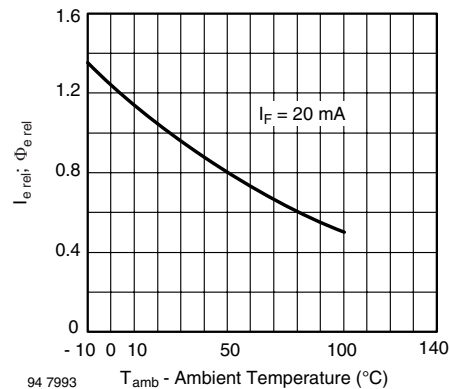

Fig. 7 - Relative Radiant Intensity/Power vs. Ambient Temperature

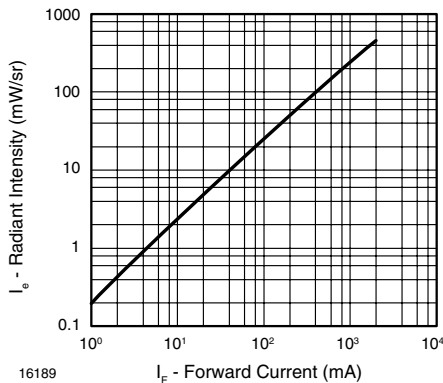

Fig. 5 - Radiant Intensity vs. Forward Current

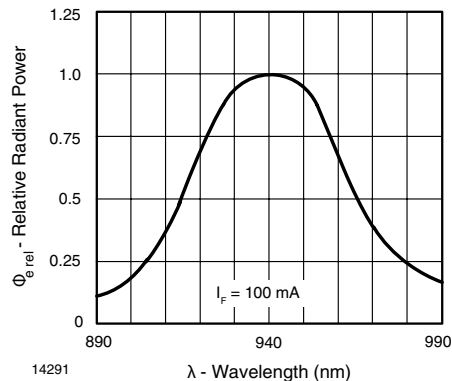

Fig. 8 - Relative Radiant Power vs. Wavelength



# TSML1000, TSML1020, TSML1030, TSML1040

High Power Infrared Emitting Diode, Vishay Semiconductors  
RoHS Compliant, 940 nm, GaAlAs/GaAs

## REFLOW SOLDER PROFILE

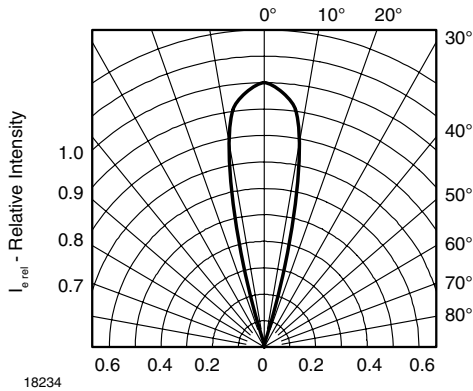

Fig. 9 - Relative Radiant Intensity vs. Angular Displacement

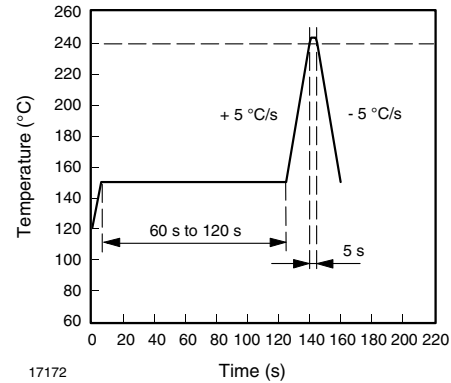

Fig. 10 - Lead Tin (SnPb) Reflow Solder Profile

## PRECAUTIONS FOR USE

### 1. Over-current-proof

Customer must apply resistors for protection, otherwise slight voltage shift will cause big current change (burn out will happen).

### 2. Storage

- 2.1 Storage temperature and rel. humidity conditions are: 5 °C to 35 °C, R.H. 60 %.
- 2.2 Floor life must not exceed 168 h, acc. to JEDEC level 3, J-STD-020.  
Once the package is opened, the products should be used within a week. Otherwise, they should be kept in a damp proof box with desiccant.  
Considering tape life, we suggest to use products within one year from production date.
- 2.3 If opened more than one week in an atmosphere 5 °C to 35 °C, R.H. 60 %, devices should be treated at 60 °C  $\pm$  5 °C for 15 h.
- 2.4 If humidity indicator in the package shows pink color (normal blue), then devices should be treated with the same conditions as 2.3.

# TSML1000, TSML1020, TSML1030, TSML1040



Vishay Semiconductors High Power Infrared Emitting Diode,  
RoHS Compliant, 940 nm, GaAlAs/GaAs

## PACKAGE DIMENSIONS in millimeters: TSML1000

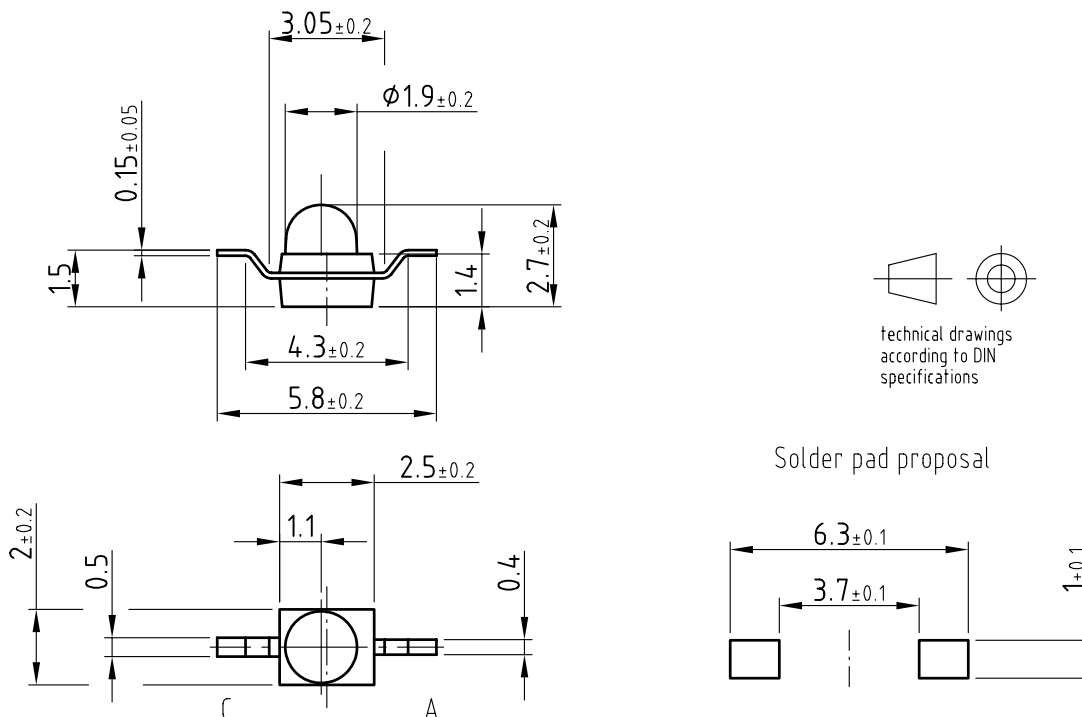

Drawing-No.: 6.544-5326.02-4

Issue: 3; 02.04.03

16159

## PACKAGE DIMENSIONS in millimeters: TSML1020

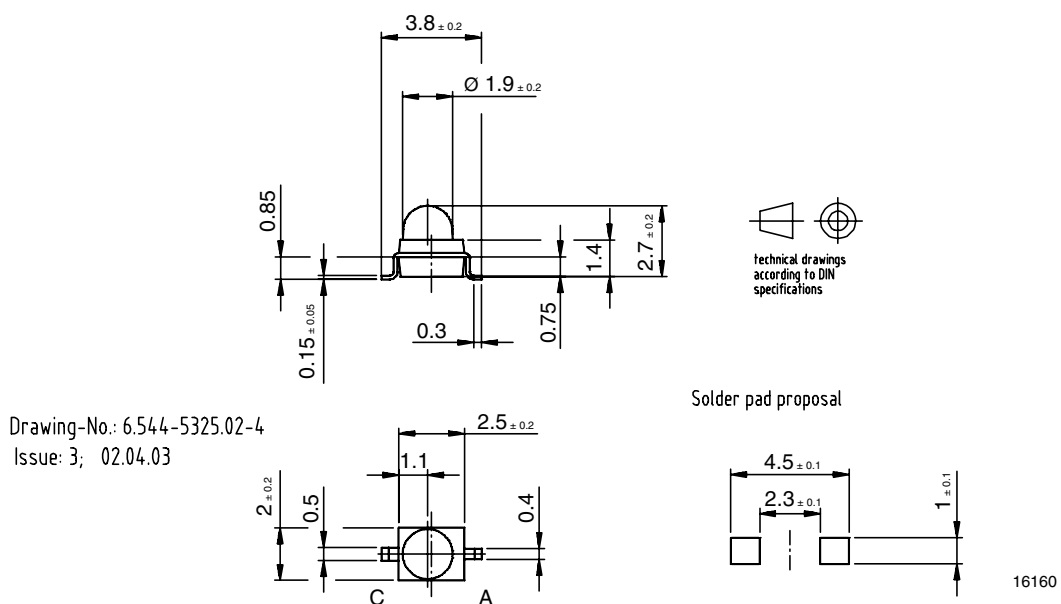

Drawing-No.: 6.544-5325.02-4

Issue: 3; 02.04.03

16160



# TSML1000, TSML1020, TSML1030, TSML1040

High Power Infrared Emitting Diode, Vishay Semiconductors  
RoHS Compliant, 940 nm, GaAlAs/GaAs

## PACKAGE DIMENSIONS in millimeters: TSML1030

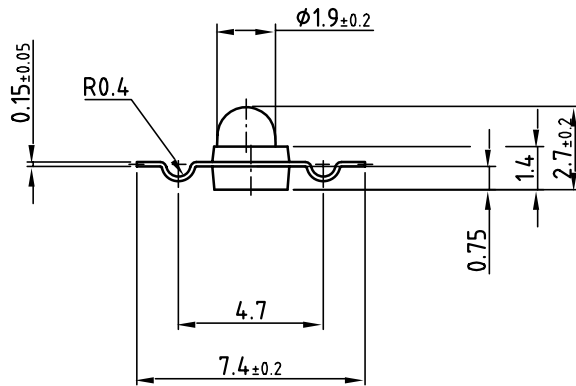

Drawing-No.: 6.544-5329.01-4

Issue: 4; 08.05.03

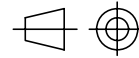

technical drawings  
according to DIN  
specifications

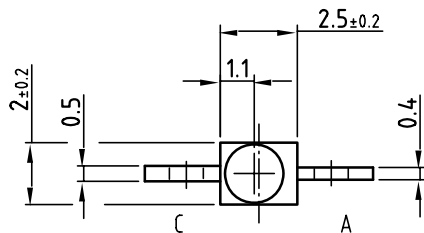

Solder pad proposal

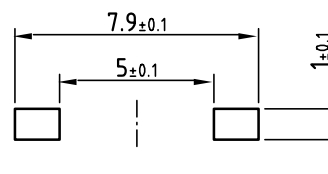

16228

## PACKAGE DIMENSIONS in millimeters: TSML1040

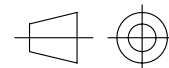
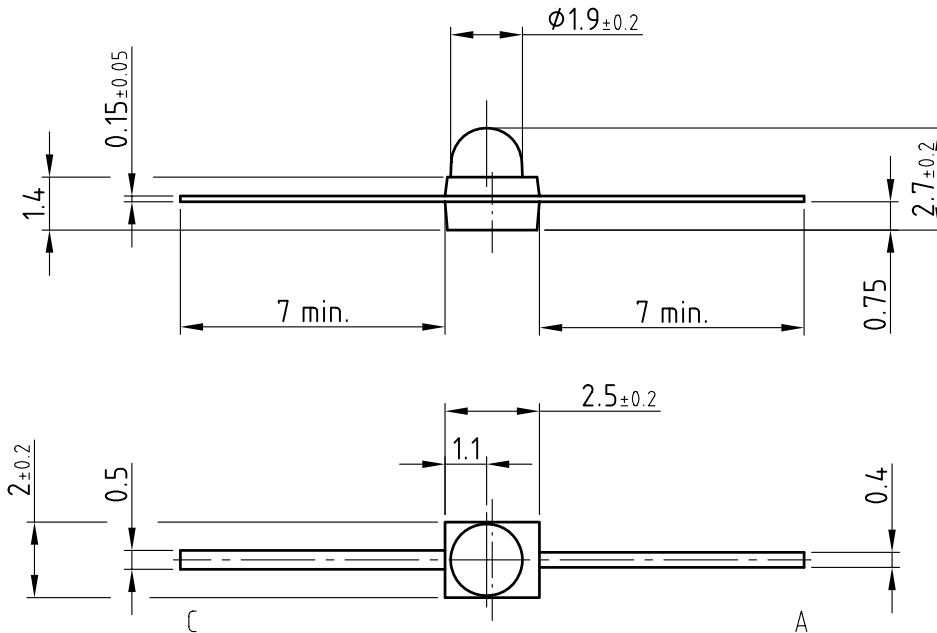

technical drawings  
according to DIN  
specifications

Drawing-No.: 6.544-5339.02-4

Issue: 3; 02.04.03

16760

# TSML1000, TSML1020, TSML1030, TSML1040

Vishay Semiconductors High Power Infrared Emitting Diode,  
RoHS Compliant, 940 nm, GaAlAs/GaAs



## REEL DIMENSIONS in millimeters

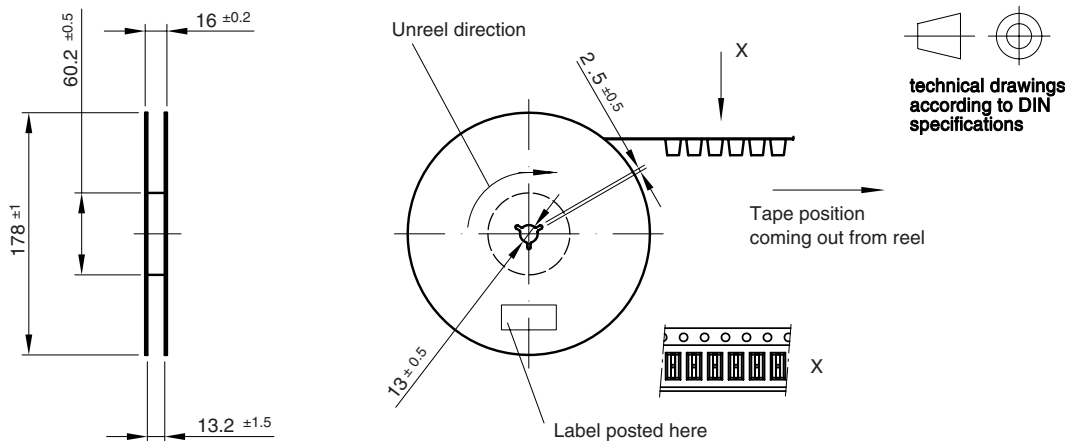

Leader and trailer tape:

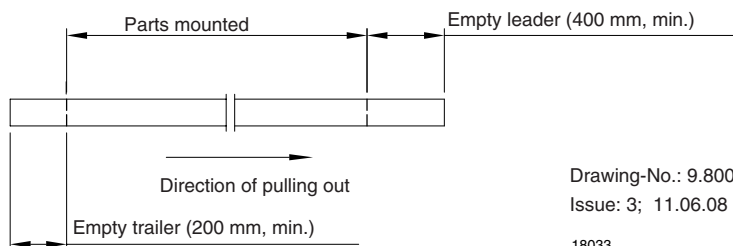

Drawing-No.: 9.800-5080.01-4

Issue: 3; 11.06.08

18033

## TAPING DIMENSIONS in millimeters: TSML1000

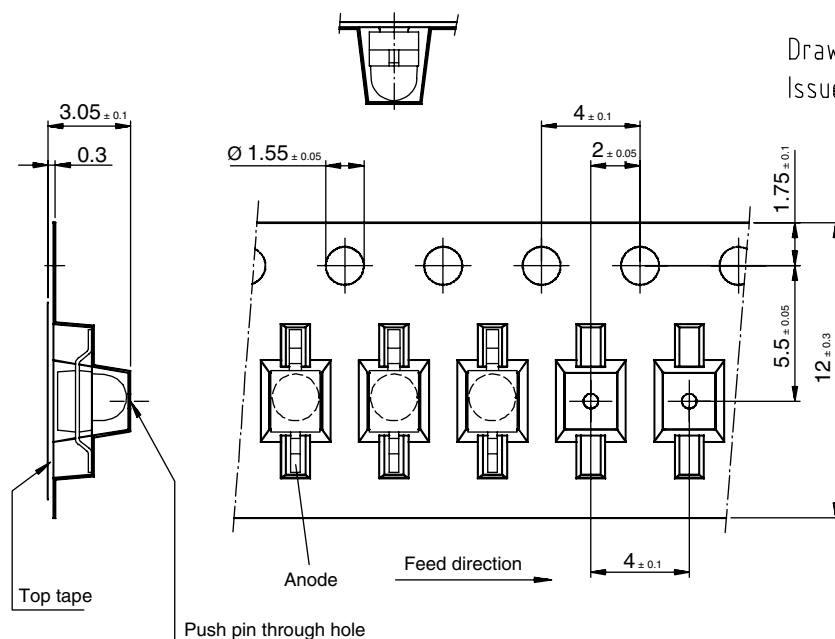

Drawing-No.: 9.700-5268.01-4

Issue: 2; 22.11.02

Quantity per reel: 1000 pcs or 5000 pcs

18030



# TSML1000, TSML1020, TSML1030, TSML1040

High Power Infrared Emitting Diode, Vishay Semiconductors  
RoHS Compliant, 940 nm, GaAlAs/GaAs

## TAPING DIMENSIONS in millimeters: TSML1020

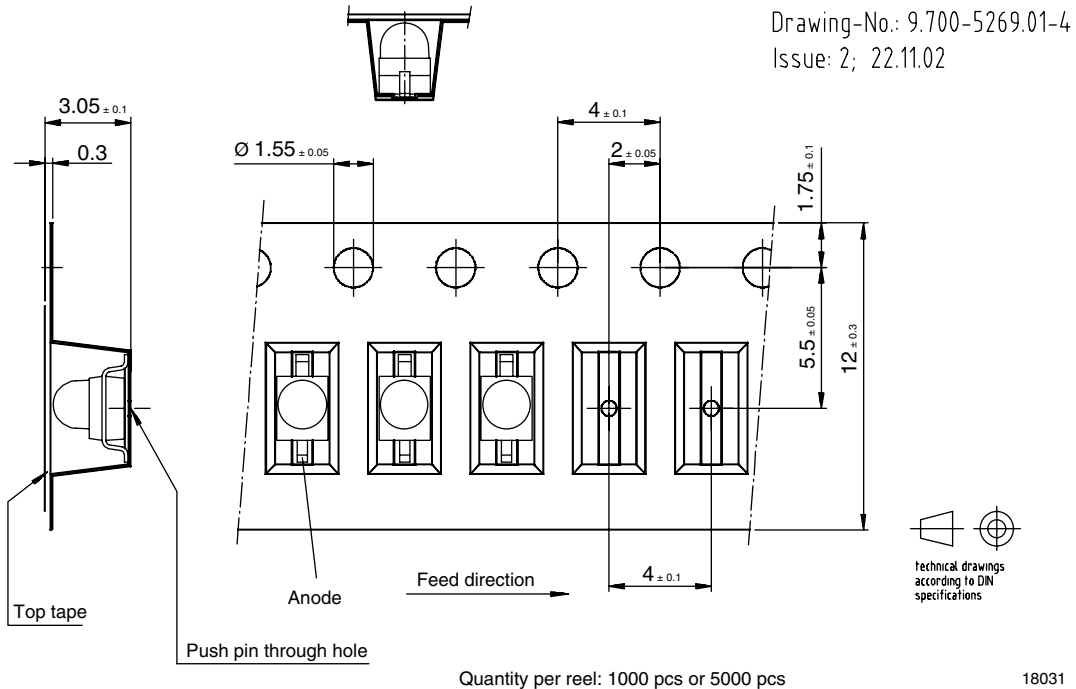

## TAPING DIMENSIONS in millimeters: TSML1030

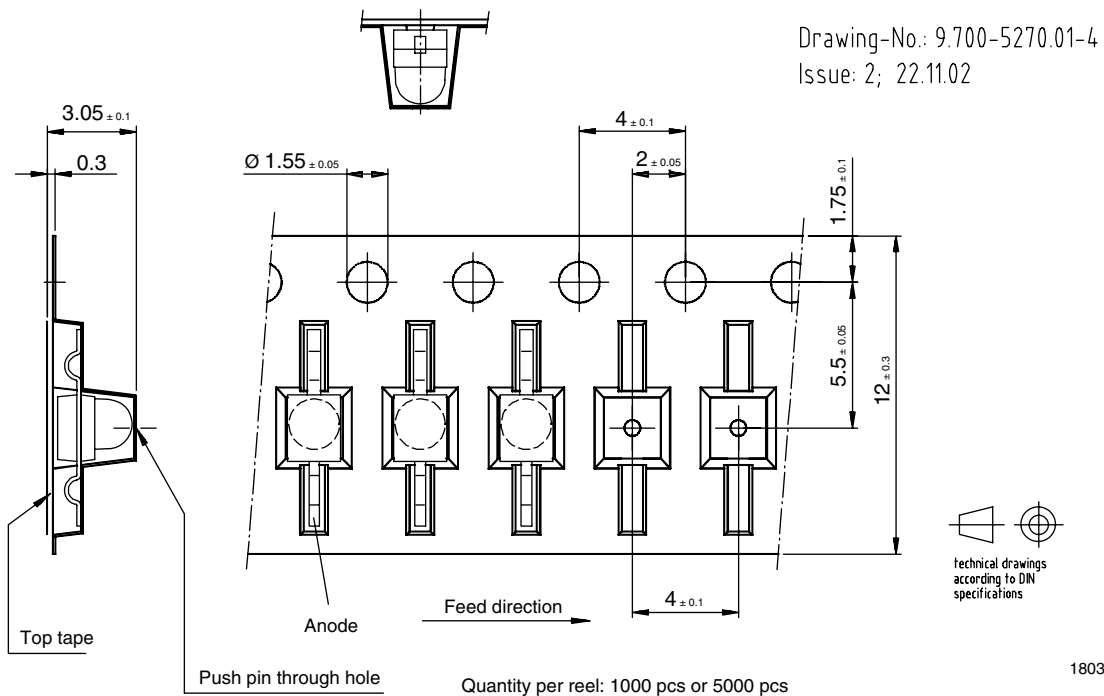





## Disclaimer

ALL PRODUCT, PRODUCT SPECIFICATIONS AND DATA ARE SUBJECT TO CHANGE WITHOUT NOTICE TO IMPROVE RELIABILITY, FUNCTION OR DESIGN OR OTHERWISE.

Vishay Intertechnology, Inc., its affiliates, agents, and employees, and all persons acting on its or their behalf (collectively, "Vishay"), disclaim any and all liability for any errors, inaccuracies or incompleteness contained in any datasheet or in any other disclosure relating to any product.

Vishay makes no warranty, representation or guarantee regarding the suitability of the products for any particular purpose or the continuing production of any product. To the maximum extent permitted by applicable law, Vishay disclaims (i) any and all liability arising out of the application or use of any product, (ii) any and all liability, including without limitation special, consequential or incidental damages, and (iii) any and all implied warranties, including warranties of fitness for particular purpose, non-infringement and merchantability.

Statements regarding the suitability of products for certain types of applications are based on Vishay's knowledge of typical requirements that are often placed on Vishay products in generic applications. Such statements are not binding statements about the suitability of products for a particular application. It is the customer's responsibility to validate that a particular product with the properties described in the product specification is suitable for use in a particular application. Parameters provided in datasheets and/or specifications may vary in different applications and performance may vary over time. All operating parameters, including typical parameters, must be validated for each customer application by the customer's technical experts. Product specifications do not expand or otherwise modify Vishay's terms and conditions of purchase, including but not limited to the warranty expressed therein.

Except as expressly indicated in writing, Vishay products are not designed for use in medical, life-saving, or life-sustaining applications or for any other application in which the failure of the Vishay product could result in personal injury or death. Customers using or selling Vishay products not expressly indicated for use in such applications do so at their own risk and agree to fully indemnify and hold Vishay and its distributors harmless from and against any and all claims, liabilities, expenses and damages arising or resulting in connection with such use or sale, including attorneys fees, even if such claim alleges that Vishay or its distributor was negligent regarding the design or manufacture of the part. Please contact authorized Vishay personnel to obtain written terms and conditions regarding products designed for such applications.

No license, express or implied, by estoppel or otherwise, to any intellectual property rights is granted by this document or by any conduct of Vishay. Product names and markings noted herein may be trademarks of their respective owners.