

FIBER OPTIC TRANSMITTING MODULE

TOTX179L

FIBER OPTIC TRANSMITTING MODULE FOR DIGITAL AUDIO EQUIPMENT

- Conform to JEITA Standard CP-1201 (For Digital Audio Interfaces including Fiber Optic inter-connections).
- TTL Interface.
- LED is driven by differential circuit.
- A Self-tapping hole for easy attachment to the panel of Audio Equipments.
- Shutter system

Unit : mm

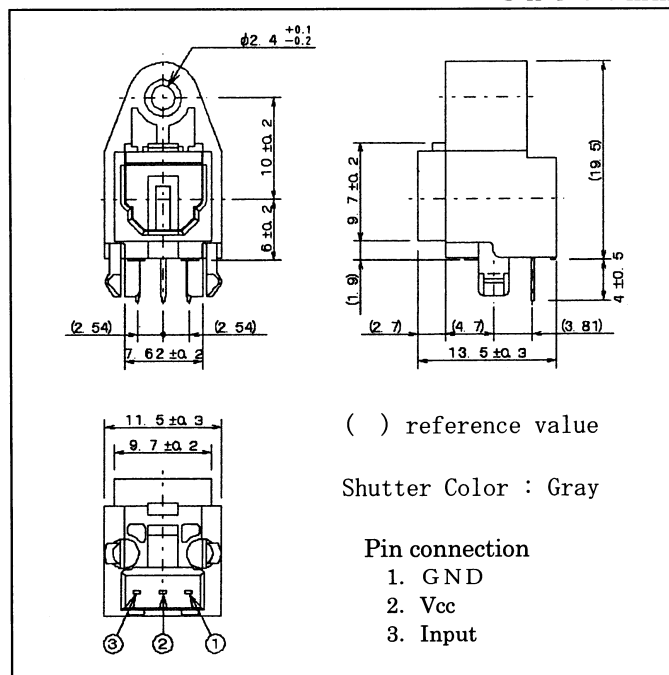

1. Maximum Ratings (Ta=25°C)

ITEM	SYMBOL	RATING	UNIT
Storage Temperature	Tstg	-40 to 70	°C
Operating Temperature	Topr	-20 to 70	°C
Supply Voltage	Vcc	-0.5 to 7	V
Input Voltage	VIN	-0.5 to Vcc+0.5	mA
Soldering Temperature	Tsol	260 ⁽¹⁾	°C

Note ⁽¹⁾ Soldering time ≤ 10 seconds. (At a distance of 1mm from the package)

2. Recommended Operating Conditions

ITEM	SYMBOL	MIN.	TYP.	MAX.	UNIT
Supply Voltage	Vcc	4.75	5.00	5.25	V
High Level Input Voltage	V _{IH}	2.0	—	Vcc	V
Low Level Input Voltage	V _{IL}	0	—	0.8	V

Handing precaution : The LED's used in this product contain GaAs (Gallium Arsenide). Care must be taken to protect the safety of people and the environment when scrapping or terminal processing.

3. Electrical and Optical Characteristics (Ta=25°C, Vcc=5V)

ITEM	SYMBOL	CONDITION	MIN.	TYP.	MAX.	UNIT
Date Rate		NRZ code ⁽²⁾	DC	—	12.8	Mb/s
Transmission Distance		Using APF ⁽³⁾ and TORX179L	0.2	—	5	m
Pulse Width Distortion ⁽⁴⁾	Δtw	Pulse Width 78ns Pulse Cycle 156ns Using TORX179L CL=10pF	-25	—	25	ns
Fiber Optic Power ⁽⁵⁾	Pf		-21	—	-15	dBm
Center Emission Wavelength	λc		630	650	670	nm
Delay Time (L to H)	tpLH	With TORX179L	—	100	250	ns
Delay Time (H to L)	tpHL	Fiber length 1m	—	100	250	ns
Current Consumption	Icc		—	15	20	mA
High Level Input Voltage	V _{IH}		2.0	—	—	V
Low Level Input Voltage	V _{IL}		—	—	0.8	V

- Note ⁽²⁾ LED is on when input signal is high level, it is off when low level.
 The duty factor must be kept 25 to 75%.
⁽³⁾ All Plastic Fiber (970/1000 μm)
⁽⁴⁾ Between input of TOTX179L and output of TORX179L.
⁽⁵⁾ Measure with a standard optical fiber. Peak value.

4. Mechanical Characteristics (Ta=25°C)

ITEM	CONDITION	MIN.	TYP.	MAX.	UNIT
Mating force	Using TOCP172, Initial value	—	—	39.2	N
Unmating force	Using TOCP172, Initial value	5.9	—	39.2	N
Torque for Self-Tap	Using self-tapping screw (M3×8)	58.8	—	98	N·cm

5. Application Circuit

Fiber optic connector insertion side

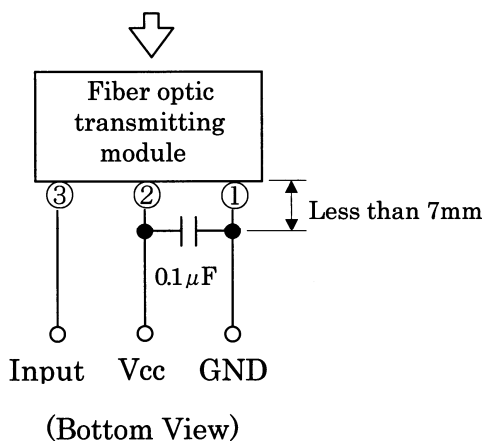

6. Applicable optical fiber with fiber optic connectors.

TOCP172-□□B

7. Foot Layout (reference)

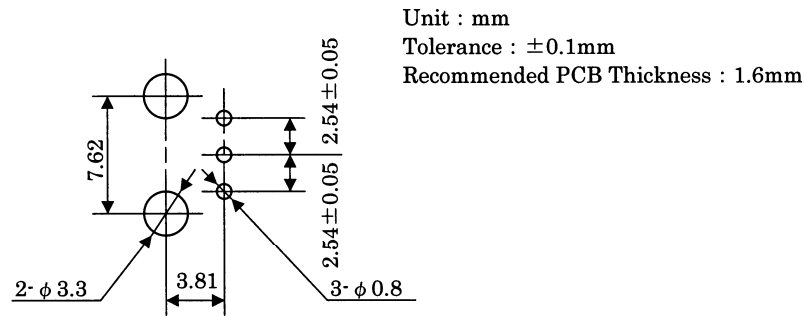

8. Precaution on Use

(1) Maximum Rating

The maximum ratings are the limit values which must not be exceeded during operation of device. None of these rating value must not be exceeded. If the maximum rating value is exceeded, the characteristics of devices may never be restored. In extreme cases, the device may be permanently damages.

(2) Lifetime of light emitters

If an optical module is used for a long period of time, degeneration in the characteristics will mostly be due to a lowering of the fiber output power (Pf). This is caused by the degradation of the optical output of the LED's used as the light source. The cause of degradation of the optical output of the LED's may be defects in wafer crystallization or mold resin stress.

The detailed causes are, however, not clear.

The lifetime of light emitters is greatly influenced by the operating conditions and the environment in which it is used as well as the lifetime characteristics unique to the device type. Thus, when a light emitting device and its operating conditions, Toshiba recommends that lifetime characteristics be checked.

Depending on the environment conditions, Toshiba recommend that maintenance such as regular checks of the amount of optical output in accordance with the condition of operating environment.

(3) Soldering

Optical modules are comprised of internal semiconductor devices. However, in principle, optical modules are optical components. During soldering, ensure that flux dose not contact with the emitting surface or detecting surface. Also ensure that proper flux removal is conducted after soldering.

Some optical modules come with protective cap. The protective cap is used to avoid malfunction when the optical module is not in use. Note that it is not dust or waterproof.

As mentioned before, optical modules are optical components. Thus, in principle, soldering where there may be flux residue or flux removal after soldering is not recommended.

Toshiba recommend that soldering be performed without the optical module mounted on the board. Then, after the board has been cleaned, the optical module should be soldered on to the board manually.

If the optical module cannot be soldered manually, use non-halogen (chlorine-free) flux and make sure, without cleaning, there is no residue such as chlorine. This is one of the ways to eliminate the effects of flux. In such a case, check the reliability.

(4) Vibration and Shock

This module is plastic sealed and has its wire fixed by resin. This structure is relatively resistant to vibration and shock. In actual equipment, there are sometime cases in which vibration, shock, or stress is applied to soldered parts or connected parts, resulting in line cut. A care must be taken in the design of equipment which will be subject to high levels of vibration. for applications which are subject to large amounts of vibration.

(5) Support Pin

The optical transmitting module TOTX179L has support pins in order to fix itself to the PCB temporary. Please make the hole for these pins in the PCB under the condition described in board layout hole pattern.

(6) Panel Attachment

The optical transmitting module TOTX179L has hole for panel attachment. Please be sure to attach it to panel with self-tapping screw.

(7) Solvent

When using solvent for flux removal, do not use a high acid or high alkali solvent. Be careful not to pour solvent in to the optical connector ports. If solvent is inadvertently poured in to them, clean it off using cotton tips.

(8) Supply voltage

Use the supply voltage within the recommended operating condition ($V_{cc}=5\pm 0.25V$). Make sure that supply voltage does not exceed the maximum rating value of 7V, even for an instant.

(9) Input voltage

If a voltage exceeding the maximum rating value ($V_{cc}+0.5V$) is applied to the transmitter's input, the internal IC may suffer damage. If there is a possibility that excessive voltage due to surges may be added to the input terminal, insert a protective circuit.

(10) Soldering condition

Solder at 260°C or less for no more than ten seconds.

(11) The hole for optical module

Please make a hole for inserting optical connector the slash part of the following figure in case.

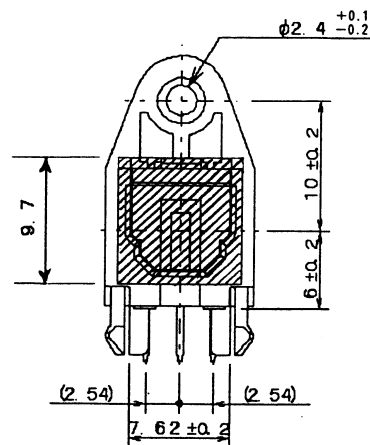

(12) Case(receptacle) material

The case is made of polycarbonate. Polycarbonate is usually stable with acid, alcohol, and aliphatic hydrocarbons however, with petrochemicals (such as benzene, toluene, and acetone), alkali, aromatic hydrocarbons, or chloric hydrocarbons, polycarbonate becomes cracked, swollen, or melted. Please take care when choosing a packaging material by referencing the table below.
(Chemicals to avoid with polycarbonate)

	PHENOMENON	CHEMICALS
A	Little deterioration But staining	• nitric acid(low concentration), hydrogen peroxide, chlorine
B	Cracked, crazed, or Swollen	• acetic acid(70% or more) • gasoline • methyl ethyl ketone, ethyl acetate, butyl acetate • ethyl methacrylate, ethyl ether, MEK • acetone, m-amino alcohol, carbon tetrachloride • carbon disulfide, trichloroethylene, cresol • thinners, oil of turpentine • triethanolamine
C	Melted { } : used as solvent	• concentrated sulfuric acid • benzene • styrene, acrylonitrile, vinyl acetate • ethylenediamine, diethylenediamine • {chloroform, methyl chloride, tetrachloromethane, dioxane} {1,2-dichloroethane}
D	Decomposed	• ammonia water • other alkali

(13) Precautions when disposing of devices and packing materials

When discarding devices and packing materials, follow the procedures stipulated by local regulations in order to protect the environment against contamination.

Compound semiconductors such as GaAs are used LED materials in this module. When devices are disposed of, worker safety and protection of the environment must be taken into account.

(14) Precautions during use

Toshiba is continually working to improve the quality and the reliability of their products. Nevertheless, semiconductor devices in general can malfunction or fail due to their inherent electrical sensitivity and their vulnerability to physical stress. It is the responsibility of the buyer, when utilizing Toshiba products, to observe standards of safety, and to avoid situations in which a malfunction or failure of a Toshiba product could cause loss of human life, bodily injury or damage to property.

When developing equipment, please ensure that Toshiba products are used within specified operating ranges as set forth in the most recent product specifications. Also, please keep in mind the precautions and conditions set forth in the Toshiba Semiconductor Reliability Handbook.

- TOSHIBA is continually working to improve the quality and reliability of its products. Nevertheless, semiconductor devices in general can malfunction or fail due to their inherent electrical sensitivity and vulnerability to physical stress. It is the responsibility of the buyer, when utilizing TOSHIBA products, to comply with the standards of safety in making a safe design for the entire system, and to avoid situations in which a malfunction or failure of such TOSHIBA products could cause loss of human life, bodily injury or damage to property. In developing your designs, please ensure that TOSHIBA products are used within specified operating ranges as set forth in the most recent TOSHIBA products specifications. Also, please keep in mind the precautions and conditions set forth in the "Handling Guide for Semiconductor Devices," or "TOSHIBA Semiconductor Reliability Handbook" etc..
- The TOSHIBA products listed in this document are intended for usage in general electronics applications (computer, personal equipment, office equipment, measuring equipment, industrial robotics, domestic appliances, etc.). These TOSHIBA products are neither intended nor warranted for usage in equipment that requires extraordinarily high quality and/or reliability or a malfunction or failure of which may cause loss of human life or bodily injury ("Unintended usage"). Unintended Usage include atomic energy control instruments, airplane or spaceship instruments, transportation instruments, traffic signal instruments, combustion control instruments, medical instruments, all types of safety devices, etc.. Unintended Usage of TOSHIBA products listed in this document shall be made at the customer's own risk.
- Gallium arsenide (GaAs) is a substance used in the products described in this document. GaAs dust and fumes are toxic. Do not break, cut or pulverize the product, or use chemicals to dissolve them. When disposing of the products, follow the appropriate regulations. Do not dispose of the products with other Industrial waste or with domestic garbage.
- The information contained herein is presented only as a guide for the applications of our products. No responsibility is assumed by TOSHIBA CORPORATION for any infringements of intellectual property or other rights of the third parties which may result from its use. No license is granted by implication or otherwise under any intellectual property or other rights of TOSHIBA CORPORATION or others.
- The information contained herein is subject to change without notice.