

# HFE4020-313/XXX

## Fiber Optic LED

---

### FEATURES

- Power out designed for drive currents between 10 and 100 mA
- Wave solderable
- Optimized for linear optical output with drive currents between 10 mA and 100 mA
- High speed: 85 MHz
- Mounting options
  - SMA single hole
  - ST single hole
  - SMA PCB
  - ST PCB
  - SMA 4 hole

### DESCRIPTION

The HFE4020-313/XXX is a high radiance GaAlAs 850 nanometer LED optimized for coupling into small fiber core diameters at a forward current of 10 to 100 mA. The patented "Caprock"™ LED chip combines high power coupling with wide bandwidth. The peak wavelength is matched for use with Honeywell silicon fiber optic detectors and receivers. When the HFE4020-313/XXX is used at elevated temperatures, thermal resistance must be taken into consideration.

### APPLICATION

The HFE4020-313/XXX is a high radiance LED packaged in a fiber optic connector that aligns the optical axis of the base component to the axis of the optical fiber. Data rates can vary from DC to above 85 MHz depending upon component application. The LED converts electrical current into optical power that can be used in fiber optic communications. As the current varies (typically from 10 to 100 mA), the light intensity increases proportionally.

The HFE4020-313/XXX LED is designed to give high fiber coupled power (high radiance into a standard fiber optic cable). In order to enhance the light being sent into a fiber optic cable, a 0.30 mm diameter glass microlens is placed over the "Caprock"™ junction. The microlens collimates the light, increasing the intensity directed toward a fiber optic cable. This creates a "SWEET SPOT" of power, allowing greater power to be launched into standard fiber optic cables.

Honeywell reserves the right to make changes in order to improve design and supply the best products possible.

**Honeywell**

217

# HFE4020-313/XXX

## Fiber Optic LED

### ELECTRO-OPTICAL CHARACTERISTICS (-40°C < T<sub>C</sub> < 100°C unless otherwise stated)

PARAMETER	SYMBOL	MIN	TYP	MAX	UNITS	TEST CONDITIONS
Fiber Coupled Power	P <sub>OC</sub>	30 -15.2	60 -12.2		μW dBm	I <sub>F</sub> = 50 mA, 100/140 micron, 0.29 NA fiber, T = 25°C (1)
Forward Voltage	V <sub>F</sub>		1.70	2.00	V	I <sub>F</sub> = 100 mA
Reverse Voltage	B <sub>VR</sub>	1.0	5.0		V	I <sub>R</sub> = 10 μA
Peak Wavelength	λ <sub>P</sub>		850		nm	I <sub>F</sub> = 100 mA DC
Spectral Bandwidth	Δλ		50		nm	I <sub>F</sub> = 100 mA DC
Response Time					ns	1 V Prebias, 100 mA peak
T = 25°C, 10-90%	t <sub>R</sub>		6	8		
T = 25°C, 90-10%	t <sub>F</sub>		8	10		
-40 < T < +100°C, 10-90%	t <sub>R</sub>		6	9		
-40 < T < +100°C, 90-10%	t <sub>F</sub>		8	11		
Analog Bandwidth	BWE		85		MHz	I <sub>F</sub> = 100 mA DC, small signal sinusoidal modulation
P <sub>O</sub> Temperature Coefficient	ΔP <sub>O</sub> /ΔT		-0.019		dB/°C	I <sub>F</sub> = 100 mA
Series Resistance	r <sub>S</sub>		4.0		Ω	DC
Capacitance	C		70		pF	V <sub>R</sub> = 0 V, f = 1 MHz
Thermal Resistance			250		°C/W	Heat sinked

#### Notes

1. HFE4020-313/XXX is tested using a 100/140 micron fiber cable. Actual coupled power values may vary due to mechanical alignment procedures and/or receptacle and fiber tolerances.

#### ABSOLUTE MAXIMUM RATINGS

(25°C Free-Air Temperature unless otherwise noted)

Storage temperature	-40 to +100°C
Case operating temperature	-40 to +100°C
Lead solder temperature	260°C, 10 s
Continuous forward current (heat sinked)	100 mA
Reverse voltage	1 V @ 10 μA

Stresses greater than those listed under "Absolute Maximum Ratings" may cause permanent damage to the device. This is a stress rating only and functional operation of the device at these or any other conditions above those indicated in the operational section of this specification is not implied. Exposure to absolute maximum rating conditions for extended periods of time may affect reliability.

#### FIBER INTERFACE

Honeywell LEDs are designed to interface with multimode fiber with sizes ranging from 50/125 to 200/230 microns. Honeywell performs final tests using 50/125 micron core fiber. All multimode fiber optic cables between 50/125 and 200/230 should operate with similar excellent performance. See table for typical powers.

#### TYPICAL COUPLED POWER (μW/dBm) @ I<sub>F</sub>=50 mA

Dia.	Index	N.A.	-313
50/125	Graded	0.20	10/-19.9
62.5/125	Graded	0.28	19/-17.1
100/140	Graded	0.29	60/-12.2

# HFE4020-313/XXX

## Fiber Optic LED

### ORDER GUIDE

Description	Catalog Listing
Standard screening, typical power out 60 $\mu$ W	HFE4020-313/XXX

### MOUNTING OPTIONS

substitute XXX with one of the following 3 letter combinations

SMA single hole	- AAA
ST single hole	- BAA
SMA PCB	- ABA
ST PCB	- BBA
SMA 4 hole	- ADA

Dimensions on page 203

### WARNING

Under certain application conditions, the infrared optical output of this device may exceed Class 1 eye safety limits, as defined by IEC 825-1 (1993-11). Do not use magnification (such as a microscope or other focusing equipment) when viewing the device's output.

### CAUTION

The inherent design of this component causes it to be sensitive to electrostatic discharge (ESD). To prevent ESD-induced damage and/or degradation to equipment, take normal ESD precautions when handling this product.



Fig. 1 Typical Optical Power Output vs Forward Current

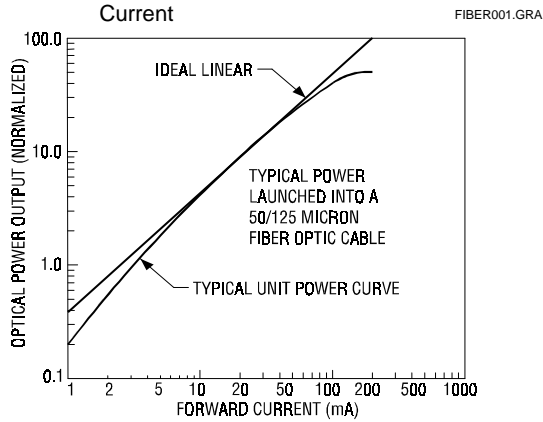

Fig. 2 Typical Spectral Output vs Wavelength

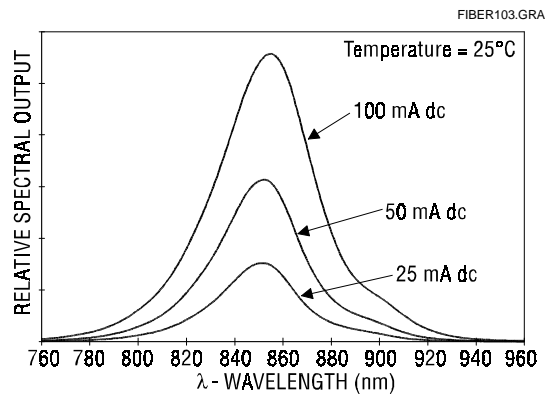
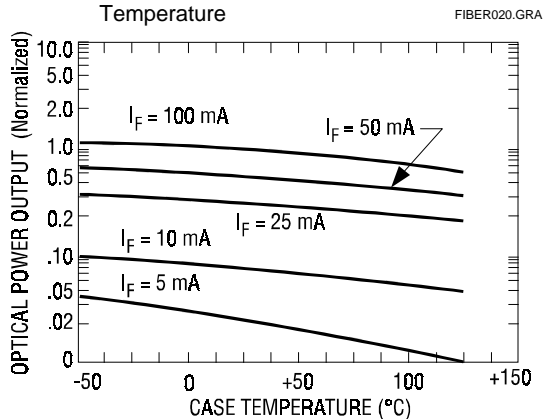

Fig. 3 Typical Optical Power Output vs Case Temperature



All Performance Curves Show Typical Values

Honeywell reserves the right to make changes in order to improve design and supply the best products possible.

# Honeywell

# HFE4020-313/XXX

Fiber Optic LED

---

# European Connectorized LEDs/Transmitters

Honeywell LED/transmitter components are available in the following connector styles. Each style has a three-digit reference used in the order guides.

## SMA SINGLE HOLE MOUNTING (REF.: AAA)

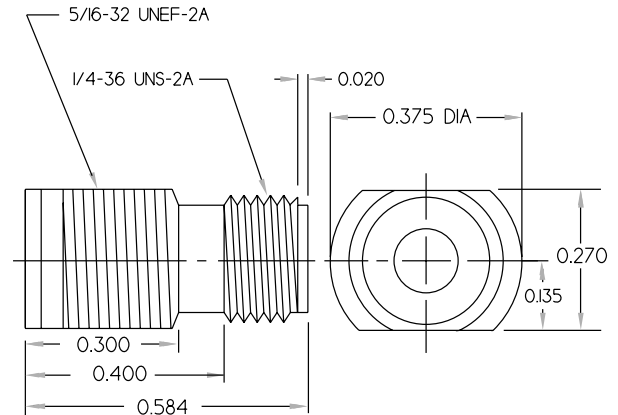

## ST SINGLE HOLE MOUNTING (REF.: BAA)

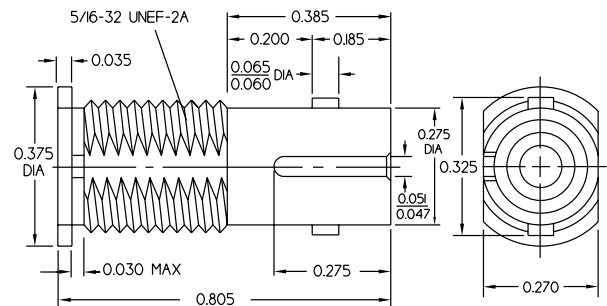

## SMA PCB MOUNTING (REF.: ABA)

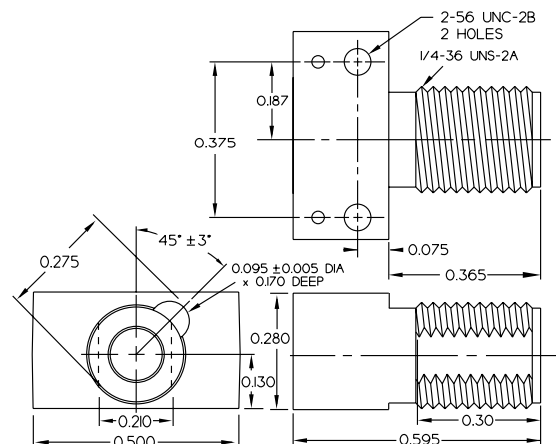
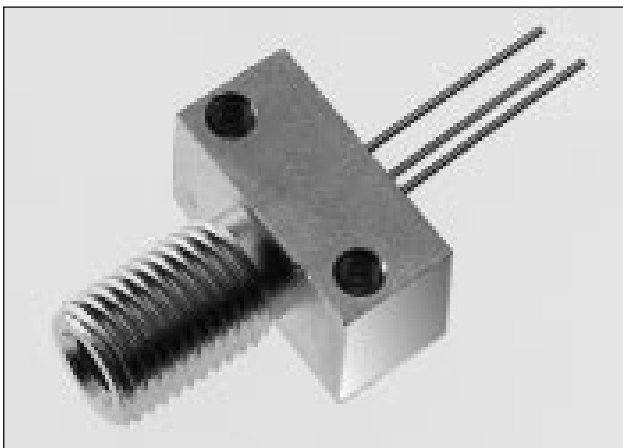

Honeywell Optoelectronics reserves the right to make changes at any time in order to improve design and supply the best products possible.

**Honeywell**

# European Connectorized LEDs/Transmitters

## ST PCB MOUNTING (REF.: BBA)

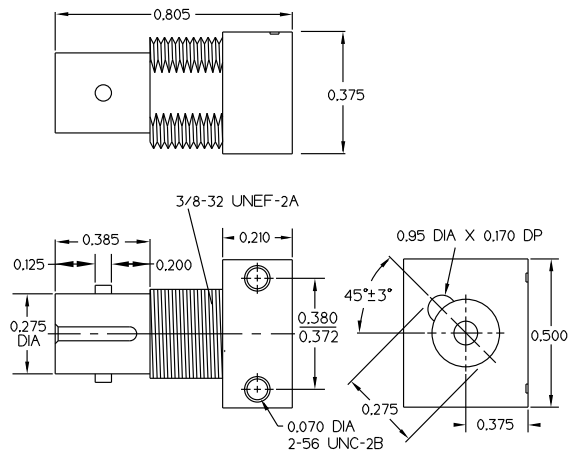

## SMA 4 HOLE MOUNTING (REF.: ADA)

