



V23818-M305-B57

Small Form Factor Pluggable SFP

Multimode 850 nm 2.125 and 1.0625 GBd

Fibre Channel Transceiver with LC™ Connector

Preliminary

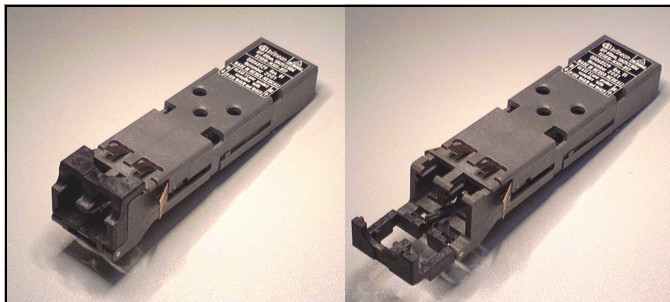
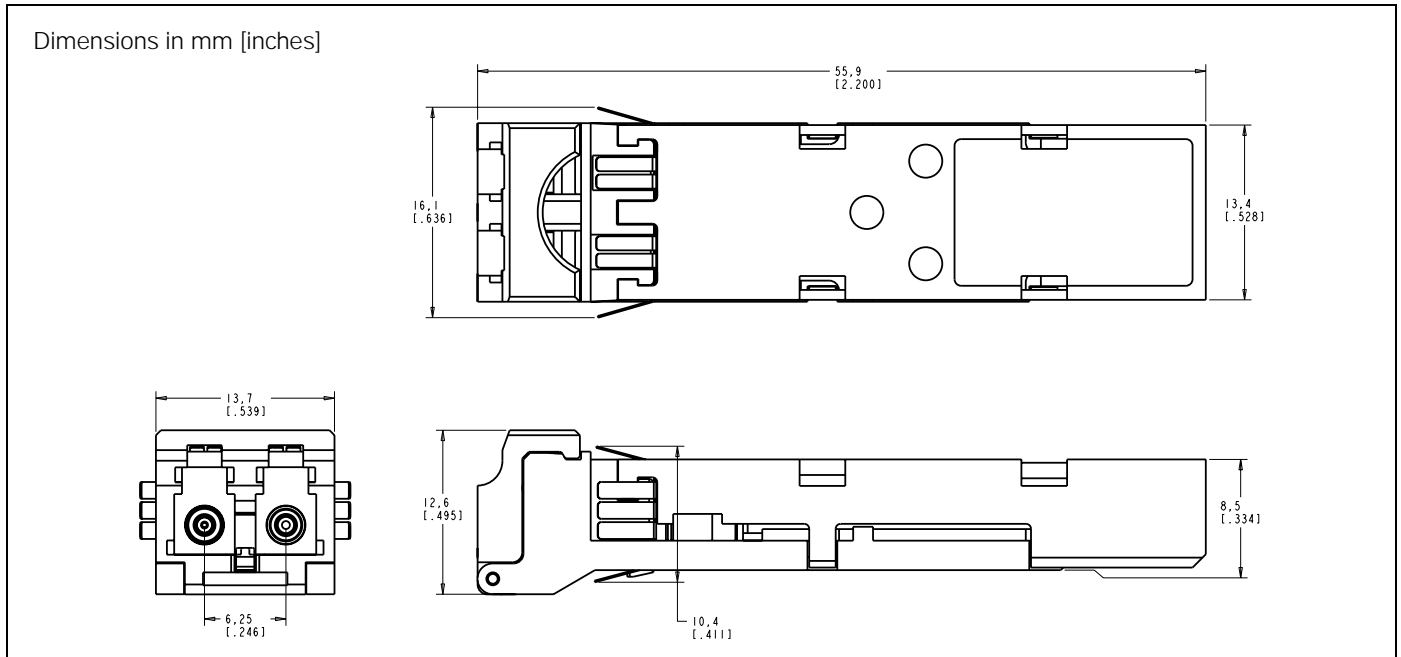

- Small size for high channel density
- UL-94 V-0 certified
- ESD Class 1 per MIL-STD 883D Method 3015.7
- Compliant with FCC (Class B) and EN 55022
- For distances of up to 700 m (50 µm fiber)
- Class 1 FDA and IEC laser safety compliant
- AC/AC Coupling according to SFP MSA
- Recommendation: Infineon Cage one-piece design V23818-S5-N1 for press fit and/or solderable
- Operating case temperature: -10°C to 85°C

Note

1. The SFP MSA can be found at www.infineon.com/fiberoptics next to the transceiver datasheets.

Absolute Maximum Ratings

Exceeding any one of these values may destroy the device immediately.

Package Power Dissipation.....	1.5 W
Data Input Levels (PECL).....	$V_{CC} + 0.5$ V
Differential Data Input Voltage.....	2.4 V
Storage Ambient Temperature	-40°C to 85°C
V_{CC} max.....	5.5 V
ECL Output current data	50 mA

FEATURES

- Small Form Factor Pluggable transceiver
- Fully SFP MSA compliant⁽¹⁾
- Advanced release mechanism
 - easy access, even in belly to belly applications
 - grip for easy access - no tool is needed
 - color coded release mechanism
 - MM: black color coding
 - SM: blue color coding
- Excellent EMI performance
- RJ-45 style LC™ connector system
- Single power supply (3.3 V)
- Extremely low power consumption of 415 mW typical
- Data rate autonegotiation between 1.0625 and 2.125 GBd

DESCRIPTION

The Infineon Fibre Channel multimode transceiver – part of Infineon Small Form Factor transceiver family – is based on the Physical Medium Depend (PMD) sublayer and baseband medium, type (short wavelength), Fibre Channel FC-PI 200-M5-SN-I, 200-M6-SN-I FC-PI 100-M5-SN-I, 100-M6-SN-I FC-PH2 100-M5-SN-I, FC-PH2 100-M6-SN-I.

The appropriate fiber optic cable is 62.5 μm or 50 μm multimode fiber with LC™ connector.

Operating range over each optical fiber type at 2.125 GBd

Fiber type	Min.	Typ. (meters)	Max.
62.5 micron MMF	0.5	2 to 150	300
50.0 micron MMF	0.5	2 to 300	500

Operating range over each optical fiber type at 1.0625 GBd

Fiber type	Min.	Typ. (meters)	Max.
62.5 micron MMF	0.5	2 to 300	400
50.0 micron MMF	0.5	2 to 550	700

The Infineon Fibre Channel multimode transceiver is a single unit comprised of a transmitter, a receiver, and an LC™ receptacle.

This transceiver supports the LC™ connectorization concept. It is compatible with RJ-45 style backpanels for high end Data Com and Telecom applications while providing the advantages of fiber optic technology.

The module is designed for low cost SAN, LAN, WAN, Fibre Channel applications. It can be used as the network end device interface in mainframes, workstations, servers, and storage devices, and in a broad range of network devices such as bridges, routers, hubs, and local and wide area switches.

This transceiver operates at 1.0625 GBd / 2.125 GBd from a single power supply (+3.3 V). The full differential data inputs and outputs are PECL and LVPECL compatible.

Functional Description of SFP Transceiver

This transceiver is designed to transmit serial data via multimode cable.

Functional Diagram

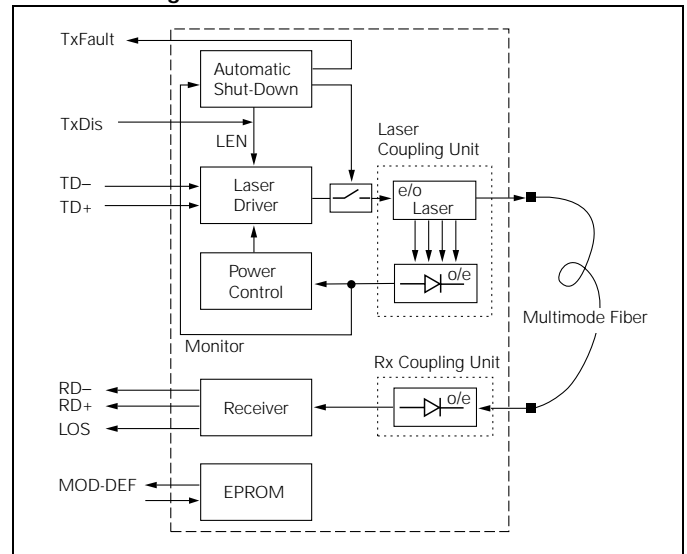

The receiver component converts the optical serial data into PECL compatible electrical data (RD+ and RD-). The LOS of Signal (LOS, active low) shows whether an optical signal is present.

The transmitter converts PECL compatible electrical serial data (TD+ and TD-) into optical serial data. Data lines are differentially 100 Ω terminated.

The transmitter contains a laser driver circuit that drives the modulation and bias current of the laser diode. The currents are controlled by a power control circuit to guarantee constant output power of the laser over temperature and aging. The power control uses the output of the monitor PIN diode (mechanically built into the laser coupling unit) as a controlling signal, to prevent the laser power from exceeding the operating limits.

Single fault condition is ensured by means of an integrated automatic shutdown circuit that disables the laser when it detects laser fault to guarantee the laser Eye Safety.

The transceiver contains a supervisory circuit to control the power supply. This circuit makes an internal reset signal whenever the supply voltage drops below the reset threshold. It keeps the reset signal active for at least 140 milliseconds after the voltage has risen above the reset threshold. During this time the laser is inactive.

A low signal on TxDis enables transmitter. If TxDis is high or not connected the transmitter is disabled.

The information which kind of SFP module has been plugged into an SFP port can be read through the MOD-DEF interface. The information is stored in an I²C-Eprom inside the SFP Transceiver.

TECHNICAL DATA

The electro-optical characteristics described in the following tables are valid only for use under the recommended operating conditions.

Recommended Operating Conditions

Parameter	Symbol	Min.	Typ.	Max.	Units
Case Temperature	T_C	-10		85	°C
Power Supply Voltage	$V_{CC-V_{EE}}$	3.1	3.3	3.5	V
Transmitter					
Data Input Differential Voltage	V_{DIFF}	250		2400	mV
Receiver					
Input Center Wavelength	λ_C	770		860	nm

Transmitter Electro-Optical Characteristics

Transmitter	Symbol	Min.	Typ.	Max.	Units
Launched Power (Average) ⁽¹⁾	P_O	-9.5	-6	-4	dBm
Optical Modulation Amplitude ⁽³⁾	2.125 Gbit/s	OMA	196	450	μ W
	1.0625 Gbit/s		156	450	
Center Wavelength	λ_C	830	850	860	nm
Spectral Width (RMS)	σ_I			0.85	
Relative Intensity Noise	RIN			-117	dB/Hz
Extinction Ratio (Dynamic)	ER	9	13		dB
Total Tx Jitter	TJ		40	80	ps
Reset Threshold ⁽²⁾	V_{TH}	2.5	2.75	2.99	V
Reset Time Out ⁽²⁾	t_{RES}	140	240	560	ms
Rise Time, 20%–80%	t_R			150	ps
Supply Current			45	65	mA

Notes

1. Into multimode fiber, 62.5 μ m or 50 μ m diameter.
2. Laser power is shut down if power supply is below V_{TH} and switched on if power supply is above V_{TH} after t_{RES} .
3. Fibre Channel PI Standard.

Receiver Electro-Optical Characteristics

Receiver	Symbol	Min.	Typ.	Max.	Units	
Sensitivity (Average Power) ⁽¹⁾	2.125 Gbit/s	P_{IN}		-18.5	-16	dBm
	1.0625 Gbit/s			-19.5	-17	
Saturation (Average Power)	P_{SAT}	0				
Min. Optical Modulation Amplitude ⁽⁷⁾	2.125 Gbit/s	OMA		24	49	μ W
	1.0625 Gbit/s			19	31	
Stressed Receiver Sensitivity 50 μ m Fiber ⁽⁶⁾	2.125 Gbit/s	SPIN 50 μ m		29	96	
	1.0625 Gbit/s			24	55	
Stressed Receiver Sensitivity 62.5 μ m Fiber ⁽⁶⁾	2.125 Gbit/s	SPIN 62.5 μ m		34	109	
	1.0625 Gbit/s			32	67	
LOS of Signal Assert Level ⁽²⁾	P_{LOSA}			-23	-18	dBm
LOS of Signal Deassert Level ⁽³⁾	P_{LOSD}	-30	-25			dB
LOS of Signal Hysteresis	$P_{LOSA} - P_{LOSD}$	0.5	2			
LOS of Signal Assert Time	t_{ASS}				100	μ s
LOS of Signal Deassert Time	t_{DAS}				350	
Receiver 3 dB cut off Frequency ⁽⁷⁾					2.5	GHz
Receiver 10 dB cut off Frequency ⁽⁷⁾					6	
Data Output Differential Voltage ⁽⁴⁾	V_{DIFF}	0.5	0.7	1.23		V
Return Loss of Receiver	A_{RL}	12				dB
Supply current ⁽⁵⁾			80	90		mA

Notes

1. Average optical power at which the BER is 1×10^{-12} . Measured with a 2⁷-1 NRZ PRBS and ER=9 dB.
2. An increase in optical power above the specified level will cause the LOS of Signal output to switch from a High state to a Low state.
3. A decrease in optical power below the specified level will cause the LOS of Signal to change from a Low state to a High state.
4. AC/AC for data. Load 50 Ω to GND or 100 Ω differential. For dynamic measurement a tolerance of 50 mV should be added.
5. Supply current excluding Rx output load.
6. Measured at the given Stressed Receiver Eye Closure Penalty and DCD component given in Fibre Channel PI Standard (2.03/2.18 dB & 40/80 ps).
7. Fibre Channel PI Standard.

Timing of Control and Status I/O

Parameter	Symbol	Min.	Max.	Units	Condition
Tx Disable Assert Time	t_off		10	µs	Time from rising edge of Tx Disable to when the optical output falls below 10% of nominal.
Tx Disable Negate Time	t_on		1	ms	Time from falling edge of Tx Disable to when the modulated optical output rises above 90% of nominal.
Time to initialize, including reset of Tx_Fault	t_init		300		From power on or negation of Tx Fault using Tx Disable.
Tx Fault Assert Time	t_fault		100	µs	Time from fault to Tx fault on.
Tx Disable to reset	t_reset	10			Time Tx Disable must be held high to reset Tx_fault.
LOS Assert Time	t_loss_on		100		Time from LOS state to Rx LOS assert.
LOS Deassert Time	t_loss_off		100		Time from non-LOS state to Rx LOS deassert.
Serial ID Clock Rate	f_serial_clock		100	kHz	

Pin Description

Pin Name		Level/Logic	Pin#	Description
V _{EE} T	Transmitter Ground	N/A	1	
Tx Fault	Transmitter Fault Indication	TTL	2	Logical 1 indicates that Laser Shut-Down is active.
Tx Disable	Transmitter Disable	TTL	3	A low signal switches the laser on. A high signal switches the laser off. If not connected the Tx is disabled.
MOD-DEF2	Module Definition 2	TTL	4	Mod-Def 2 is the data line of two wire serial interface for serial ID.
MOD-DEF1	Module Definition 1	TTL	5	Mod-Def 1 is the clock line of two wire serial interface for serial ID.
MOD-DEF0	Module Definition 0	N/A	6	Mod-Def 0 is grounded by the module to indicate that the module is present.
Rate Select	Not connected	N/A	7	
LOS	Loss of Signal	TTL	8	Normal Operation: Logic "0" Output, represents that light is present at receiver input. Fault Condition: Logic "1" Output.
V _{EE} R	Receiver Ground	N/A	9	
V _{EE} R	Receiver Ground	N/A	10	
V _{EE} R	Receiver Ground	N/A	11	
RD-	Inv. Received Data Out	LV PECL	12	AC Coupled inside the Transceiver.
RD+	Received Data Out	LV PECL	13	
V _{EE} R	Receiver Ground	N/A	14	
V _{CC} R	Receiver Power	N/A	15	
V _{CC} T	Transmitter Power	N/A	16	
V _{EE} T	Transmitter Ground	N/A	17	
TD+	Transmit Data In	LV PECL	18	AC Coupled inside the Transceiver and 100 Ω differential terminated.
TD-	Inv. Transmit Data In	LV PECL	19	
V _{EE} T	Transmitter Ground	N/A	20	

Regulatory Compliance

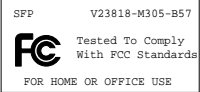
Feature	Standard	Comments
	Compliant with 89/336/EEC	EN 55022 EN 55024
ESD: Electrostatic Discharge to the Electrical Pins	EIA/JESD22-A114-A (MIL-STD 883D Method 3015.7)	Class 1 (> 1000 V)
Immunity: Against Electrostatic Discharge (ESD) to the Duplex LC Receptacle	EN 61000-4-2 IEC 61000-4-2	Discharges ranging from ± 2 kV to ± 15 kV on the receptacle cause no damage to transceiver (under recommended conditions).
Immunity: Against Radio Frequency Electro-magnetic Field	EN 61000-4-3 IEC 61000-4-3	With a field strength of 3 V/m rms, noise frequency ranges from 10 MHz to 2 GHz. No effect on transceiver performance between the specification limits.
Emission: Electromagnetic Interference (EMI)	FCC 47 CFR Part 15, Class B EN 55022 Class B CISPR 22	Noise frequency range: 30 MHz to 18 GHz
		This device complies with part 15 of the FCC Rules. Operation is subject to the following two conditions: 1. This device may not cause harmful interference. 2. This device must accept any interference received, including interference that may cause undesired operation.

EYE SAFETY

This laser based multimode transceiver is a Class 1 product. It complies with IEC 60825-1 and FDA 21 CFR 1040.10 and 1040.11.

To meet laser safety requirements the transceiver shall be operated within the Absolute Maximum Ratings.

Caution

All adjustments have been made at the factory prior to shipment of the devices. No maintenance or alteration to the device is required.

Tampering with or modifying the performance of the device will result in voided product warranty.

Note

Failure to adhere to the above restrictions could result in a modification that is considered an act of "manufacturing", and will require, under law, recertification of the modified product with the U.S. Food and Drug Administration (ref. 21 CFR 1040.10 (j)).

Laser Data

Wavelength	850 nm
Total output power (as defined by IEC: 7 mm aperture at 1.4 cm distance)	<675 μ W
Total output power (as defined by FDA: 7 mm aperture at 20 cm distance)	<70 μ W
Beam divergence	12°

Required Labels

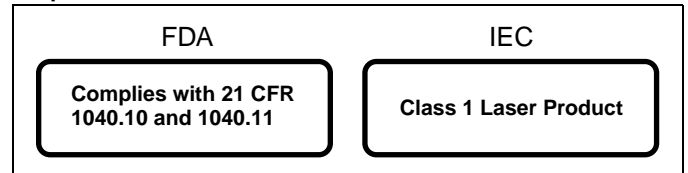

Laser Emission

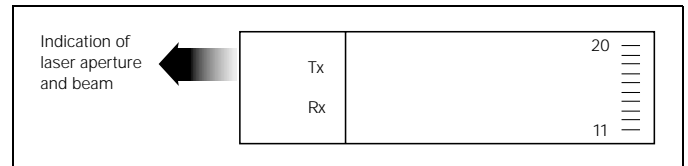

SFP Transceiver Electrical Pad Layout

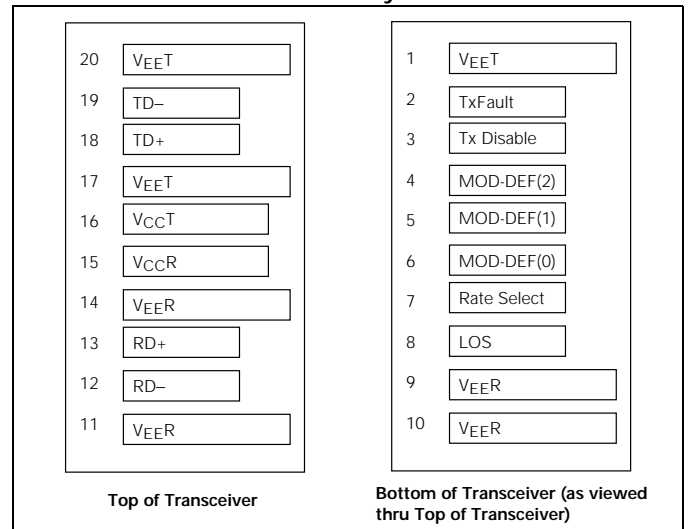

APPLICATION NOTES

EMI-Recommendation

To avoid electromagnetic radiation exceeding the required limits please take note of the following recommendations.

When Gigabit switching components are found on a PCB (multiplexers, clock recoveries etc.) any opening of the chassis may produce radiation also at chassis slots other than that of the device itself. Thus every mechanical opening or aperture should be as small as possible.

On the board itself every data connection should be an impedance matched line (e.g. strip line, coplanar strip line). Data, Datanot should be routed symmetrically, vias should be avoided. A terminating resistor of 100 Ω should be placed at the end of each matched line. An alternative termination can be provided with a 50 Ω resistor at each (D, Dn). In DC coupled systems a thevenin equivalent 50 Ω resistance can be achieved as follows: For 3.3 V: 125 Ω to V_{CC} and 82 Ω to V_{EE} , for 5 V: 82 Ω to V_{CC} and 125 Ω to V_{EE} at Data and Datanot. Please consider whether there is an internal termination inside an IC or a transceiver.

In certain cases signal GND is the most harmful source of radiation. Connecting chassis GND and signal GND at the plate/bezel/ chassis rear e.g. by means of a fiber optic transceiver may result in a large amount of radiation. Even a capacitive coupling between signal GND and chassis may be harmful if it is too close to an opening or an aperture.

If a separation of signal GND and chassis GND is not possible, it is strongly recommended to provide a proper contact between signal GND and chassis GND at every location where possible. This concept is designed to avoid hotspots. Hotspots are places of highest radiation which could be generated if only a few connections between signal and chassis GND exist. Compensation currents would concentrate at these connections, causing radiation.

By use of Gigabit switching components in a design, the return path of the RF current must also be considered. Thus a split GND plane of Tx and Rx portion may result in severe EMI problems.

The cutout should be sized so that all contact springs make good contact with the face plate.

For the SFP transceiver a connection of the SFP cage pins to chassis GND is recommended. If no separate chassis GND is available on the users PCB the pins should be connected to signal GND. In this case take care of the notes above.

Please consider that the PCB may behave like a waveguide. With an ϵ_r of 4, the wavelength of the harmonics inside the PCB will be half of that in free space. In this scenario even the smallest PCBs may have unexpected resonances.

The SFP transceiver can be assembled onto the host board together with all cages and host board connectors complying with the SFP multi source agreement.

Infineon Proposes

Cage:

Infineon Technologies
Part Number: V23818-S5-N1

Host board connector:

Tyco Electronics
Part Number: 1367073-1

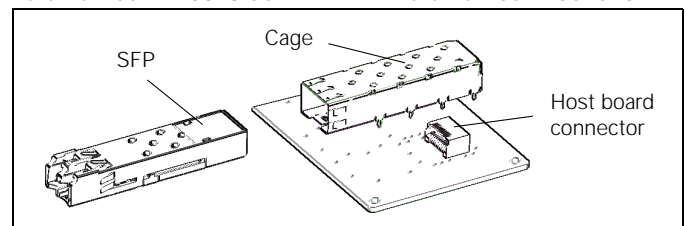

EEPROM Serial ID Memory Contents

The data can be read using the 2-wire serial CMOS E2PROM protocol of the Atmel AT24C01A or equivalent.

Address	Hex	ASCII	Address	Hex	ASCII	Address	Hex	ASCII	Address	Hex	ASCII
0	03		32	20		64	00		96	20	
1	04		33	20		65	1A		97	20	
2	07		34	20		66	69		98	20	
3	00		35	20		67	2D		99	20	
4	00		36	00		68 ⁽²⁾			100	20	
5	00		37	00		69 ⁽²⁾			101	20	
6	01		38	03		70 ⁽²⁾			102	20	
7	40		39	19		71 ⁽²⁾			103	20	
8	40		40	56	V	72 ⁽²⁾			104	20	
9	0C		41	32	2	73 ⁽²⁾			105	20	
10	05		42	33	3	74 ⁽²⁾			106	20	
11	01		43	38	8	75 ⁽²⁾			107	20	
12	15		44	31	1	76 ⁽²⁾			108	20	
13	00		45	38	8	77 ⁽²⁾			109	20	
14	00		46	2D	-	78 ⁽²⁾			110	20	
15	00		47	4D	M	79 ⁽²⁾			111	20	
16	1E		48	33	3	80 ⁽²⁾			112	20	
17	0F		49	30	0	81 ⁽²⁾			113	20	
18	00		50	35	5	82 ⁽²⁾			114	20	
19	00		51	2D	-	83 ⁽²⁾			115	20	
20	49	l	52	42	B	84 ⁽³⁾			116	20	
21	6E	n	53	35	5	85 ⁽³⁾			117	20	
22	66	f	54	37	7	86 ⁽³⁾			118	20	
23	69	i	55	20		87 ⁽³⁾			119	20	
24	6E	n	56	00		88 ⁽³⁾			120	20	
25	65	e	57	00		89 ⁽³⁾			121	20	
26	6F	o	58	00		90 ⁽³⁾			122	20	
27	6E	n	59	00		91 ⁽³⁾			123	20	
28	20		60	00		92	00		124	20	
29	41	A	61	00		93	00		125	20	
30	47	G	62	00		94	00		126	20	
31	20		63 ⁽¹⁾	E6		95 ⁽⁴⁾			127	20	

Notes

1. Address 63 is check sum of bytes 0–63
2. Address 61–83 Vendor Serial Number
3. Date code
4. Address 95 is check sum of bytes 64–94

Multimode 850 nm Fibre Channel SFP Transceiver, AC/AC TTL
Recommended Host Board Supply Filtering Network

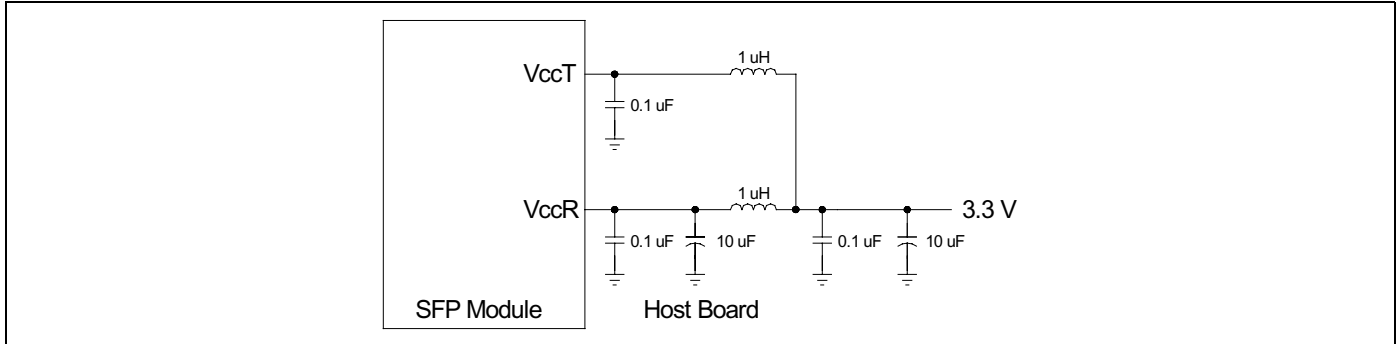

Example SFP Host Board Schematic

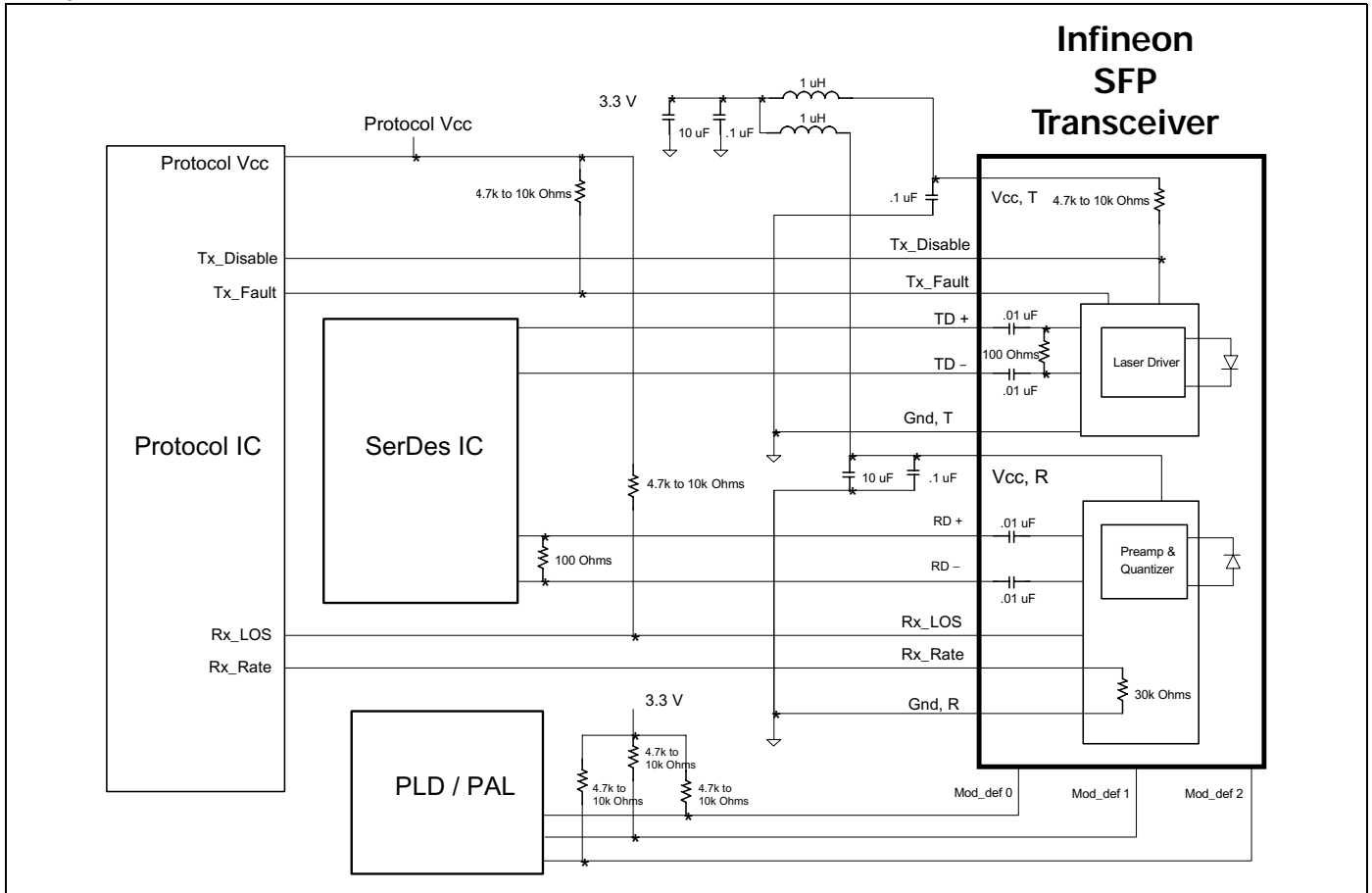

Published by Infineon Technologies AG

© Infineon Technologies AG 2002
 All Rights Reserved

Attention please!

The information herein is given to describe certain components and shall not be considered as warranted characteristics.
 Terms of delivery and rights to technical change reserved.
 We hereby disclaim any and all warranties, including but not limited to warranties of non-infringement, regarding circuits, descriptions and charts stated herein.
 Infineon Technologies is an approved CECC manufacturer.

Information

For further information on technology, delivery terms and conditions and prices please contact the Infineon Technologies offices or our Infineon Technologies Representatives worldwide - see our webpage at www.infineon.com/fiberoptics

Warnings

Due to technical requirements components may contain dangerous substances. For information on the types in question please contact your Infineon Technologies offices.
 Infineon Technologies Components may only be used in life-support devices or systems with the express written approval of Infineon Technologies, if a failure of such components can reasonably be expected to cause the failure of that life-support device or system, or to affect the safety or effectiveness of that device or system. Life support devices or systems are intended to be implanted in the human body, or to support and/or maintain and sustain and/or protect human life. If they fail, it is reasonable to assume that the health of the user or other persons may be endangered.