

DESCRIPTION

The Infineon multi mode transceiver is based on the Physical Medium Depend (PMD) sublayer and baseband medium, type 1000BASE-SX (Long Wavelength Laser) (IEEE 802.3z) and complies with the Fibre Channel Physical and Signaling Interface (FC-PH), ANSI XSI TT Fibre Channel Physical Standard Class 100-M5-SLI, latest Revision.

The appropriate fiber optic cable is 62.5 μm or 50 μm multi-mode fiber with Duplex SC connector.

The Infineon multi mode transceiver is a single unit comprised of a transmitter, a receiver, and an SC receptacle. This design frees the customer from many alignment and PC board layout concerns.

The module is designed for low cost LAN, WAN, Gigabit Ethernet, and Fibre Channel applications. It can be used as the network end device interface in mainframes, workstations, servers, and storage devices, and in a broad range of network devices such as bridges, routers, intelligent hubs, and local and wide area switches.

This transceiver operates at 1.0625 Gbit/s and 1.3 Gbit/s from a single power supply (+5 Volt or 3.3 Volt). The full differential data inputs and outputs are PECL compatible.

Operating range each optical fiber type at 1.0625 GBd

Fiber type	Minimum range (meters)	Typ.
62.5 micron MFF	2 to 260	400
50.0 micron MFF	2 to 550	700

Functional Description

This transceiver is designed to transmit serial data via multi-mode cable.

Functional Diagram

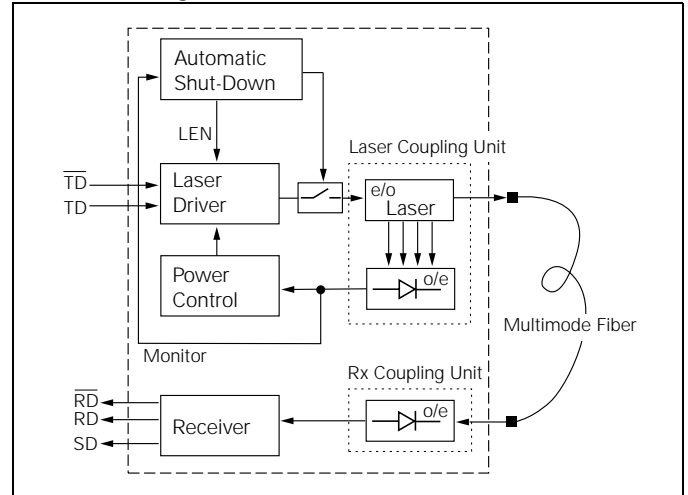

The receiver component converts the optical serial data into PECL compatible electrical data (RD and RDnot). The Signal Detect (SD, active high) shows whether an optical signal is present.

The transmitter converts electrical PECL compatible serial data (TD and TDnot) into optical serial data.

The following versions are available:

1. AC/DC Transceiver

Tx is AC coupled. Differential 100 Ω load. Rx has standard PECL output and is DC coupled.

2. AC/AC TTL Transceiver

Tx and Rx are AC coupled. Tx has differential 100 Ω load. Signal Detect is TTL compatible.

3. DC/DC Transceiver

Standard PECL inputs and outputs Tx and Rx are DC coupled.

4. AC/AC PECL Transceiver

Tx and Rx are AC coupled. Tx has differential 100 Ω load. Signal Detect is PECL compatible.

The transmitter contains a laser driver circuit that drives the modulation and bias current of the laser diode. The currents are controlled by a power control circuit to guarantee constant output power of the laser over temperature and aging.

The power control uses the output of the monitor PIN diode (mechanically built into the laser coupling unit) as a controlling signal, to prevent the laser power from exceeding the operating limits.

Single fault condition is ensured by means of an integrated automatic shutdown circuit that disables the laser when it detects transmitter failures. A reset is only possible by turning the power off, and then on again.

The transceiver contains a supervisory circuit to control the power supply. This circuit generates an internal reset signal whenever the supply voltage drops below the reset threshold. It keeps the reset signal active for at least 140 milliseconds after the voltage has risen above the reset threshold. During this time the laser is inactive.

TECHNICAL DATA

The electro-optical characteristics described in the following tables are only valid for use under the recommended operating conditions.

Recommended Operating Conditions

Parameter	Symbol	Min.	Typ.	Max.	Units	
Ambient Temperature	T _{AMB}	0		70	°C	
Power Supply Voltage	3.3 V	V _{CC-V_{EE}}	3.1	3.3	3.5	V
	5 V		4.75	5	5.25	
Supply Current ⁽¹⁾	3.3 V	I _{CC}			230	mA
	5 V				270	
Transmitter						
Data Input High Voltage DC/DC	V _{IH-V_{CC}}	-1165		-880	mV	
Data Input Low Voltage DC/DC	V _{IL-V_{CC}}	-1810		-1475		
Data Input Differential Voltage ⁽²⁾ AC/DC, AC/AC TTL, AC/AC PECL	V _{DIFF}	250		1600		
Receiver						
Input Center Wavelength	λ _C	770		860	nm	

Notes

- For V_{CC-V_{EE}} (min., max.) 50% duty cycle. The supply current does not include the load drive current of the receiver output. Add. max. 45 mA for the three outputs. Load is 50 Ω to V_{CC}-2 V.
- Version C63: Low > 1.2 V; high < V_{CC}-0.8 V
Version C363: Low > 1.2 V; high < V_{CC}

Transmitter Electro-Optical Characteristics

Transmitter	Symbol	Min.	Typ.	Max.	Units
Launched Power (Average) ⁽¹⁾	P _O	-9.5		-4	dBm
Center Wavelength	λ _C	830	850	860	nm
Spectral Width (RMS)	σ _I			0.85	
Relative Intensity Noise	RIN			-117	dB/Hz
Extinction Ratio (Dynamic)	ER	9			dB
Reset Threshold ⁽²⁾	5 V	V _{TH}	3.5		V
	3.3 V		2.7		
Rise/Fall Time, 20%-80%	t _R , t _F			0.26	ns
Coupled Power Ratio	CPR	9			dB
Power Dissipation	5V	P _{Dist}	0.40	0.62	W
	3.3 V		0.23	0.39	

Notes

- Into multimode fiber, 62.5 μm or 50 μm diameter.
- Laser power is shut down if power supply is below V_{TH} and switched on if power supply is above V_{TH}.

Receiver Electro-Optical Characteristics

Receiver	Symbol	Min.	Typ.	Max.	Units
Sensitivity (Average Power) ⁽¹⁾	P _{IN}		-20	-17	dBm
Saturation (Average Power)	P _{SAT}			0	
Signal Detect Assert Level ⁽²⁾	P _{SDA}		-24	-18	
Signal Detect Deassert Level ⁽³⁾	P _{SDD}	-30	-27		dB
Signal Detect Hysteresis	P _{SDA} - P _{SDD}		3		
Signal Detect Assert Time	t _{ASS}			100	μs
Signal Detect Deassert Time	t _{DAS}			350	
Output Low Voltage ⁽⁴⁾	V _{OL-V_{CC}}	-1950		-1620	mV
Output High Voltage ⁽⁴⁾	V _{OH-V_{CC}}	-1100		-720	
Signal Detect Output Voltage AC/AC TTL ⁽⁵⁾	Low	V _{SDL}		0.5	V
	High	V _{SDH}	2.0		
Data Output Differential Voltage ⁽⁶⁾	V _{DIFF}	0.5	0.8	1.23	
Output Data Rise/Fall Time, 20%-80%	t _R , t _F			375	ps
Return Loss of Receiver	ARL	12			dB
Power Dissipation	5 V	P _{Disr}		0.63	W
	3.3 V			0.30	

Notes

- Minimum average optical power at which the BER is less than 1x10⁻¹² or lower. Measured with a 2⁷-1 NRZ PRBS and ER=9 dB. Output of multimode fiber 65 μm or 50 μm diameter.
- An increase in optical power above the specified level will cause the SIGNAL DETECT output to switch from a Low state to a High state.
- A decrease in optical power below the specified level will cause the SIGNAL DETECT to change from a High state to a Low state.
- DC/DC, AC/DC for data;
DC/DC, AC/DC, AC/AC PECL for SD
PECL compatible. Load is 50 Ω into V_{CC}-2 V for data, 500 Ω to V_{EE} for Signal Detect. Measured under DC conditions. For dynamic measurements a tolerance of 50 mV should be added. V_{CC} = 3.3 V/5 V. T_{AMB} = 25°C.
- Max. output current high: -0.4 mA (drive current)
low: +2.0 mA (sink current)
- AC/AC for data. Load 50 Ω to GND or 100 Ω differential. For dynamic measurement a tolerance of 50 mV should be added.

Pin Description

Pin Name	Level/Logic	Pin#	Description	
RxV _{EE}	Rx Ground	Power Supply	1	Negative power supply, normally ground
RD	Rx Output Data	PECL Output	2	Receiver output data
RDn			3	Inverted receiver output data
SD	Rx Signal Detect	PECL Output active high (TTL C53/353)	4	High level on this output shows there is an optical signal.
RxV _{CC}	Rx 3.3V/5V	Power Supply	5	Positive power supply, 3.3V/5V
TxV _{CC}	Tx 3.3V/5V		6	
TDn	Tx Input Data	PECL Input	7	Inverted transmitter input data
TD			8	Transmitter input data
TxV _{EE}	Tx Ground	Power Supply	9	Negative power supply, normally ground
Case	Support	Mech. Support	S1/2	Not connected

Regulatory Compliance

Feature	Standard	Comments
Electrostatic Discharge (ESD) to the Electrical Pins	MIL-STD 883C Method 3015.4	Class 1 (>1000 V)
Immunity: Electrostatic Discharge (ESD) to the Duplex SC Receptacle	EN 61000-4-2 IEC 61000-4-2	Discharges of ±15 kV with an air discharge probe on the receptacle cause no damage.
Immunity: Radio Frequency Electromagnetic Field	EN 61000-4-3 IEC 61000-4-3	With a field strength of 3 V/m rms, noise frequency ranges from 10 MHz to 1 GHz. No effect on transceiver performance between the specification limits.
Emission: Electromagnetic Interference EMI	FCC Class B EN 55022 Class B CISPR 22	Noise frequency range: 30 MHz to 6 GHz; Margins depend on PCB layout and chassis design

EYE SAFETY

This laser based single mode transceiver is a Class 1 product. It complies with IEC 60825-1 and FDA 21 CFR 1040.10 and 1040.11.

To meet laser safety requirements the transceiver shall be operated within the Absolute Maximum Ratings.

Caution

All adjustments have been made at the factory prior to shipment of the devices. No maintenance or alteration to the device is required.

Tampering with or modifying the performance of the device will result in voided product warranty.

Note

Failure to adhere to the above restrictions could result in a modification that is considered an act of "manufacturing", and will require, under law, recertification of the modified product with the U.S. Food and Drug Administration (ref. 21 CFR 1040.10 (i)).

Laser Data

Wavelength	850 nm
Total output power (as defined by IEC: 7 mm aperture at 1.4 cm distance)	< 675 µW
Total output power (as defined by FDA: 7 mm aperture at 20 cm distance)	< 70 µW
Beam divergence	12°

Required Labels

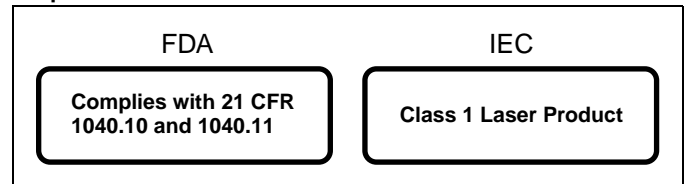

Laser Emission

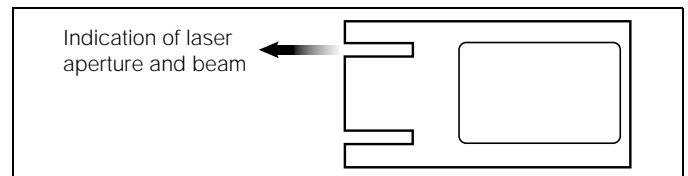

APPLICATION NOTE

Gigabit transceivers and matching circuits are high frequency components and shall be terminated as recommended in the application notes for proper EMI performance. Electromagnetic emission may be caused by these components.

To prevent emissions it is recommended that cutouts for the fiber connectors be designed as small as possible.

It is strongly recommended that the Tx plug and the Rx plug be separated with a bar that divides the duplex SC opening.

If shielded parts are employed, they should be in proper contact with the bezel (back plane).

Since the shield is galvanically isolated from signal ground it is strongly recommended to prevent any contact between shield and the circuitry i.e. even any ground connection on the pcb may be harmful to EMI performance.

In cases where EMI performance becomes critical it has proven to be helpful when using SC-plugs with less metal parts inside (as Infineon fibers).

APPLICATION NOTE

Multimode 850nm Gigabit Ethernet/Fibre Channel 1x9 Transceiver, DC/DC Version

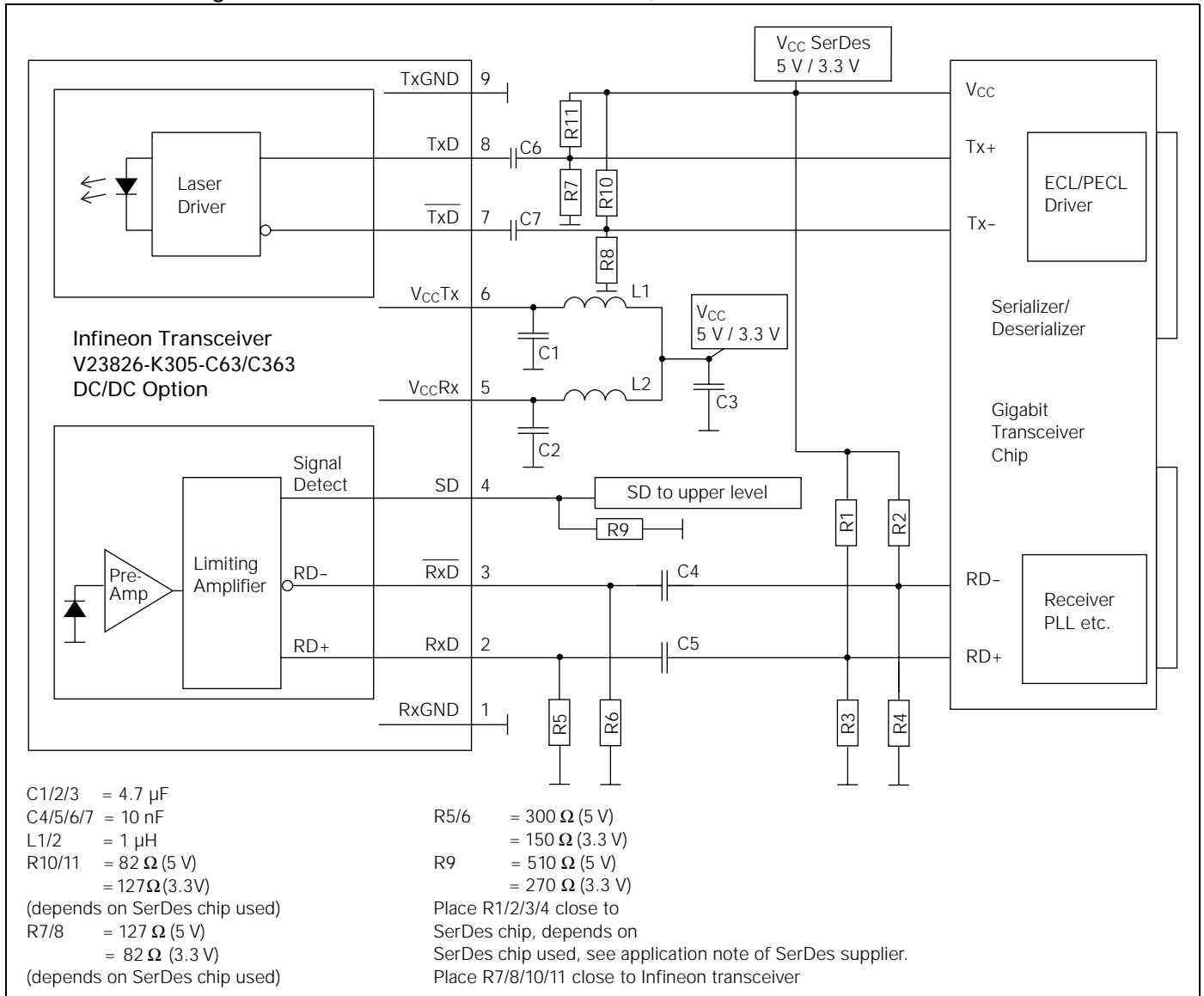

This Application Note assumes Fiber Optic Transceivers using 5 V power supply and SerDes Chips using 3.3 V power supply. It also assumes self biasing at the receiver data inputs (RD+/RD-) of the SerDes chip. Refer to the manufacturer data sheet for other applications. 3.3 V-Transceivers can be directly connected to SerDes-Chips using standard PECL Termination network.

Value of R1 may vary as long as proper 50 Ω termination to V_{EE} or 100 Ω differential is provided. The power supply filtering is required for good EMI performance. Use short tracks from the inductor L1/L2 to the module V_{CCRx}/V_{CCTx} .

The transceiver contains an automatic shutdown circuit. Reset is only possible if the power is turned off, and then on again. (V_{CCTx} switched below V_{TH}).

Application Board available on request.

APPLICATION NOTE

Multimode 850nm Gigabit Ethernet/Fibre Channel 1x9 Transceiver, AC/DC Version

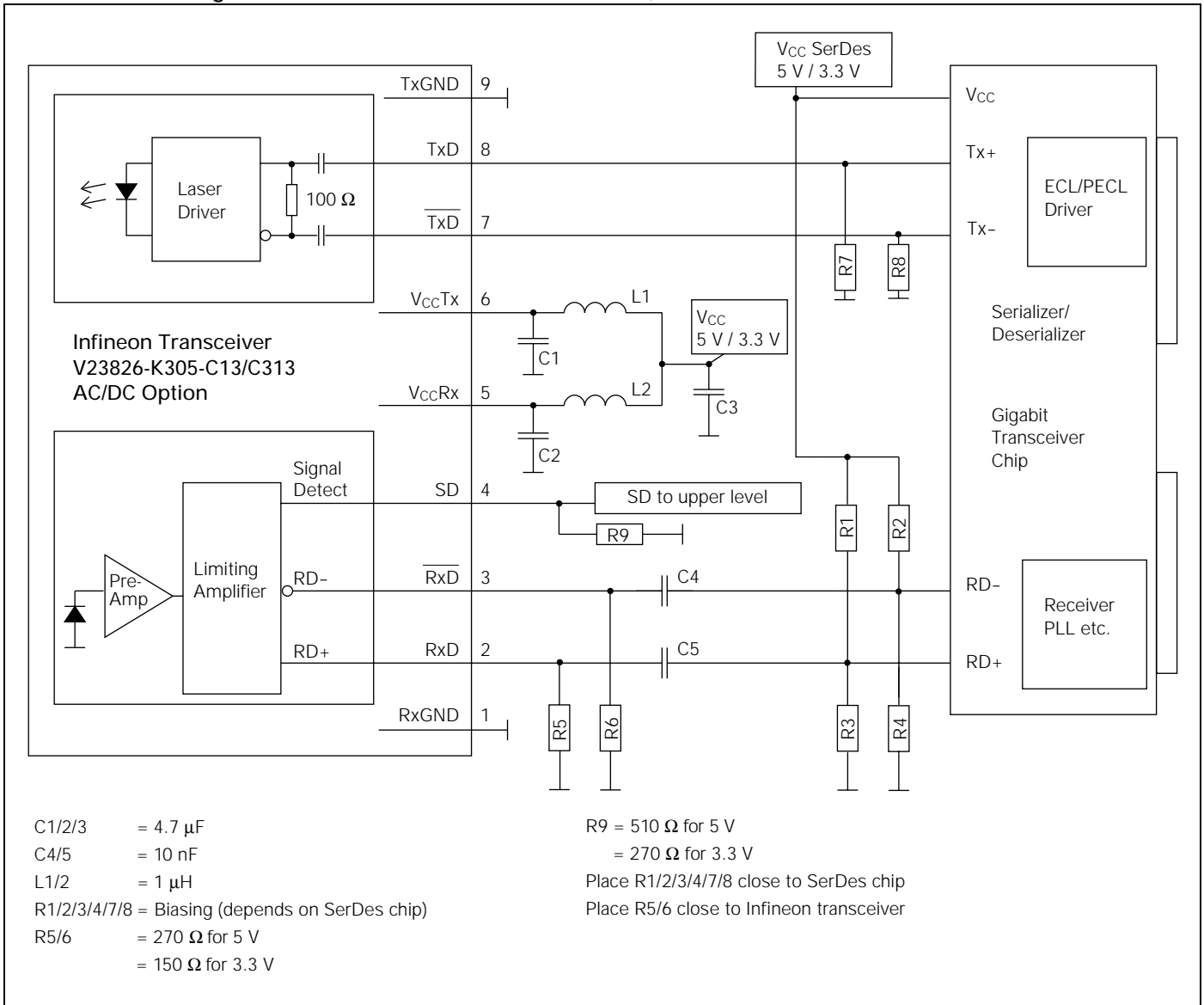

Values of R1/2/3/4 may vary as long as proper 50 Ω termination to V_{EE} or 100 Ω differential is provided. The power supply filtering is required for good EMI performance. Use short tracks from the inductor L1/L2 to the module V_{CCRx}/V_{CCTx} .

The transceiver contains an automatic shutdown circuit. Reset is only possible if the power is turned off, and then on again. (V_{CCTx} switched below V_{TH}).

Application Board available on request.

APPLICATION NOTE

Multimode 850nm Gigabit Ethernet/Fibre Channel 1x9 Transceiver, AC/AC TTL and AC/AC PECL Versions

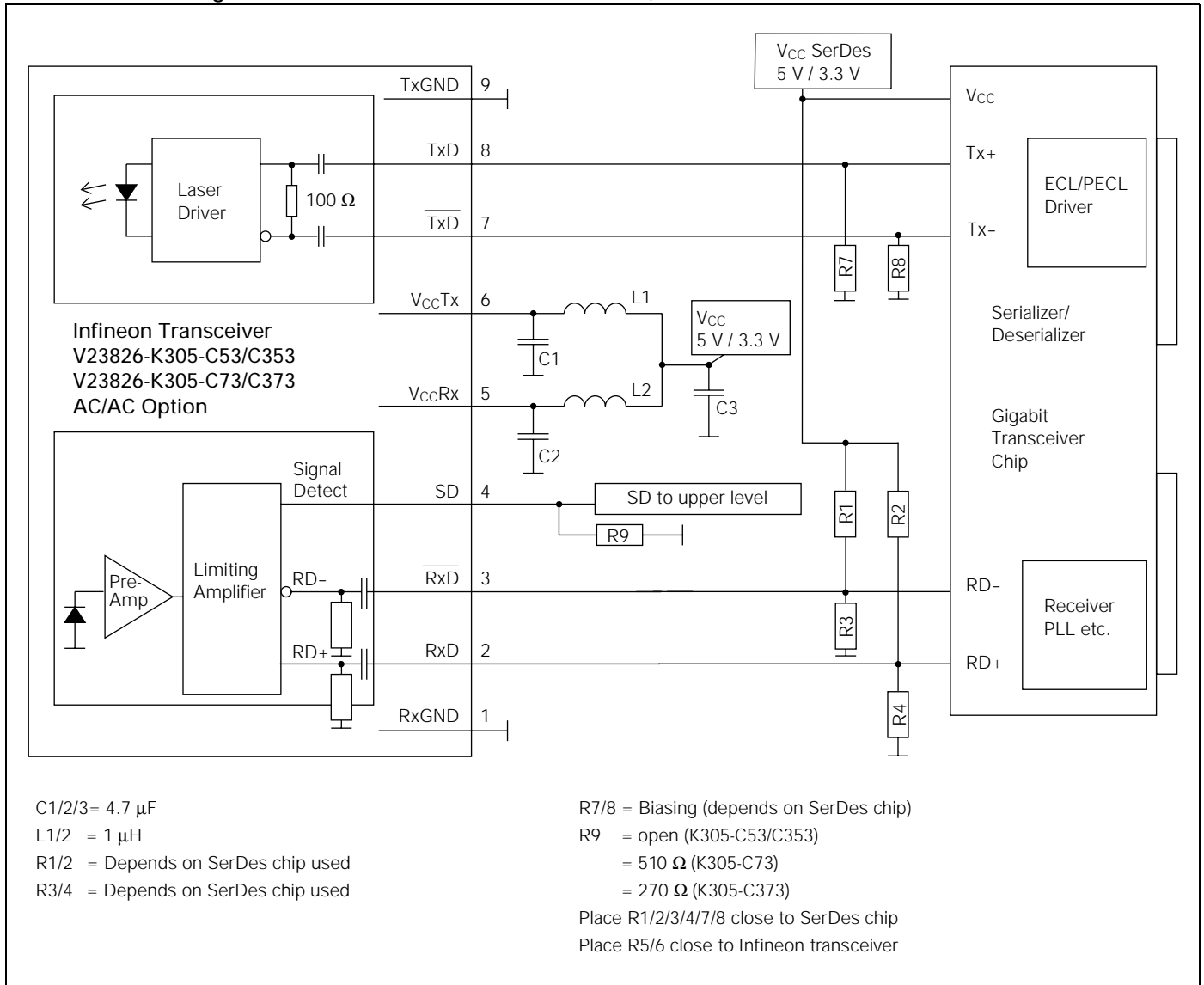

Values of R1/2/3/4 may vary as long as proper 50 Ω termination to V_{EE} or 100 Ω differential is provided. The power supply filtering is required for good EMI performance. Use short tracks from the inductor L1/L2 to the module $V_{CC\text{Rx}}/V_{CC\text{Tx}}$.

The transceiver contains an automatic shutdown circuit. Reset is only possible if the power is turned off, and then on again. ($V_{CC\text{Tx}}$ switched below V_{TH}).

Application Board available on request.

SHIELD OPTION

Shield with forward springs, -C3

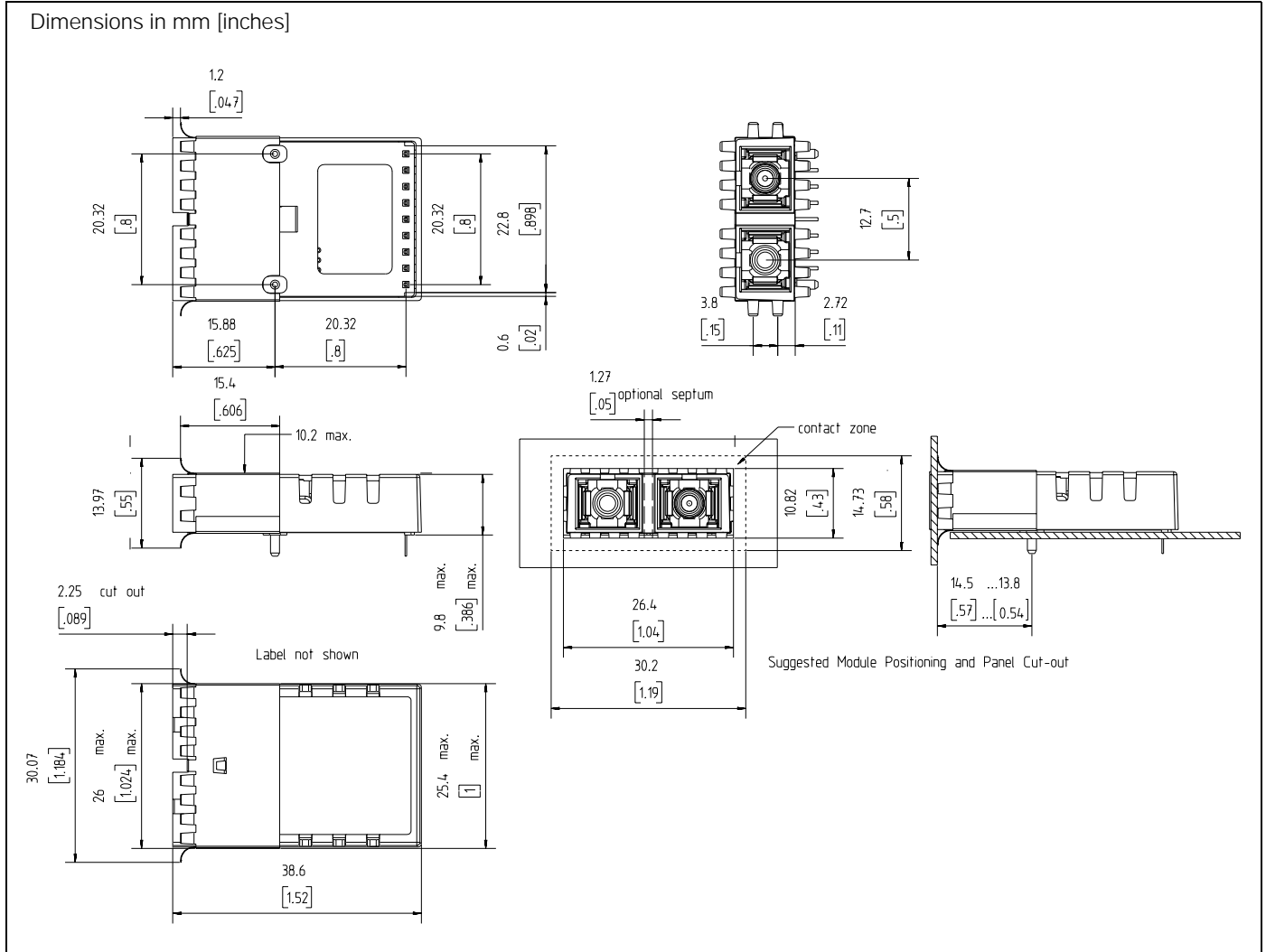

SHIELD OPTION

Shield with backward springs, -D3

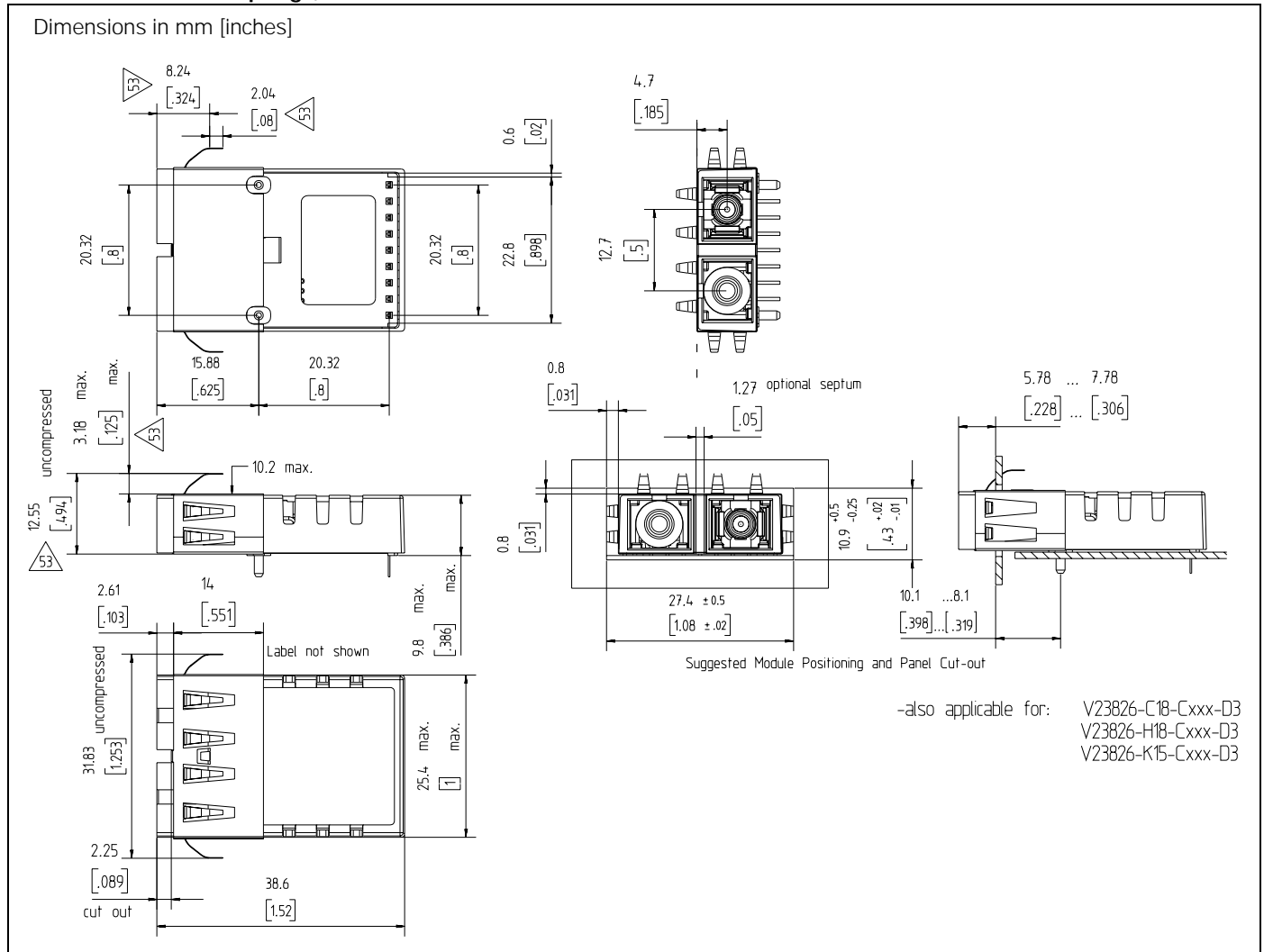

Published by Infineon Technologies AG

© Infineon Technologies AG 2000
All Rights Reserved

Attention please!

The information herein is given to describe certain components and shall not be considered as warranted characteristics.
Terms of delivery and rights to technical change reserved.
We hereby disclaim any and all warranties, including but not limited to warranties of non-infringement, regarding circuits, descriptions and charts stated herein.
Infineon Technologies is an approved CECC manufacturer.

Information

For further information on technology, delivery terms and conditions and prices please contact the Infineon Technologies offices or our Infineon Technologies Representatives worldwide - see our webpage at www.infineon.com/fiberoptics

Warnings

Due to technical requirements components may contain dangerous substances. For information on the types in question please contact your Infineon Technologies offices.
Infineon Technologies Components may only be used in life-support devices or systems with the express written approval of Infineon Technologies, if a failure of such components can reasonably be expected to cause the failure of that life-support device or system, or to affect the safety or effectiveness of that device or system. Life support devices or systems are intended to be implanted in the human body, or to support and/or maintain and sustain and/or protect human life. If they fail, it is reasonable to assume that the health of the user or other persons may be endangered.

Infineon Technologies AG • Fiber Optics • Wernerwerkdamm 16 • Berlin D-13623, Germany
Infineon Technologies, Inc. • Fiber Optics • 1730 North First Street • San Jose, CA 95112, USA
Infineon Technologies Japan K.K. • Fiber Optics • Takanawa Park Tower • 20-14, Higashi-Gotanda, 3-chome, Shinagawa-ku • Tokyo 141, Japan